

198" 6 CYL. DIESEL ENGINE

IDENTIFICATION CODING

ENGINE IDENTIFICATION

Engine codes not available at time of publication.

ENGINE REMOVAL

Engine removal procedure not available at time of publication.

CYLINDER HEAD & MANIFOLDS

INTAKE & EXHAUST MANIFOLD

Removal — Disconnect air cleaner brace at intake manifold, loosen air cleaner lock bolt and remove air cleaner. Remove hose from rocker arm cover to intake manifold, do not lose the copper gaskets. Remove nuts securing intake and exhaust manifolds to cylinder head. Remove manifolds and gaskets from cylinder head.

Installation — To install intake and exhaust manifolds reverse removal procedure and tighten all retaining nuts evenly from center out.

CYLINDER HEAD

Removal — 1) Disconnect and plug fuel lines to fuel filter. Disconnect high pressure fuel lines from injection pump and fuel injectors, cap fuel injectors and delivery valves on fuel injection pump.

2) Remove rocker arm cover. Remove rocker arm shaft bolts and lift rocker arm shaft assembly off head. Remove push rods and fuel return spill tube. Remove fuel injectors from cylinder head. Remove head bolts as shown in Fig. 1. Lift cylinder head from block with a hoist. Remove head gasket and "O" rings from water and oil passages.

NOTE — Care should be taken to keep the pre-combustion chambers from falling out at this time. If they do fall out, replace them in their original positions.

Installation — 1) Install cylinder head gasket on block with the largest stainless steel rings facing up. Install "O" rings in water and oil passages.

2) Place cylinder head on block. Coat both main and sub-cylinder head bolts with engine oil. Tighten bolts in sequence shown in Fig. 2 in two steps. In first step, tighten main bolts to 43 ft. lbs. (6 kgm) and sub-bolts to 22 ft. lbs. (3 kgm). In second and final step tighten main bolts to 94 ft. lbs. (13 kgm) and sub-bolts to 36 ft. lbs. (5 kgm).

3) Install push rods with round end down. Install rocker arm shaft assembly and tighten. Install fuel injectors in cylinder head. Replace rocker arm cover, high pressure fuel lines and fuel lines to fuel filter.

NOTE — Turn push rods while applying downward pressure to make sure they are seated in valve lifters.

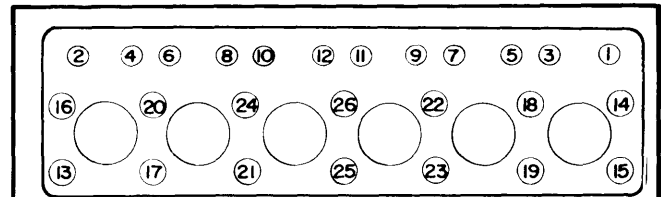

Fig. 1 Cylinder Head Bolt Loosening Sequence

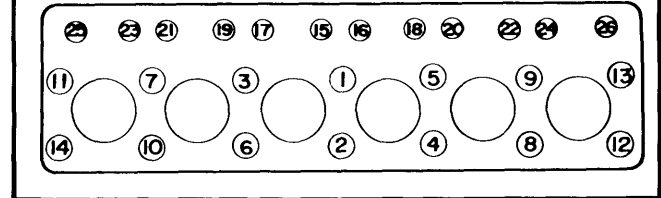

Fig. 2 Cylinder Head Bolt Tightening Sequence

VALVES

VALVE ARRANGEMENT

E-I-I-E-E-I-I-E-E-I-I-E (front to rear).

VALVE GUIDE SERVICE

Intake and exhaust valve guides are integral with the cylinder head. Oversize valves are available in two sizes; .323" (8.2 mm) or .331" (8.4 mm). When servicing valve guides, ream intake valve guide .0006-.0012" (.015-.03 mm) larger than oversize valve. Ream exhaust valve guide .0016-.0022" (.04-.055 mm) larger than oversize valve.

VALVE STEM OIL SEALS

Each valve stem is fitted with an umbrella type oil seal below valve stem retainer.

VALVE SPRINGS

Removal — With cylinder head and rocker arm assembly removed, compress valve spring and remove keepers, retainer and spring. Remove oil seal from valve by removing retaining clip.

Installation — Reverse removal procedure to install valve springs.

ROCKER ARM ASSEMBLY

Rocker arm assembly consists of a shaft, rocker arms, supports and spacer springs. When disassembling rocker assembly, heat in water at 158°F (70°C) to ease in removal of supports. Inspect rocker arm shaft and components for excessive wear or damage and replace as necessary.

198" 6 CYL. DIESEL ENGINE (Cont.)

VALVE CLEARANCE ADJUSTMENT

To adjust valve clearance, place number one cylinder at TDC then adjust valves specified in chart. With those valves adjusted, place No. 6 cylinder at TDC and adjust valves specified in chart.

NOTE — All valves are numbered front to rear and all valves are adjusted to a clearance of .014" (.35 mm).

Cylinder No. at TDC	Valves to Adjust
1	1-2-4-6-8-10
6	3-5-7-9-11-12

PISTONS, PINS & RINGS

OIL PAN

Oil pan removal procedure not available at time of publication.

PISTON & ROD ASSEMBLY

Removal — With cylinder head and oil pan removed, remove oil pump. Remove any ridge and/or deposits from cylinder liners before attempting to remove piston and rod assembly. Turn crankshaft until piston to be removed is at bottom of its travel. Remove connecting rod nuts and rod cap with bearing. Ensure that all connecting rods, caps and bearings are marked so that they can be installed in their original positions. Carefully push piston and rod assembly out top of cylinder.

Installation — Before installing piston and rod assembly, space piston ring gaps 180° from previous ring installed, but not above piston pin ends. Wipe cylinder walls clean with a cloth and coat with oil. Position connecting rod bearings in rod and cap. Lubricate crankshaft journals and bearings. Oil piston rings and piston, then compress rings with a suitable ring compressor. Install piston from top of cylinder block with cylinder number, stamped on connecting rod big end, facing exhaust manifold side of engine block (combustion chamber in piston head faces injection pump side of engine block). Push piston into cylinder, carefully aligning bearing on journal. Install rod cap, making sure number on cap matches number on rod. Install rod cap, with bearing, rod cap nuts and tighten.

CONNECTING ROD END PLAY

Install connecting rod, with bearings, to the crankshaft rod journal that it was removed from. Torque bolts to specifications then measure clearance between side surface of rod and web of crankshaft. Clearance should be .004-.008" (.1-2 mm), if clearance is not to specifications replace connecting rod.

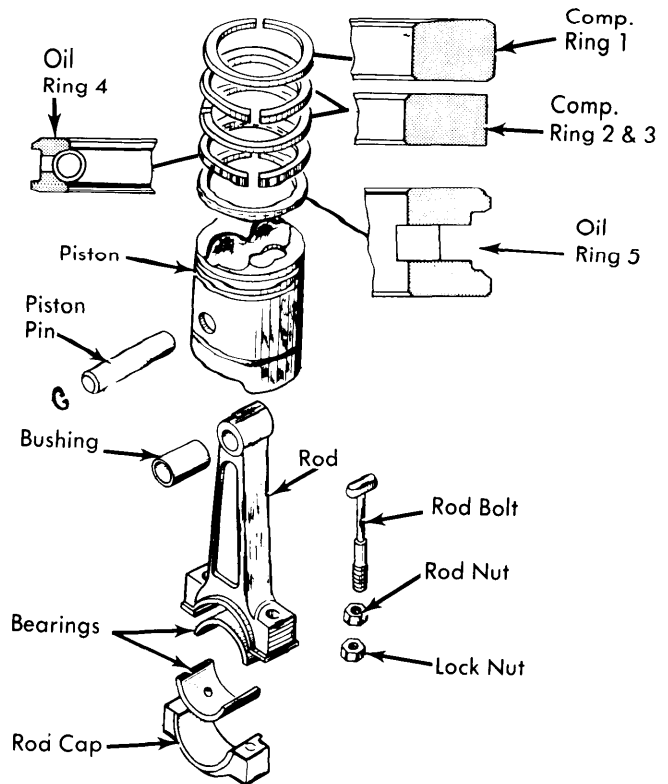

Fig. 3 Exploded View of Piston & Rod Assembly with Piston Ring Placement

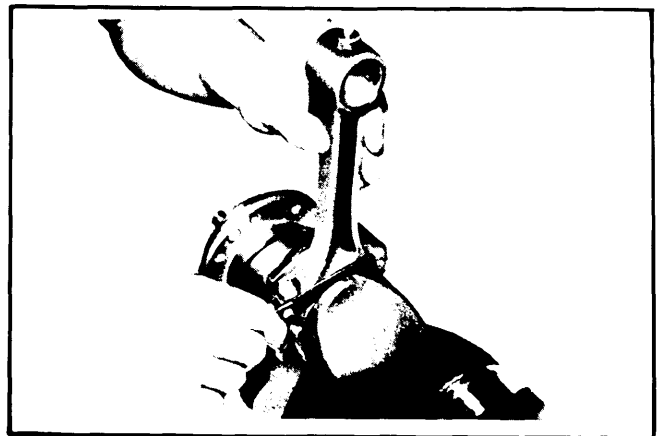

Fig. 4 Measuring Connecting Rod End Play

FITTING PISTONS

Check piston to cylinder bore clearance by measuring cylinder bore and then piston diameter. Measure piston diameter at a point 2" (50 mm) from top of piston and 90° from piston pin. If difference between cylinder bore and piston diameter is more than .012" (.3 mm) replace pistons or cylinder liners.

198" 6 CYL. DIESEL ENGINE (Cont.)

PISTON PINS

Removal — With piston and rod assembly removed, remove piston rings and piston pin circlips. Remove piston pin and check clearance of pin in piston and connecting rod.

Installation — Assemble pistons to corresponding connecting rod. To ensure correct assembly of piston to rod, fit piston so that combustion chamber is opposite cylinder number stamped on connecting rod. Install piston pins and fit circlips at each end to retain in piston.

MAIN & CONNECTING ROD BEARINGS

Connecting Rod Bearings — With oil pan removed, rotate crankshaft until connecting rod to which bearings are to be replaced is at bottom dead center. Remove rod cap and push piston and rod assembly part way up cylinder. Remove bearings from rod and cap, then clean crankshaft journal and connecting rod and rod cap. Install new bearings and check clearance using the Plastigage method. Clearance should be .001-.004" (.035-.095 mm). If clearance is not correct, remove crankshaft and refinish connecting rod journals; then install undersize bearings. Bearings are available in .010", .020", .030", and .040" (.25, .50, .75, and 1 mm) undersizes.

Main Bearings — Remove oil pan and oil pump. Remove main bearing cap. Replace one bearing at a time, leaving other bearing caps tight. To remove upper bearing, rotate crankshaft while pushing on bearing (opposite tang side). To install upper bearing, insert bearing in reverse of removal and rotate crankshaft in opposite direction of removal, until bearing is seated. Check clearance with Plastigage method. If clearance is not to specifications, remove crankshaft, refinish and insert undersize bearings. Bearings are available in .010", .020", .030", and .040" (.25, .50, .75, and 1 mm) undersizes.

THRUST BEARING ALIGNMENT

Crankshaft thrust and end play are controlled by thrust washers located on both sides of No. 3 main bearing. If end play is excessive, more than .0024-.0095" (.06-.24 mm), add oversize washers. Oversize washers are available in .008" and .016" (.2 and .4 mm). Standard thrust washer is .093" (2.35 mm) thick.

REAR MAIN BEARING OIL SEAL

To install, apply a suitable sealer to completely seal housing groove in cylinder block and rear main bearing cap and immediately install seal. Trim ends of seal so that they protrude .02" (.5 mm) above joint face of rear main bearing.

CAMSHAFT**TIMING GEARS & CAMSHAFT**

Removal — Remove crankshaft pulley, water pump and injector pump timer cover. Remove oil seal and timing gear case. Remove injector pump timer and oil pump drive gear. Remove oil jet and camshaft gear with camshaft. Remove gears from camshaft.

Installation — To install, reverse the removal procedure. Be sure to align marks on camshaft gear with marks on crankshaft and injection pump timer gears. Align the "X" mark on camshaft gear with the "X" mark on crankshaft gear. Align the "Y" mark on camshaft gear with the "Y" mark on the injection pump timer gear. Install oil jet so that holes are pointing to camshaft gears and to crankshaft gear.

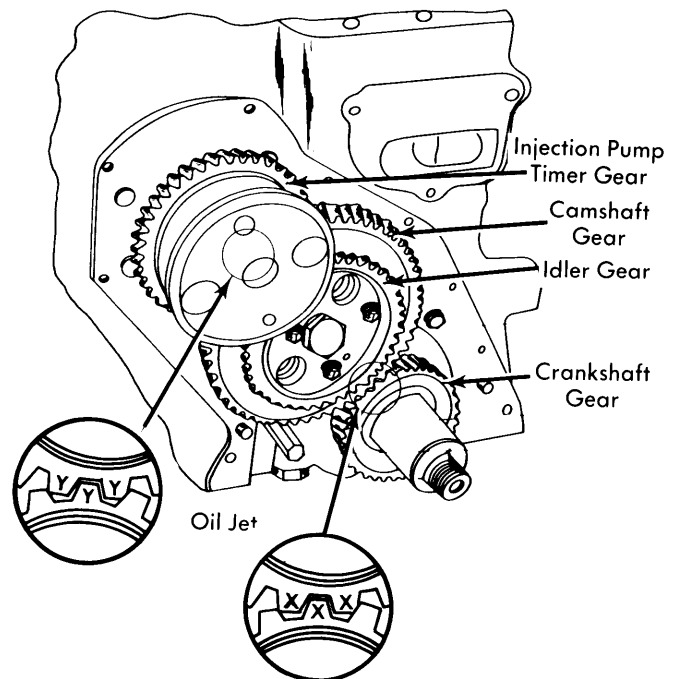

Fig. 5 Timing Gear Installation Alignment

ENGINE OILING**ENGINE OILING SYSTEM**

Oil pump is driven by a gear on camshaft and provides full pressure to all camshaft, crankshaft and connecting rod bearings. Drillings in camshaft rear journal control oil feed to rocker shaft. Oil from rocker arms drain through push rod drillings and lubricate tappets. Cylinder bores and piston pins are lubricated by splash oil from connecting rod journals.

Crankcase Capacity — 198" engine uses 8 qts. (7.5 ltr.).

Oil Filter — Full-flow oil filter with a replaceable paper filter element.

Normal Oil Pressure — Oil pressure at idle should be a minimum of 14.22 psi (10 kg/cm²). At 2000 RPM, oil pressure should be a minimum of 50 psi (3.5 kg/cm²).

198" 6 CYL. DIESEL ENGINE (Cont.)

Pressure Regulator Valve — The 198" engine uses two regulator valves, one located in oil pump (relief valve) and one located in filter assembly (regulator valve). The relief valve controls maximum oil pressure at 107-114 psi (7.5-8 kg/cm²). The regulator valve controls oil pressure in the filter element at 44-50 psi (3.1-3.5 kg/cm²).

OIL PUMP

Disassembly — With oil pump removed, separate pickup screen from pump cover. Remove bolts securing pump cover to pump and separate. Remove driven gear from pump. Remove drive gear using a puller, then press driven gear shaft from pump housing. Remove cotter pin from relief valve and remove relief valve spring and piston.

NOTE — Relief valve is under spring pressure, be careful when removing cotter pin.

Assembly — Coat all parts with oil then assemble pump in reverse order of disassembly noting the following: Place beveled side of gears toward the oil pump body. Check clearances after gears have been assembled. Then rotate pump drive shaft by hand and ensure that it operates smoothly.

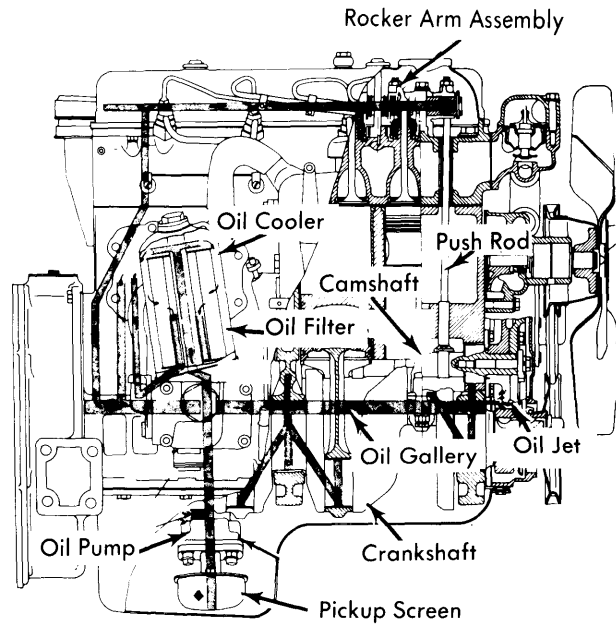

Fig. 7 Diesel Oiling System

ENGINE SPECIFICATIONS

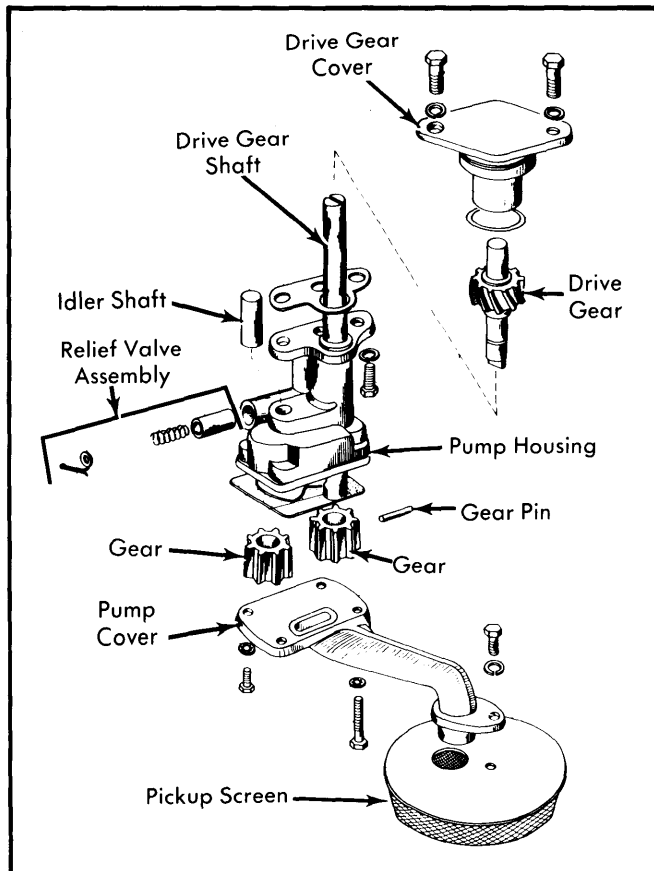

Fig. 6 Exploded View of Oil Pump Assembly

TIGHTENING SPECIFICATIONS

Application	Ft. Lbs. (kgm)
Cylinder Head Bolts	
Main Bolts	94 (13)
Sub Bolts	36 (5)
Connecting Rod Bolts	36-40 (5-5.5)
Main Bearing Cap Bolts	109-115 (15-16)
Camshaft	
Gear Mounting Bolt	33-36 (4.5-5)
Locating Plate Bolt	3-4 (.4-.6)
Crankshaft Pulley Bolt	217-239 (30-33)
Flywheel	
Mounting Bolts	33-36 (4.5-5)
Housing Bolts	47-54 (6.5-7.5)
Rocker Arm Shaft Bolts	15-18 (2-2.5)
Injection Nozzle	
Holder	51-65 (7-9)
Overflow Nut	29-36 (4-5)
Injection Pump	
Timer Nut	51-58 (7-8)
Mounting Bolts	15-18 (2-2.5)
Intake & Exhaust Manifold Bolts	11-13 (1.5-1.8)
Timer Cover Bolts	3-4 (.4-.6)
Timing Gear Case Bolts	
8mm	7-9 (1-1.3)
6mm	3-4 (.4-.6)
Oil Pan Bolts	3-4 (.4-.6)
Water Pump Bolts	
10mm	15-18 (2-2.5)
8mm	7-9 (1-1.3)

IHC 6 Engines

198" 6 CYL. DIESEL ENGINE (Cont.)

ENGINE SPECIFICATIONS (Cont.)

GENERAL SPECIFICATIONS										
Year	Displ.		Carburetor	HP at RPM	Torque (Ft. Lbs. at RPM)	Compr. Ratio	Bore		Stroke	
	cu. ins.	cc					in.	mm	in.	mm
1978	198	3246	Fuel Inj.	73@3200	133@1600	22:1	3.27	83	3.94	100

VALVES							
Engine & Valve	Head Diam. In. (mm)	Face Angle	Seat Angle	Seat Width In. (mm)	Stem Diameter In. (mm)	Stem Clearance In. (mm)	Valve Lift In. (mm)
198" Int.	1.516" (38.5 mm)	45.5°	45°	.032-.055" (.8-1.4 mm)	.315" (8 mm)	.0006-.0018" (.015-.045 mm)	.248" (6.3 mm)
Exh.	1.28" (32.5 mm)	45.5°	45°	.032-.055" (.8-1.4 mm)	.315" (8 mm)	.0016-.0028" (.04-.07 mm)	.248" (6.3 mm)

PISTONS, PINS, RINGS						
Engine	PISTONS Clearance	PINS		RINGS		
		Piston Fit	Rod Fit	Rings	End Gap	Side Clearance
198"	.005-.007" (.12-.17 mm)	⊙	.001-.002" (.025-.047 mm)	Comp. 1	.012-.02" (.3-.5 mm)	.0024-.0039" (.06-.1 mm)
				Comp. 2&3	.012-.02" (.3-.5 mm)	.0016-.0032" (.04-.08 mm)
				Oil 4 & 5	.012-.02" (.3-.5 mm)	.001-.0024" (.02-.06 mm)

⊙ — Clearance should be .0001 loose to .0001 tight.

CRANKSHAFT MAIN & CONNECTING ROD BEARINGS							
Engine	MAIN BEARINGS				CONNECTING ROD BEARINGS		
	Journal Diam.	Clearance	Thrust Bearing	Crankshaft End Play	Journal Diam.	Clearance	Side Play
198"	2.795" (71 mm)	.001-.004" (.035-.095 mm)	No. 3	.002-.009" (.06-.024 mm)	2.087" (53 mm)	.001-.004" (.035-.09 mm)	.004-.008" (.1-.2 mm)

VALVE SPRINGS			
Engine	Free Length	PRESSURE (LBS.)	
		Valve Closed	Valve Open
198"	1.93" (49 mm)

CAMSHAFT			
Engine	Journal Diam.	Clearance	Lobe Lift
198"	Front 1.79" (45.45 mm)	.001-.004" (.023-.108 mm)	.248" (6.3 mm)
	2 & 3 1.73" (43.91 mm)	.002-.005" (.04-.125 mm)	
	Rear 1.62" (41.23 mm)	.001-.004" (.029-.114 mm)	