

## 243" 6 CYLINDER DIESEL ENGINE

## IDENTIFICATION CODING

## ENGINE IDENTIFICATION

Engine identification number is stamped on left side of block below No. 6 cylinder. First number indicates year (8).

## ENGINE REMOVAL

See *Engine Removal at end of ENGINE Section.*

## CYLINDER HEAD &amp; MANIFOLDS

## MANIFOLD ASSEMBLY

**Removal** – 1) Drain cooling system and remove air cleaner. Disconnect fuel filter hose at transfer and injection pump. Drain filter and remove from back of air intake manifold.

2) Disconnect No. 3 & 6 fuel injection lines from injection pump. Disconnect all lines, wires or hoses on air intake manifold. Remove manifold.

**Installation** – 1) Position intake manifold and spray shield on head. Connect No. 3 & 6 fuel injection lines to injection pump. Install filter in back of air intake manifold. Connect all lines, wires and hoses on manifold. Install nuts securing manifold and air cleaner brackets. Tighten all nuts firmly.

## CYLINDER HEAD

**Removal** – 1) Drain cooling system and remove air cleaner. Disconnect all lines, hoses and wiring to head and intake manifold. Disconnect No. 3 & 6 fuel injection lines. Remove thermostat housing and radiator hose from water manifold. Disconnect fuel line bracket from head and position out of way.

2) Remove three exhaust manifold bridges. Remove water manifold and raise vehicle to disconnect exhaust pipe from exhaust manifold. Lower vehicle and remove heat shield, exhaust manifold and gasket.

3) Disconnect alternator bracket and engine lifting fixture and position to one side. Remove cylinder head bolts in sequence shown in Fig. 1.

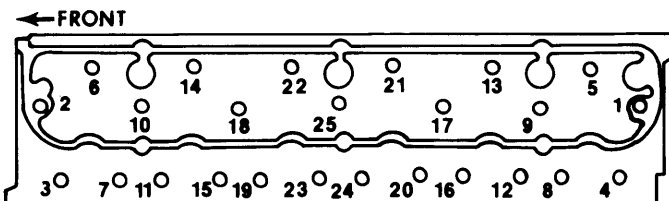

Fig. 1 Cylinder Head Bolt Removal

4) Remove injector tubes, holders and injectors. Mark push rods for installation in the original location. Remove glow plug buss bar. Remove cylinder head.

**Inspection** – Check head and combustion chambers for cracks, damage and evidence of water leakage. Check jets for cracks or melting.

**Installation** – 1) Install glow plug and buss bar and make sure connections are tight. Install injectors, tubes and holders in cylinder heads. Tighten nozzle holders to specifications. Use suitable sealer and install cylinder head over dowels.

2) Install head bolts and tighten in sequence as shown in Fig. 2. Install push rods and rocker arm assembly.

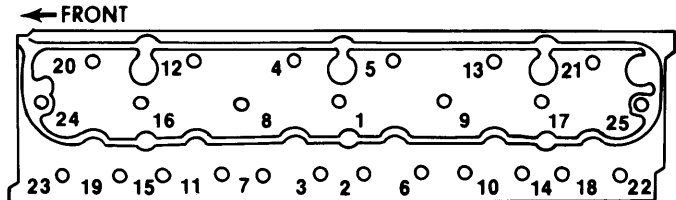

Fig. 2 Cylinder Head Tightening Sequence

**NOTE** – Rocker arm bracket bolts are cylinder head bolts.

3) Install alternator and engine lift brackets. Install exhaust manifolds and shield assembly. Raise vehicle and connect exhaust pipe to manifold. Lower vehicle and install three manifold bridges. Install thermostat housing and connect all lines, hoses and wiring.

4) Connect No. 3 & 6 fuel injection lines. Install fuel filter on back of air manifold and install air cleaner. Fill cooling system and test.

## VALVES

## VALVE ARRANGEMENT

E-I-E-I-E-I-E-I-E-I-E-I

## VALVE GUIDE SERVICING

**Wear Check** – Remove valve springs and install sleeve tool C-3973 (or equivalent), on valve stem as shown in Fig. 3. Install valve in cylinder head valve guide. Attach dial indicator to head and set at right angles to valve stem. Measure stem-to-guide clearance as shown in Fig. 4. Intake clearance should not exceed .006" (0.15 mm). If clearance exceeds limits, replace both valve and valve guide. If exhaust valve-to-guide clearance exceeds .008" (0.20 mm), replace valve and guide.

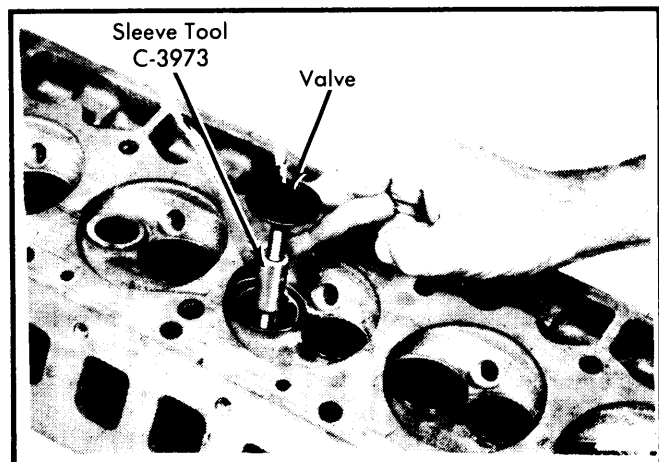
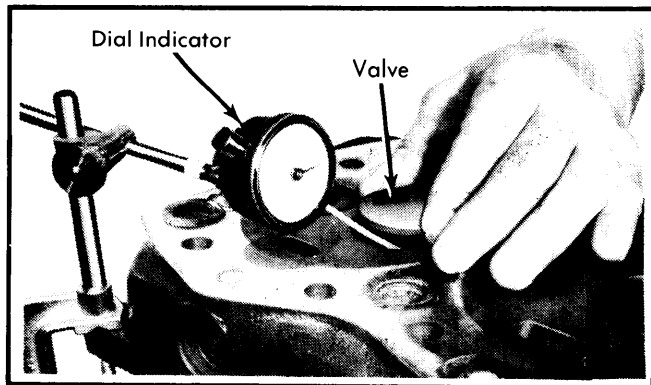

Fig. 3 Installation of Sleeve Tool C-3973

## 243" 6 CYLINDER DIESEL ENGINE (Cont.)



**Fig. 4** Measuring Valve Stem to Guide Clearance

### VALVE GUIDE REPLACEMENT

**Removal & Installation** — Use valve guide removal tool 31691-10500 to press old guide out of cylinder head. Press new valve guide into place using valve guide installing tool 31691-10600. Measure valve guide length from bottom of head seat to top of guide. Length must be between 0.7583-0.791" (19.7-20.3 mm).

**NOTE** — When valves are removed or replaced, new oil seal must be installed.

### VALVE SPRINGS

**Removal** — With cylinder head removed, use valve spring compression tool C-3422A (or equivalent), to compress valve spring. Remove retaining locks, spring retainers, inner and outer springs and oil seals.

**Inspection** — 1) Valve springs must be tested whenever they are removed from cylinder head. Use spring tester C-647 and a torque wrench to test springs. Follow manufacturers instructions for spring test. See Fig. 5.

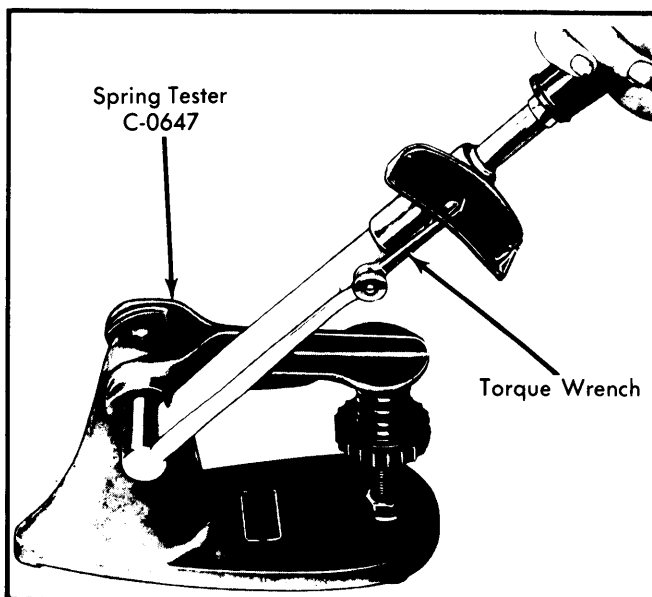

**Fig. 5** Testing Valve Spring

2) Each spring must be tested for squareness by using mechanics square and flat surface. See Fig. 6. Test each spring from both ends. Spring should be square within 1/16".

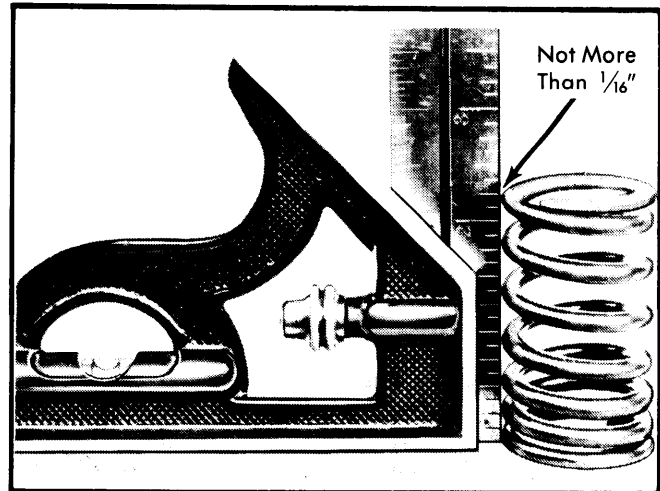

**Fig. 6** Valve Spring Squareness Test

**Installation** — Lubricate valve stems with engine oil and install in cylinder head. Install new oil seals, inner and outer springs and retainers. Compress springs and install upper retainers and locks.

### VALVE SPRING INSTALLED HEIGHT

Measure installed height from bottom surface of spring retainer to bottom of cylinder head spring seat. Install appropriate spacer in head counterbore to bring height back to specifications if necessary. Inner spring height is 1.533" (39 mm). Outer spring height is 1.769" (45 mm).

### ROCKER ARM ASSEMBLY

Rocker arms are mounted on a hard chrome plated rocker shaft in pairs with springs and spacers to keep them apart. Dimensions of the intake and exhaust rocker arm differ because of the difference in distance from rocker shaft centerline to intake and exhaust valve push rods. See Fig. 7. Rocker arm and shaft assembly mounts to cylinder head through seven cast iron brackets secured by cylinder head bolts. If rocker arms were removed, be sure they are installed in original location. Rocker arms have replaceable pressed bushings. If rocker arm bushing to shaft clearance exceeds .0003" (0.07 mm), replace bushing.

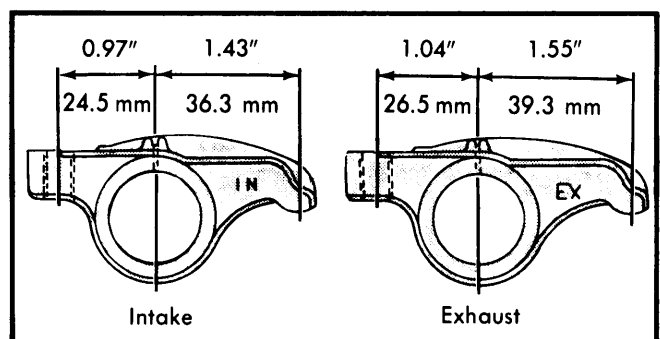

**Fig. 7** Rocker Arms

## 243" 6 CYLINDER DIESEL ENGINE (Cont.)

## MECHANICAL VALVE LIFTERS

Lifters are tubular, hollow cast iron with chill hardened bottom surface which contacts cam lobes. Push rod end is spherical to accommodate rod. Lifter is designed to rotate during operation to reduce surface wear. Clearance between bore and lifter must not exceed 0.004" (0.1 mm).

## VALVE CLEARANCE ADJUSTMENT

Adjust valve at TDC of compression stroke. Clearance is 0.012" (0.3 mm) for each cylinder. See Fig. 8.

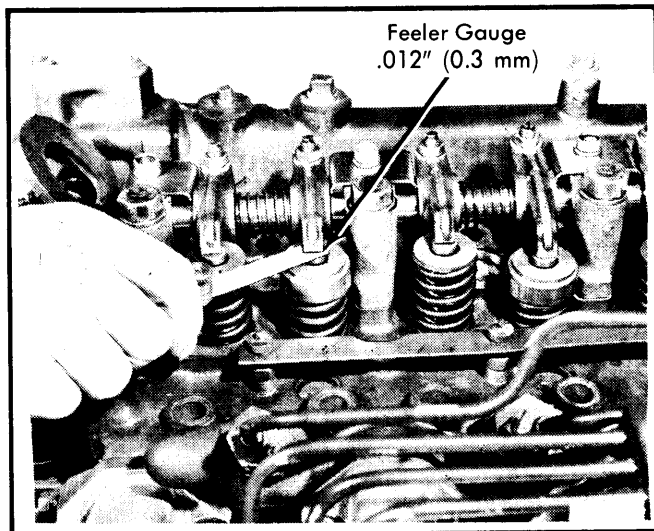

Fig. 8 Valve Adjustment

## OIL PAN

See Oil Pan Removal at end of ENGINE Section.

## PISTONS, PINS &amp; RINGS

## PISTON &amp; ROD ASSEMBLY

**NOTE** — Following procedure is with cylinder head and oil pan removed.

**Removal** — 1) Turn crankshaft until piston is at bottom of stroke. Cover top of piston with cloth to collect metal cuttings. With ridge reamer, remove any deposits or ridge from top of cylinder sleeve. Remove connecting rod cap nuts, cap and install bolt cover to protect cylinder sleeve.

2) With hardwood block, drive piston and rod assembly out top of block. Be sure rod and cap are marked for installation in same location.

**NOTE** — Pistons are marked with weight symbol on head. Replacement pistons must be within same weight range to maintain engine balance.

**Installation** — 1) Oil piston rings, piston and sleeve wall lightly with engine oil. Install piston in original location making sure rings are positioned as shown in Fig. 9.

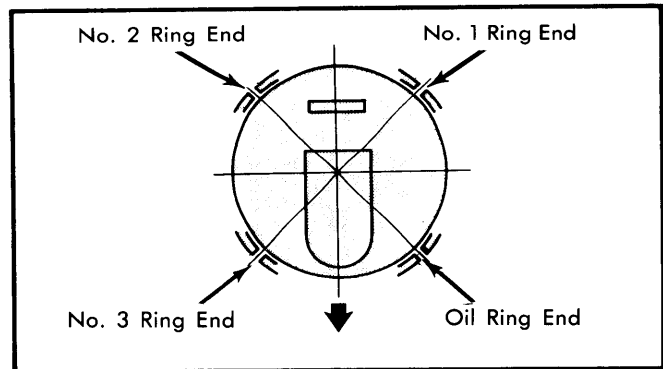

Fig. 9 Piston Ring Gap

2) Install piston so that combustion chamber side of piston is opposite camshaft side of engine. (Chamber to left side of engine). Tap piston down with hammer handle while guiding connecting rod into position over rod journal. Repeat procedure for each piston removed.

## FITTING PISTONS

1) Measure inside diameter of cylinder sleeve in three locations, top, middle and bottom. Make measurements parallel and at right angle to crankshaft centerline at each location.

2) Push ring into sleeve bore by inverting a piston to insure ring is square in bore. Measure by inserting feeler gauge in ring gap. Gap should be between 0.012-0.020" (0.30-0.50 mm).

3) Install rings in piston in proper order and measure side clearance as shown in Fig. 10. Hold rings flush with piston surface with straightedge. Insert feeler gauge. Clearances are as follows:

- No. 1. .0011-.002" (.028-.059 mm)
- No. 2, 3 & 4. .00098-.0023" (.025-.060 mm)

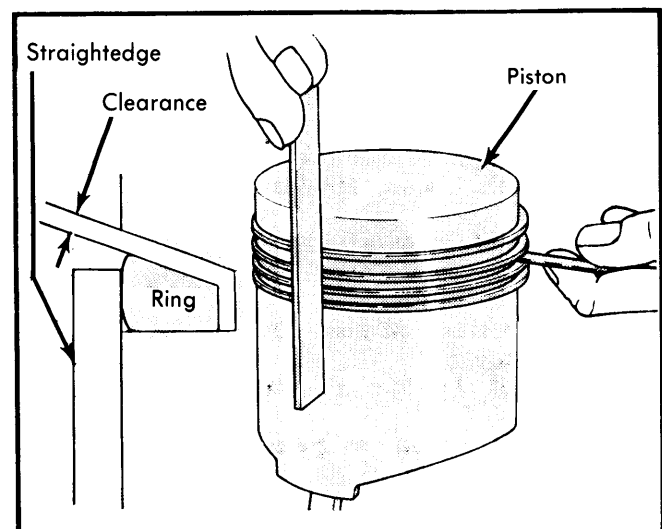

Fig. 10 Measuring Piston Groove

4) Install rings with "UP" side toward top of piston. On expander oil ring, install a piece of Teflon tape between piston and expander over gap area. See Fig. 11.

## 243" 6 CYLINDER DIESEL ENGINE (Cont.)

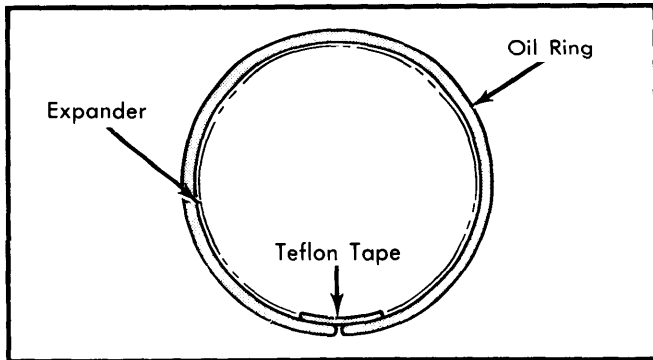

Fig. 11 Oil Ring Teflon Location

### PISTON PINS

**Removal** — Remove snap rings and use piston pin removal tool C-3724 (or equivalent), to press pin from piston. Measure inside diameter of pin bore and outside diameter of pin. Pin-to-bore clearance should be between interference and .0006" (.016 mm).

**Installation** — Assemble piston to connecting rod with combustion chamber side of piston on weight stamp side of rod. Pin should be press fit into piston and rod. Install snap rings with open side toward bottom of piston skirt.

### CRANKSHAFT & ROD BEARINGS

#### MAIN & CONNECTING ROD BEARINGS

**NOTE** — The following procedure is performed with oil pan removed.

**Connecting Rod Bearings** — 1) Plastigage method may be used to check bearing clearance in place of shim stock method. Loosen bearing cap and install a piece of 1/2 by 3/4" shim stock, .001" thick between lower bearing insert and connecting rod journal.

2) Tighten bearing cap to 69 ft. lbs. (9.54 Mkg). Rotate crankshaft 1/4 turn in each direction. If clearance is satisfactory, a slight drag will be felt. Remove shim stock and tighten bearing caps to specifications.

3) Connecting rods are classified by weight range. When selecting replacement rods, they must be in same weight range as original.

**Main Bearings** — 1) Use shim stock or Plastigage method to check main bearing clearance one at a time. Undersize bearings are available in .010", .020" and .030" (0.25, 0.50, 0.75 mm). Do not use a new bearing with an old bearing and always install bearings in pairs.

2) If bearings are not within specifications, replace by installing pin tool C-3059 into crankshaft oil hole. Rotate crankshaft slowly until bearing is forced out. Insert new bearing and install pin tool C-3059 into oil hole. Turn crankshaft counterclockwise until new bearing is in position.

3) Use dial indicator to check crankshaft end play. If end play is excessive, install an oversize thrust plate on No. 7 bearing journal. Repeat procedure if necessary. Oversize thrust plates are available in .006", .012" and .018" (0.15, 0.30, 0.45 mm).

### CAMSHAFT

#### ENGINE FRONT COVER

**Removal** — Drain cooling system and remove radiator and fan shroud. Remove drive belts and idler pulley. Turn crankshaft until keyway is at 12 o'clock position. Use puller MH-061106 to remove crankshaft pulley and damper assembly. Remove idler pulley bracket and front cover.

**Installation** — Install new oil seal. Use sealing compound around gasket surface and install front cover over dowels on engine front plate. Install crankshaft and idler pulleys. Install drive belts, fan shroud and radiator. Fill cooling system and test.

#### TIMING GEAR ASSEMBLY

**Removal** — 1) Remove front cover and idler pulley bracket. Align timing marks and using camshaft gear puller DT-1001A (or equivalent), remove camshaft gear. Turn injection pump drive gear to allow notch in drive gear to clear idler gear teeth.

2) Loosen idler mount bolt, remove thrust plate and idler gear. Disconnect injector pipes at pump and fuel line from transfer pump. Disconnect transfer pump fuel filter and hoses. Loosen hold down bolt at base of injection pump. Remove pump and flange by pulling toward back of engine.

**Installation** — 1) Be sure No. 1 cylinder is at TDC, and install idler gear with alignment marks lined up on crankshaft gear. Install thrust plate and hold down bolt. Tighten to specifications. Install camshaft gear and thrust plate with alignment marks lined up with marks on idler gear. Install injection pump so that alignment marks on pump gear match alignment marks on idler gear. See Fig. 12.

**NOTE** — Be sure mounting flange scale is set at proper injection timing point.

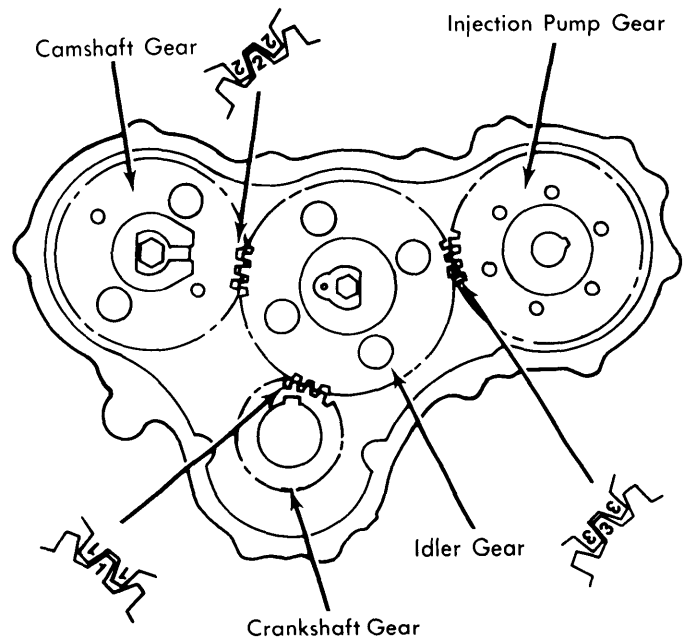

Fig. 12 Aligning Timing Gear Marks

# Chrysler Corp. 6 Engines

## 243" 6 CYLINDER DIESEL ENGINE (Cont.)

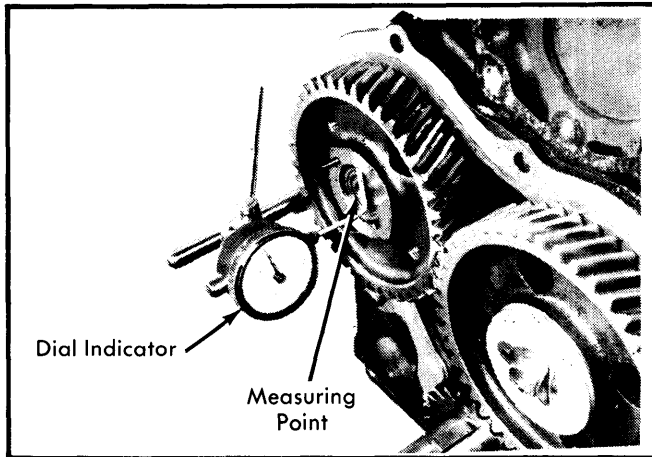

Fig. 13 Camshaft Gear End Play

2) Check camshaft end play with a dial indicator. End play should be between .002-.008" (0.05-0.20 mm). Replace camshaft thrust plate if end play is excessive. See Fig. 13. Check idler gear end play with a feeler gauge between gear and thrust plate. End play is .002-.006" (0.05-0.15 mm). If measurement is excessive, replace thrust plate. See Fig. 14.

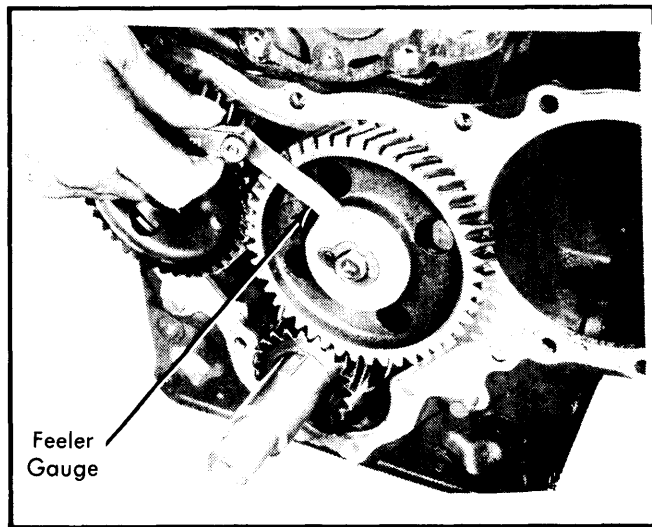

Fig. 14 Checking Idler Gear End Play

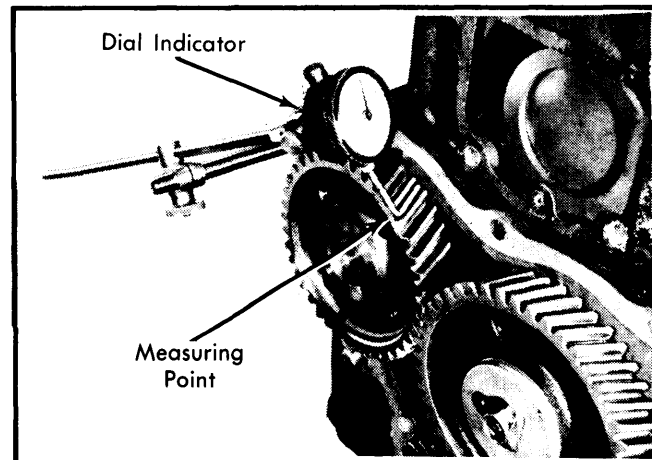

Fig. 15 Camshaft Gear Back Lash Check

3) Check timing gear backlash by mounting dial indicator so that lash is measured from gear tooth profile at right angle to gear shaft. See Fig. 15. Be sure hold down bolt at rear of pump is tight. Backlash should be .004-.009" (0.11-0.24 mm). Replace gear if backlash exceeds limit of 0.01" (0.3 mm).

### CAMSHAFT

**Removal** — With engine removed from vehicle, remove cylinder head, front cover, rocker arm assembly. Remove oil pan, oil pump and valve lifters. Remove thrust plate and remove camshaft out front of engine.

**CAUTION** — Use care not to damage bearings with camshaft lobes.

**Installation** — Install valve lifters and lubricate camshaft lobes and bearing journals and install camshaft into block. Install thrust plate, cylinder head and rocker arm assembly. Install oil pump and oil pan.

### CAMSHAFT BEARINGS

**Removal & Installation** — Use camshaft bearing removal/installation tool MH061070 (or equivalent), to remove bearings as shown in Fig. 16.

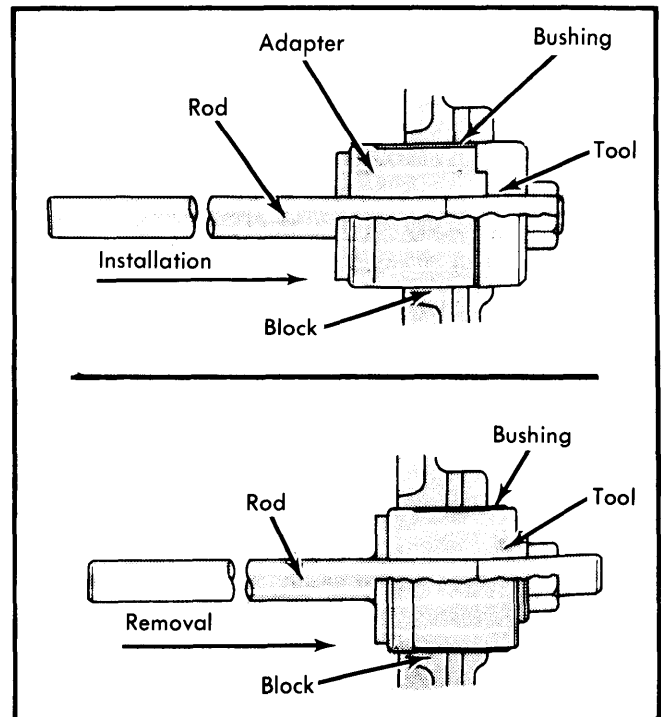

Fig. 16 Camshaft Bearing Removal and Installation

### ENGINE OILING

**Crankcase Capacity** — 7 quarts. Add 1 quart with filter change.

**Normal Oil Pressure** — 21-41.7 psi at 1000 RPM.

**Oil Filters** — Replace both filters at every oil change.

## 243" 6 CYLINDER DIESEL ENGINE (Cont.)

### ENGINE OILING SYSTEM

System is full pressure type with trochoid gear pump and two throw-away oil filters. Camshaft driven pump delivers oil into series of passages in engine. Should oil filters become clogged, differential pressure between inlet and outlet side of filter will increase and open the pressure relief valve. This allows oil to flow directly to engine, not through oil filters. To prevent damage to engine, an alarm switch on filter head warns operator that engine is being lubricated with unfiltered oil.

### OIL PUMP

**Removal** – Remove oil pan, pickup tube and strainer. Remove filter assembly to oil pump tube. Remove pump joint bolt and pump.

**Installation** – Clean parts thoroughly and check cover for scratches or grooves. Measure all clearances indicated in *Oil Pump Specification Table*. Replace all parts that fail to meet specifications or show signs of excessive wear. Prime pump before installation by filling rotor cavity with engine oil.

Oil Pump Specifications	
Application	Specification
Inner-to-Outer Rotor .....	.007" (.17 mm)
Outer Rotor-to-Cover .....	.0014-.004" (.035-.095 mm)
Outer Rotor-to-Body .....	.008-.01" (0.2-0.3 mm)
Shaft-to-Pump Body .....	.001-.003" (.032-.074 mm)

### ENGINE SPECIFICATIONS

GENERAL SPECIFICATIONS										
Year	Displ.		Carburetor	HP at RPM	Torque (Ft. Lbs. at RPM)	Compr. Ratio	Bore		Stroke	
	cu. ins.	cc					in.	mm	in.	mm
1978	3988	243.4	Fuel Inj.	100@3700	163@2200	20.0-1	3.62	92	3.94	100

VALVES							
Engine & Valve	Head Diam. In. (mm)	Face Angle	Seat Angle	Seat Width In. (mm)	Stem Diameter In. (mm)	Stem Clearance In. (mm)	Valve Lift In. (mm)
243" Int.	.....	45°	45°	.05-.107 (1.2-1.8)	.314 (8)	.002-.003 (.055-.085)	.408 (10.36)
Exh.	.....	45°	45°	.05-.107 (1.2-1.8)	.314 (8)	.003-.004 (.070-.100)	.....

PISTONS, PINS, RINGS						
Engine	PISTONS		PINS		RINGS	
	Clearance In. (mm)	Piston Fit In. (mm)	Rod Fit In. (mm)	Rings	End Gap In. (mm)	Side Clearance In. (mm)
243"	.006-.008 (.145-.210)	.0006 (.016)	.0008-.002 (.020-.051)	1	.012-.020 (.30-.50)	.0011-.002 (.028-.059)
				2,3,4	.012-.020 (.30-.50)	.0010-.0023 (.025-.059)

CRANKSHAFT MAIN & CONNECTING ROD BEARINGS							
Engine	MAIN BEARINGS				CONNECTING ROD BEARINGS		
	Journal Diam. In. (mm)	Clearance In. (mm)	Thrust Bearing	Crankshaft End Play In. (mm)	Journal Diam. In. (mm)	Clearance In. (mm)	Side Play In. (mm)
243"	2.754-2.755 (69.95-69.97)	.0012-.0035 (.03-.089)	No.7	.004-.01 (.10-.25)	2.281-2.282 (57.95-57.97)	.0015-.0044 (.039-.113)	.006-.018 (.15-.45)

# Chrysler Corp. 6 Engines

## 243" 6 CYLINDER DIESEL ENGINE (Cont.)

### ENGINE SPECIFICATIONS (Cont.)

VALVE SPRINGS			
Engine	Free Length	Compressed Length	Lbs. @ Comp. Length
243" Outer	2.01 (57.71)	1.771 (45)	35.5-39.2 (157.89-173.59)
Inner	1.7 (43.5)	1.530 (39)	15.22-16.54 (67.65-73.55)

CAMSHAFT			
Engine	Journal Diam. In. (mm)	Clearance In. (mm)	Lobe Lift In. (mm)
243" 1 & 2	2.145-2.146 (54.494-54.496)	.0016-.0035 (.040-.090)	.....
3	2.125-2.126 2.0863-2.0864 (52.994-52.996)	.....	

### TIGHTENING SPECIFICATIONS

Application	Ft. Lbs. (Mkg)
Camshaft Gear Bolt	21.7-28.9 (3.04-4.01)
Camshaft Thrust Plate	10.8 (1.52-2.07)
Connecting Rod Cap	61.5-68.7 (8.43-9.54)
Crankshaft Pulley	289.3 (40.00)
Cylinder Head Bolts	90.4 (12.44)
Flywheel	75.9-83.2 (10.51-11.48)
Flywheel Housing Bolt	21.7-28.9 (3.04-4.01)
Idle Gear Bolt	21.7-28.9 (3.04-4.01)
Main Bearing Cap	65.1-72.3 (8.99-9.95)
With "H" Mark	76.7-85.4 (10.65-11.75)
Oil Pan Bolts	12.3-16.6 (1.66-2.35)
Engine Front Cover	5.1-9.4 (.69-1.24)
Water Pump Flange Nut	65.1 (8.99)