

## OPEN STEERING KNUCKLES

Chrysler Corp.  
 Ford Motor Co.  
 General Motors  
 International Harvester  
 Jeep

### DESCRIPTION

Open steering knuckles on front drive axles give the advantage of a sharper turning angle which decrease vehicle's turning radius. All of the vehicle weight is borne by the axle housing and steering knuckle; the axle is free floating. The knuckles are mounted to the axle housing yoke in two different ways: Dodge uses spring-loaded, tapered roller bearings and pivot pins on the W300 (optional on W200). All other models use ball joints. Other than the unique parts required for front-wheel drive, these axle assemblies are mechanically identical to other models of Dana/Spicer axles. Open knuckle assemblies are used with both part-time and full-time transfer cases.

### OVERHAUL

#### DISASSEMBLY

**All Models With Ball Joints** – 1) Remove wheel, brake drum (or disc brake assembly) and wheel hub. See *Locking Hubs in this Section*. Remove spindle. Examine axle bore of knuckle; if seal is present, drive out with punch from the inside. Slide axle shaft out through steering knuckle.

2) Disconnect steering rod(s) from knuckle. Remove nut from lower ball joint stud. Examine underside of knuckle; if a snap ring is present that retains lower ball joint socket, remove snap ring. Remove cotter pin from upper ball joint nut, then screw nut up until it is flush with top of ball joint stud. Using suitable

adapter plate and pulling tool, loosen steering knuckle from axle-end yoke. Remove upper ball joint nut, and remove steering knuckle.

3) Using suitable tools, press ball sockets from knuckle. Remove threaded sleeve from yoke. Clean all components with suitable solvent and blow dry with compressed air. Inspect all parts for burrs, chips, wear, flat spots or cracks. Replace all damaged parts and parts showing excessive wear.

**All Models With Pivot Pins** – 1) Remove wheel, disc brake assembly, and hub cap. Using suitable tool (C-4020), remove snap ring. Remove drive flange and discard gasket. Remove locking devices, bearing adjusting nut, and outer wheel bearing. Carefully slide hub and rotor assembly from spindle. Remove inner brake shoe from adapter.

2) Remove nuts and washers holding brake splash shield, brake adapter, and spindle to steering knuckle. Remove spindle from knuckle. Slide inner and outer axle shaft out of axle housing. Remove steering linkage from knuckle. Remove pivot pin caps from knuckle. Remove spring and white nylon seat from upper pivot pin. To remove knuckle from housing, swing out at bottom, then lift up and off upper pivot pin. Using suitable tool, remove upper pivot pin. Remove seal. Using suitable tools, press lower pivot pin assembly from axle housing.

#### REASSEMBLY

**All Models With Ball Joints** – 1) Place new lower ball socket into position on knuckle. Lower socket has shorter shaft and no cotter pin hole. Using suitable adapter, press into place in bore. Check bore-to-socket clearance; it must be less than .0015". If snap ring was removed, reinstall. Install upper socket into knuckle; check clearance as with lower socket. Install threaded sleeve into axle-end yoke.

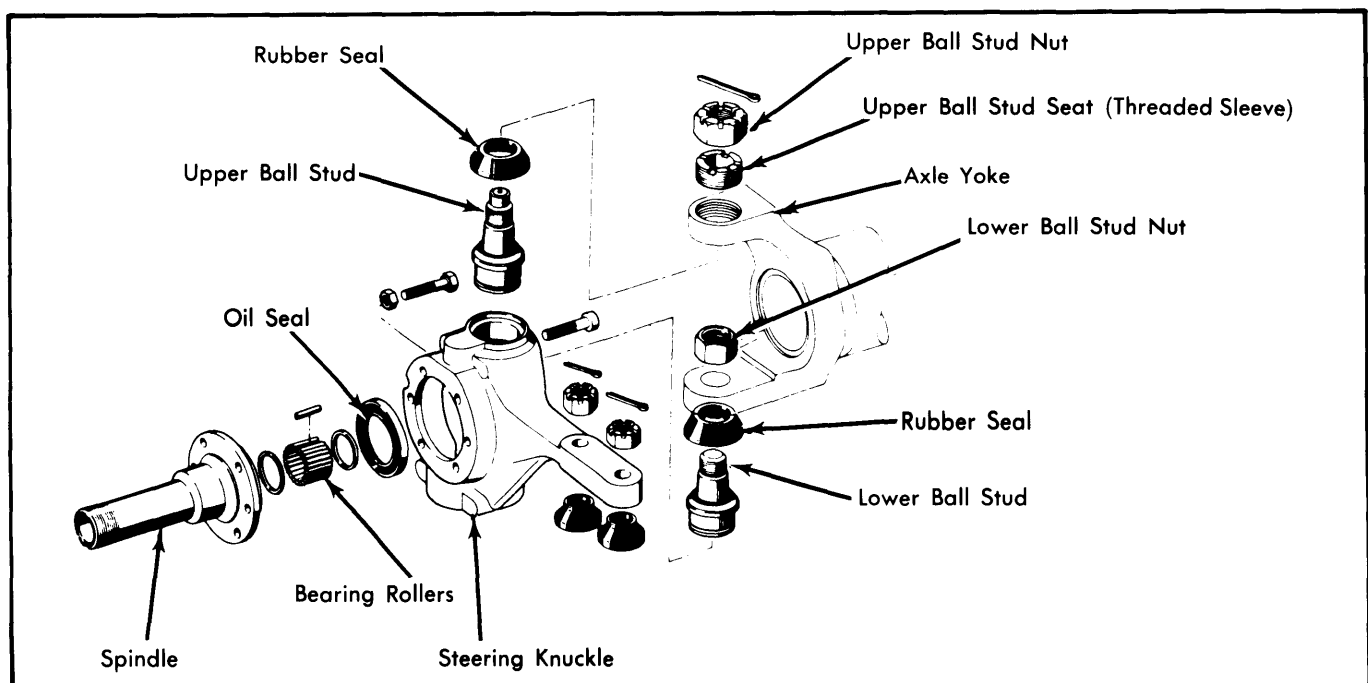

Fig. 1 Exploded View of Ball Joint Type Open Steering Knuckle Assembly

# 4-Wheel Drive Steering Knuckles

## OPEN STEERING KNUCKLES (Cont.)

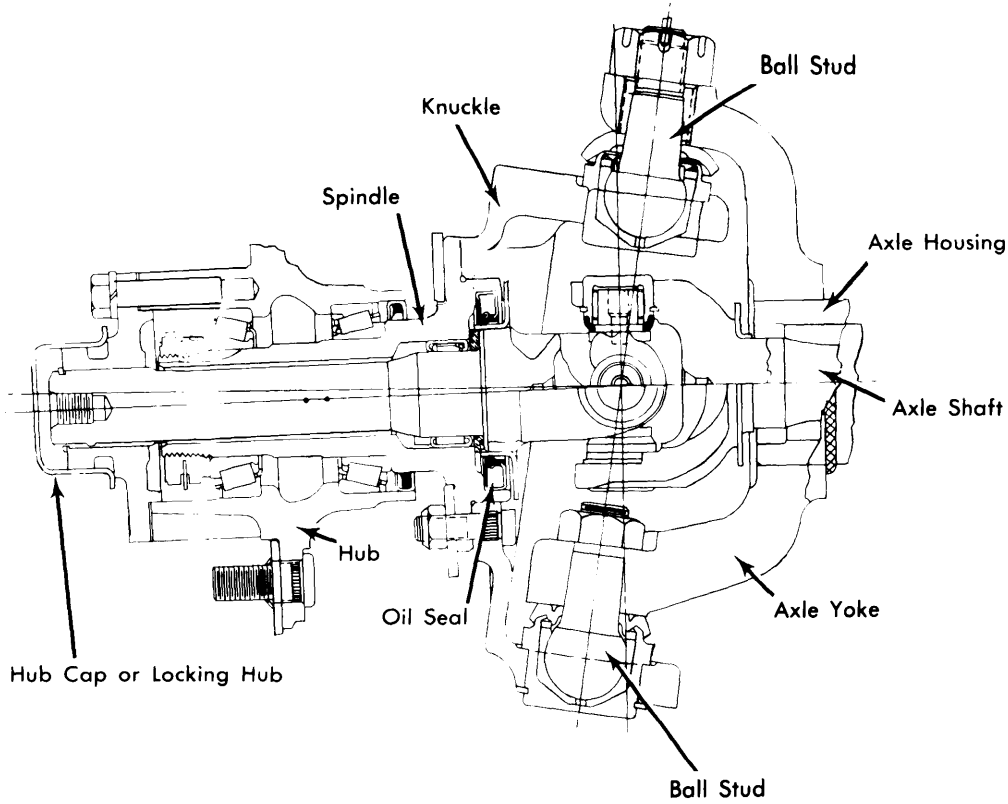

Fig. 2 Sectional View of Ball Joint Type Open Steering Knuckle

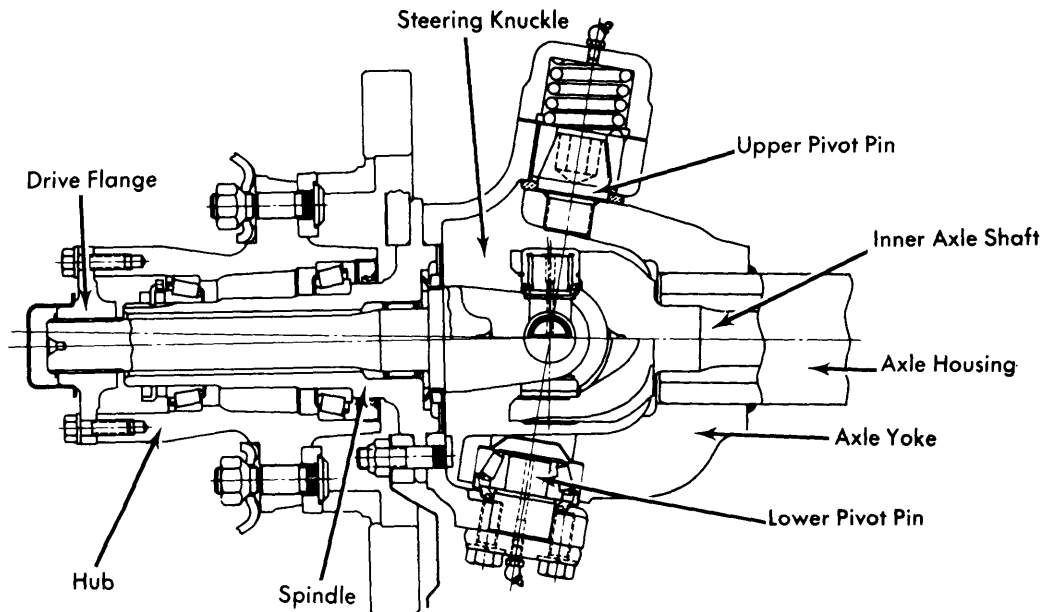

Fig. 3 Sectional View of Pivot Pin Type Open Steering Knuckle

## OPEN STEERING KNUCKLES (Cont.)

2) Adjust threaded sleeve so that approximately two threads are exposed above top of yoke. Assemble knuckle to yoke. Install NEW nut on bottom ball joint and tighten to specifications. Tighten threaded sleeve to specifications (this loads ball joints correctly). Install ball joint upper nut and tighten to specifications. To complete reassembly, reverse disassembly procedure.

**NOTE** — When aligning upper ball joint nut to install cotter pin, always tighten nut to align. Never loosen nut to align holes.

**All Models With Pivot Pins** — 1) Lubricate lower pivot pin assembly with chassis lube. Using suitable tools, press seal and lower bearing cup into axle yoke. Using suitable adapter (D-192) and torque wrench (DD-994), install upper socket pin and tighten to 950 ft. lbs. to properly seat pin. Install seal over pin.

2) Position steering knuckle over socket pin. Fill lower socket cavity with chassis lube. Work lower knuckle cap into place on knuckle housing. Install attaching hardware and tighten. Lubricate upper socket pin with chassis lube. Align upper socket sleeve (white nylon) in keyway of steering knuckle and slide into position. Install new gasket over upper steering knuckle studs, then position spring over sleeve. Install cap and tighten bolts. **NOTE** — There is no preload adjustment; the spring maintains proper preload. To complete reassembly, reverse disassembly procedure.

### ADJUSTMENT

#### TURNING ANGLE

Turning angle stop screws are located at rear of steering knuckle just above axle centerline. To adjust, loosen lock nut on turning angle stop screw. Using a turntable to measure

angle, adjust stop screw to obtain specified angle, then tighten lock nut without changing setting.

#### Turning Angle Specifications

Application	Degrees
Jeep	
"CJ" Models .....	29
All Others .....	36-37
International Harvester .....	37-38

**NOTE** — Turning angle adjustment applies only to Jeep and IHC vehicles.

#### TIGHTENING SPECIFICATIONS

Application	Ft. Lbs.
<b>Ball Joint Type</b>	
Threaded Sleeve (Upper Ball Stud Seat)	
Ford & Chrysler Corp. ....	40
All Others .....	50
Upper Ball Joint Nut	
Chrysler Corp. ....	135
All Others .....	100
Lower Ball Joint Nut	
Chrysler Corp. ....	135
All Others .....	80
<b>Pivot Pin Type</b>	
Pivot Pin Cap Bolts .....	70-90
Drag Link to Steering Knuckle .....	60
Tie Rod to Steering Knuckle .....	45