

## GENERAL MOTORS 8 1/2" & 8 7/8" RING GEAR

**Chevrolet**  
 All 10 Series  
 G20  
**GMC**  
 All 1500 Series  
 G2500

### DESCRIPTION

The axle assembly is the hypoid gear type with integral carrier housing. It is used on light duty vehicles with semi-floating axles. The pinion bearing preload adjustment is made with a collapsible spacer. The differential side bearing preload adjustment and the drive pinion depth adjustment are made by shims. A removeable ten bolt housing cover permits inspection and minor servicing of differential without removal from vehicle. Service procedures are the same for both size assemblies, except for some tightening specifications and special tool numbers.

### AXLE RATIO & IDENTIFICATION

General Motors uses several types of axles in its vehicles. The 8 1/2" and 8 7/8" axles can be distinguished from the others by the configuration of its housing cover (see illustration) and the number of attaching bolts. To determine the axle ratio, divide the number of teeth on the ring gear by the number of teeth on the drive pinion.

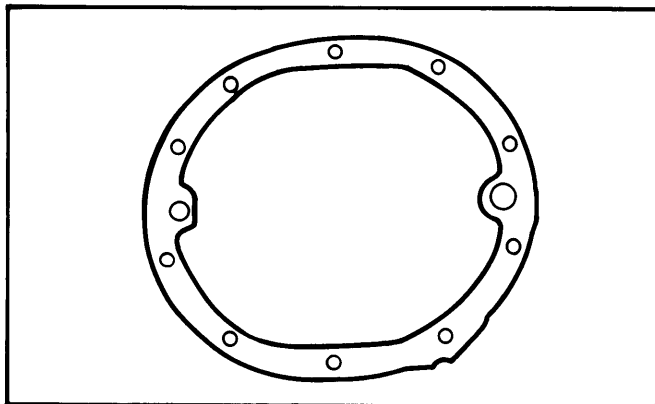

Fig. 1 8 1/2" & 8 7/8" Ring Gear Housing Cover Gasket for Identification Purposes

### REMOVAL & INSTALLATION

#### AXLE SHAFTS & BEARINGS

1) Raise vehicle on hoist and remove wheel and tire assembly and brake drum. Drain lubricant and remove housing cover. Remove differential pinion shaft lock screw. On vehicles with 8 7/8" ring gear and Eaton limited slip differentials (see Eaton Positraction in this Section for identification), go to step 2); on all other models, proceed as follows: Remove differential pinion shaft, then push flanged end of axle shaft towards center of vehicle. Remove "C" lock from splined end of axle shaft, then remove axle shaft.

2) On vehicles with 8 7/8" ring gear and Eaton limited slip differential, proceed as follows: With pinion shaft lock screw removed, withdraw pinion shaft part way. Rotate differential case until pinion shaft touches edge of housing (see illustration). Reach into case with screwdriver and rotate "C" lock until its open end points directly inward. When "C" lock is

properly positioned, axle shaft can be pushed inward permitting removal of "C" lock. **CAUTION** — Do not hammer on axle shaft; it will slide in easily when "C" lock is properly positioned.

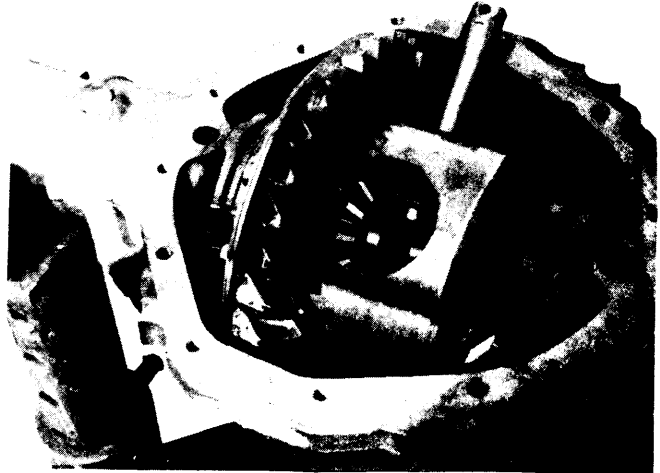

Fig. 2 Positioning Case for Axle Removal

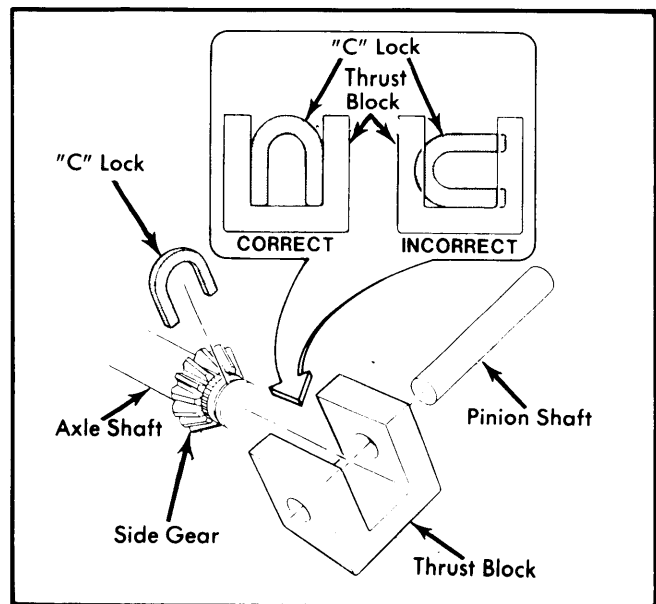

Fig. 3 View Showing Correct Positioning of "C" Lock for Removal

3) With axle shaft removed, insert suitable tool (J-23689) into bore in axle housing and position behind bearing so that tool grasps bearing outer race. Attach slide hammer to tool and remove bearing.

4) To install bearing, use suitable installation tool (J-23690). Lubricate bearing cavity before installing. Drive bearing in until it bottoms in cavity. Install seal using suitable seal installation tool (J-21128). Drive seal in until tool bottoms against axle tube.

## GENERAL MOTORS 8 1/2" &amp; 8 7/8" RING GEAR (Cont.)

## PINION FLANGE &amp; SEAL

1) Raise rear of vehicle and allow axle assembly to hang free. Disconnect rear universal joint and tie propeller shaft out of way. Note and record pinion bearing preload by rotating pinion shaft through several revolutions using an INCH lb. torque wrench, then mark relationship of pinion flange and shaft for reassembly. Count the number of exposed threads on pinion shaft. Hold yoke with a suitable holding tool (J-8614-11) and remove self-locking nut. Remove yoke using a suitable puller. Pry old seal out of housing.

2) Pack seal lip cavity with lithium-base extreme pressure lubricant. Place seal in bore. Using suitable gauge plate (J-22804-1) and seal driver (J-21057) drive seal into place. Make sure seal is square in carrier. Pack cavity between end of pinion splines and pinion flange with a non-hardening sealer.

3) Using a suitable installation tool (J-8614-11) install flange on pinion shaft. Install washer and nut. Install nut in original position taking note of scribe marks and number of exposed threads. Measure pinion preload. Tighten nut in small increments until preload exceeds original figure by 1-5 INCH lbs. Install propeller shaft and lower vehicle.

**CAUTION** — Do not attempt to hammer flange onto pinion shaft, as it will damage ring gear and pinion.

## AXLE ASSEMBLY REMOVAL

Raise vehicle and position on safety stands. Raise drive axle with a jack to relieve tension from springs and shocks. Disconnect propeller shaft from flange and tie propeller shaft up out of way. Disconnect shock absorbers at axle. Disconnect axle vent hose. Disconnect hydraulic brake hose at connect on housing. Remove brake drums and disconnect parking brake cable. Remove axle "U" bolt nuts, "U" bolts, spacers and clamp plates. Lower axle assembly and remove from vehicle.

## OVERHAUL

## DISASSEMBLY

**NOTE** — Check and record ring gear backlash and pinion bearing preload before disassembly.

Remove axle shafts, differential pinions, side gears and thrust washers. Mark side bearing caps for reassembly reference, remove caps and pry differential case from housing. Remove differential bearing cups and shims and place with correct bearing cap. Remove ring gear from case. Remove pinion nut, pinion flange and seal as previously outlined. Thread pinion nut half way on to shaft. Temporarily install differential cover with two bolts. Tap end of pinion, against nut, with a soft drift and hammer. Care must be taken not to damage pinion bearings. Remove front pinion bearing. Remove cover and remove drive pinion. Discard oil seal, pinion nut and collapsible spacer.

## REASSEMBLY &amp; ADJUSTMENT

**Case Assembly** — Install ring gear squarely (use guide pins if necessary) onto case and tighten ring gear bolts evenly and alternately. Install side gears, differential pinions and thrust washers into case. Install differential pinion shaft and lock screw and tighten lock screw.

**Drive Pinion Depth & Bearing Preload** — 1) Drive pinion rear bearing shim thickness must be determined whenever a new axle housing, ring and pinion set, or pinion bearings are installed. Shim pack thickness is determined by using suitable gauging tool set (J-21777).

2) If removed, install pinion bearing cups into housing, then place lubricated pinion bearings into cups. Position gauge plate (J-21777-29 for 8 1/2" or J-21777-36 for 8 7/8") and rear pinion bearing pilot on preload stud, then install through rear pinion bearing, front pinion bearing, and front pinion bearing disc (J-21777-42). Install hex nut until snug, then rotate bearings to insure proper seating. Hold preload stud stationary with a wrench on flats, then tighten hex nut until 20 INCH lbs. are required to rotate bearings.

3) Mount side bearing gauging discs (J-21777-45) on ends of arbor, then place arbor into carrier making sure discs are properly seated. Install side bearing caps and bolts, then tighten bolts to avoid movement. Position dial indicator on mounting post of arbor, with contact button resting on top surface of plunger. Preload dial indicator 1/2 revolution, then tighten in this position.

4) Place plunger onto gauging area of gauge plate. Rock plunger rod slowly back and forth across gauging area until dial indicator reads greatest deflection, then set indicator to zero. Repeat rocking action several times to verify setting. Once zero reading is obtained, swing plunger until it is removed from gauging area. Dial indicator will now read required pinion shim thickness for a "nominal pinion". Record this reading.

5) Check drive pinion for painted or stamped markings on pinion stem, or a stamped code number on small end of pinion gear. If marking is found to be plus or minus number (for example, +2 or -5) add or subtract that many thousandths from indicator reading. This will then be thickness of rear pinion bearing shim pack. **NOTE** — If no markings are found on pinion, use dial indicator reading as shim thickness.

6) Remove bearing caps and gauging tool from housing. Place selected shim pack on pinion gear, then install lubricated pinion bearing onto pinion gear shaft using suitable press.

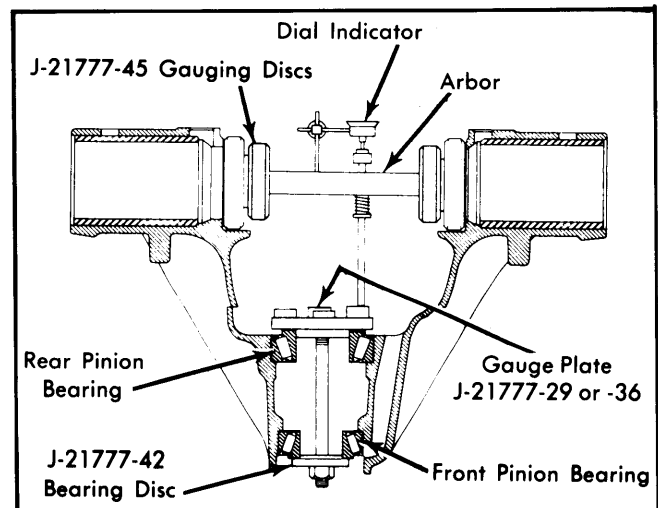

Fig. 4 Sectional View Showing Use of Pinion Depth Tool Set J21777

## GENERAL MOTORS 8 1/2" & 8 7/8" RING GEAR (Cont.)

7) Install a new collapsible spacer over pinion gear shaft, then position pinion assembly in housing. While holding pinion forward, carefully drive front pinion bearing onto pinion gear shaft until a few threads are exposed. Install seal, pinion flange, washer and nut, and tighten until all end play is removed. Rotate pinion several times to seat bearings, then check preload using an INCH lb. torque wrench. Continue tightening nut and checking preload until specified preload is obtained.  
**CAUTION** — Do not back off nut to lessen preload. If preload is exceeded, a new collapsible spacer must be installed and nut retightened until proper preload is obtained.

**Side Bearing Preload** — Install differential assembly into housing. If original bearings and differential case are reused, use a shim pack .002" thicker (each side) than original shim pack. **NOTE** — Always replace production shims with .170" service spacer and appropriate additional shims. If new parts are being installed, determine correct preload as follows: Select two shims whose total thickness will permit a feeler gauge at least .010" thick to be inserted between shim and cup and install these shims between right bearing cup and carrier cup seat. Loosely install left bearing cap. With left bearing cup and differential case against left cup seat, measure distance between right side shims and cup seat (insert progressively larger feeler gauges until there is a snug, not tight, fit). Add .008" to total of both shim pack and feeler gauge thickness. This is total shim pack necessary for correct bearing preload. Divide shims equally between both sides and install. With bearing caps in place, tighten bolts alternately and evenly.

**Backlash & Final Assembly** — Check backlash at four locations around ring gear, using a dial indicator mounted to

axle housing. Variation should not exceed .001". If backlash is not within specifications, adjust side bearing shims as necessary. **CAUTION** — Total shim pack thickness must not be changed. If a shim is removed from one side, the same thickness shim must be added to other side. After adjustment is completed, make a tooth contact pattern test and make any necessary corrections. Install axle shafts, wheels and housing cover.

### AXLE ASSEMBLY SPECIFICATIONS

Application	Specification
Ring Gear Backlash	
Preferred .....	.005-.008"
Suitable .....	.003-.010"
Side Bearing Preload .....	.008"
Pinion Bearing Preload	
Used Bearings .....	5-10 INCH Lbs.
New Bearings .....	15-30 INCH Lbs.

### TIGHTENING SPECIFICATIONS

Application	Ft. Lbs.
Ring Gear-to-Differential Case .....	90
Side Bearing Cap .....	60
Pinion Shaft Lock Bolt .....	20-25
Housing Cover .....	20

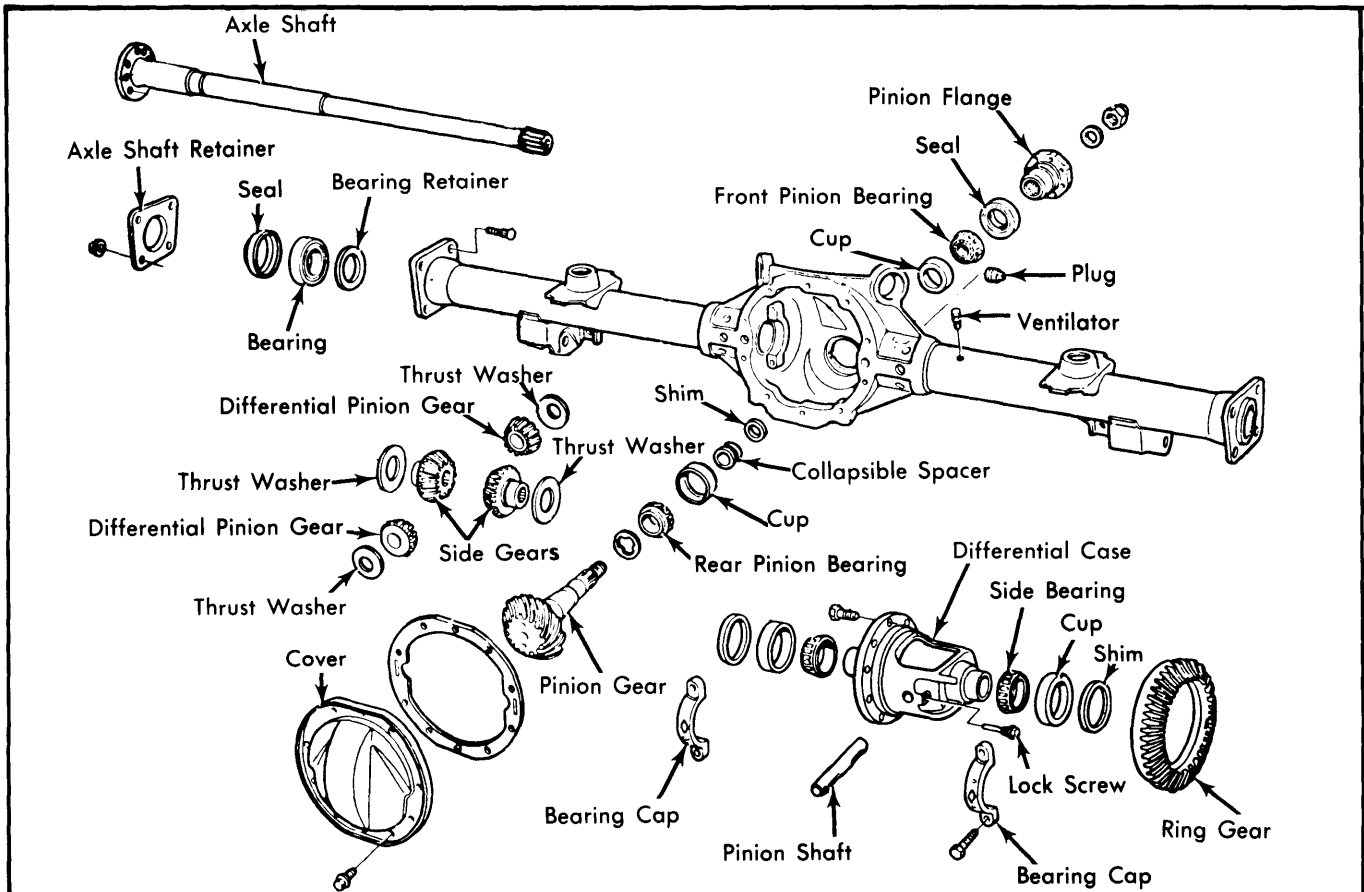

Fig. 5 Exploded View of General Motors 8 1/2" & 8 7/8" Ring Gear Axle Assembly