

400" & 440" V8 ENGINE

GENERAL SPECIFICATIONS							
Year	Displ. Cu. Ins.	Carburetor	HP at RPM	Torque (Ft. Lbs. at RPM)	Compr. Ratio	Bore	Stroke
1977	400"	2-Bbl.	8.2-1	4.342"	3.375"
	440-1"	4-Bbl.	8.2-1	4.320"	3.750"
	440-3"	4-Bbl.	8.2-1	4.3215"	3.750"

ENGINE IDENTIFICATION

The Engine Identification Number is located as follows:

400" – Adjacent to distributor on right side of block.

440"-1 – Adjacent to front tappet rail on top of block.

440"-3 – Adjacent to water pump housing on top of block.

First five digits contain engine cubic inch displacement and are as follows:

Application	Digits
400"	400
440"-1 & 440"-3	①440

① – 440"-3 is designated by numeral "3" stamped below engine number.

SPECIAL ENGINE MARKS

Information identifying special engine marks is stamped on cylinder block after serial number and is decoded as follows:

Maltese Cross (✕) – .001" undersize crankshaft journals. "M" or "R", representing "main" or "rod" followed by the cylinder number of journals concerned, will be found stamped on a crank shaft counterweight.

Maltese Cross (✕) & "X" – .010" undersize crankshaft journals. "M" or "R" will be found stamped on a crankshaft counterweight.

"A" – Indicates all cylinder bores .020" oversize.

"♦" – Indicates .008" oversize tappets.

"O/S" – Indicates .005" oversize valve stems.

ENGINE REMOVAL

See *Engine Removal at end of Engine Section.*

INTAKE MANIFOLD

Removal – 1) Drain cooling system. Remove air cleaner. Remove alternator and air pump (if equipped). Disconnect fuel inlet line and accelerator linkage at carburetor. Remove closed ventilation system and evaporative control system.

2) Disconnect vacuum lines at carburetor and distributor. Disconnect distributor cap and coil wires. Disconnect heater hose at manifold. Disconnect heat indicator switch connector. Remove intake manifold bolts. Remove intake manifold, carburetor and coil as an assembly.

Installation – To install intake manifold reverse removal procedure. Make sure all gasket surfaces are clean. Tighten manifold bolts to specification.

CYLINDER HEAD

Removal – Remove intake manifold as described previously. Remove tappet chamber cover, rocker arm covers, and gaskets. Remove exhaust manifolds. Remove rocker arm shaft assembly and push rods. **NOTE** – Identify push rods to ensure installation in original location. If equipped with air conditioning, raise rear of compressor and position 3/8" thick block of wood between bracket and engine block to allow clearance for cylinder head removal. Remove cylinder head attaching bolts, cylinder head and gasket.

Installation – Clean all gasket surfaces of cylinder block and head. Coat new gasket with suitable sealer. Install gasket and cylinder head on cylinder block. Install cylinder head bolts and tighten to specifications in two steps. Use tightening sequence shown in illustration. **NOTE** – Do not retighten cylinder head bolts after engine has been operated when embossed steel head gaskets are used.

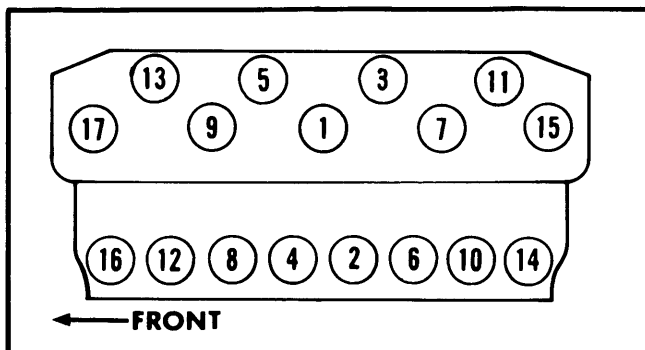

Fig. 1 Diagram Showing Correct Cylinder Head Tightening Sequence

400" & 440" V8 ENGINE (Cont.)

VALVES							
Engine & Valve	Head Diam.	Face Angle	Seat Angle	Seat Width	Stem Diameter	Stem Clearance	Valve Lift
400" & 440"-1							
Intake	2.08"	45°	45°	$\frac{1}{16}$ -. $\frac{3}{32}$ "	.3723-.3730"	.0011-.0028"	.434"
Exhaust	1.75"	45°	45°	$\frac{3}{64}$ -. $\frac{1}{16}$ "	① .3713-.3720"	② .0021-.0038"	.430"
440"-3							
Intake	2.08"	45°	45°	$\frac{1}{16}$ -. $\frac{5}{64}$ "	.3718-.3725"425"
Exhaust	1.74"	45°	45°	$\frac{3}{64}$ -. $\frac{1}{16}$ "	.3710-.3720"430"

① — Hot end is given. Cold end is .3723-.3730".

② — Hot end is given. Cold end is .0011-.0028"

VALVE ARRANGEMENT

E-I-I-E-E-I-I-E (Both banks, front to rear).

VALVE GUIDE SERVICING

Wear Check — Remove valve springs and install suitable sleeve over valve stem and install valve in cylinder head. Attach suitable dial indicator to cylinder head and position indicator at a right angle to valve stem being measured. Total sideplay should not exceed .017". If dial reading is excessive or stems are scuffed or scored, ream guides for installation of valves with oversize stems.

Servicing — Ream valve guides to next oversized valve stem if necessary. Oversize valve stems are available in .005", .015", and .030" oversize. **NOTE** — Do not attempt to ream guides from standard diameter to largest oversize in one step. Use reaming tools in step sequence until desired oversize is obtained.

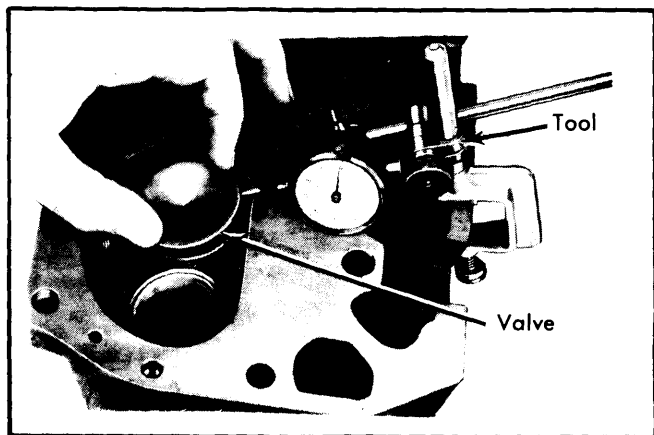

Fig. 2 Using Dial Indicator to Measure Valve Stem-to-Guide Clearance

VALVE STEM OIL SEALS

Cup or umbrella type oil seals are used on all engines. Coat all valve stems with oil before inserting in cylinder head. Press new seals squarely over valve guide using valve stem as a guide. Do not force seal against top of guide as sealing tip pressure of seal will be greatly reduced.

VALVE SPRINGS			
Engine	Free Length	PRESSURE (LBS.)	
		Valve Closed	Valve Open
400" & 440"-1	2 $\frac{5}{8}$ "	121-129@1 $\frac{5}{64}$ "	192-208@1 $\frac{1}{16}$ "
Int. & Exh.			
440"-3	2 $\frac{3}{64}$ "	121-129@1 $\frac{5}{64}$ "	192-208@1 $\frac{1}{16}$ "
Int.			
Exh.	2 $\frac{23}{64}$ "	118-128@1 $\frac{4}{64}$ "	200-210@1 $\frac{5}{16}$ "

VALVE SPRINGS

Removal — With cylinder head removed, compress valve springs using a suitable tool (C-3422A). Remove valve retaining locks, retainers or rotators, cup seals and valve springs. Remove any burrs from valve stem lock grooves to prevent damage to valve guide and identify valves to insure installation in original location.

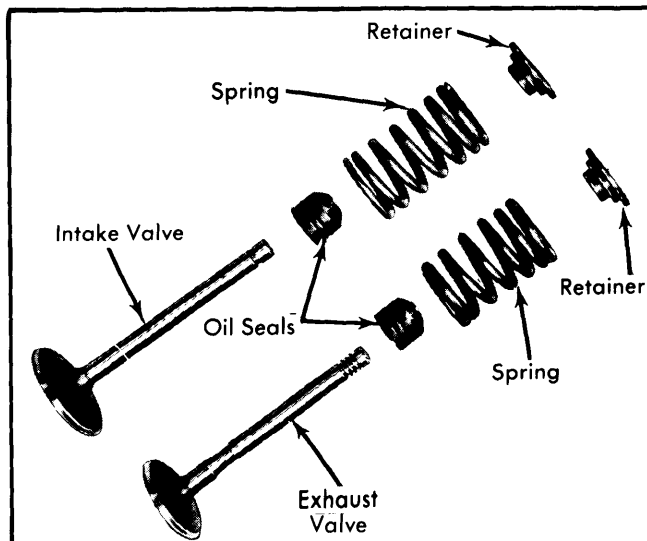

Fig. 3 Exploded View of Intake & Exhaust Valve Assemblies

Inspection — Whenever valve springs have been removed, they must be tested. Using a suitable tester, valve springs must be within specifications. Replace springs which do not meet specifications. Inspect each valve spring for squariness using a steel square and surface plate. If spring is more than $\frac{1}{16}$ " out-of-square, a new spring must be installed.

400" & 440" V8 ENGINE (Cont.)

Installation — Coat valve stems with engine oil and insert valves in cylinder head. If valves or seats are reground, check valve stem height using suitable tool (C-3648). If valve is too long, grind off tip until length is within limits. Install new seals over valve guides. Install valve springs, retainers or rotators. Compress valve springs using suitable tool (C-3422A), install valve retaining locks and release tool.

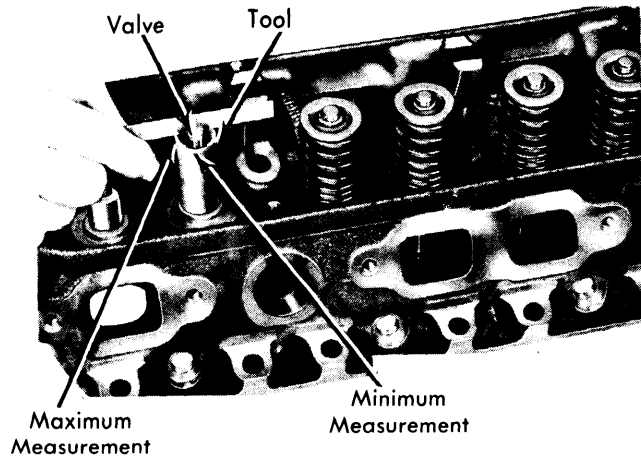

Fig. 4 Measuring Valve Stem Installed Length

VALVE SPRING INSTALLED HEIGHT

If valves and/or seats are reground, measure installed height of springs. Measurement is taken from bottom of spring seat in cylinder head to bottom surface of spring retainer.

NOTE — If spacers are installed, measure from top of spacer. On 440"-3 (Motor Home) installed height should be $1\frac{53}{64}$ - $1\frac{57}{64}$ " for intake valves and $1\frac{45}{64}$ - $1\frac{49}{64}$ " on exhaust valves. On all other engines, installed height is $1\frac{53}{64}$ - $1\frac{57}{64}$ " on both exhaust and intake valves. If not within specifications, install a $\frac{1}{16}$ " spacer at head counterbore to correct spring height.

CAUTION — Do not shim to a height less than specifications.

ROCKER ARM ASSEMBLY

Rocker arms are stamped steel and are arranged on a rocker arm shaft. Rocker arm shaft is held in place by bolts and stamped steel retainers attached to five brackets on the cylinder head. Rocker arms may be identified as "right" and "left" as shown in illustration.

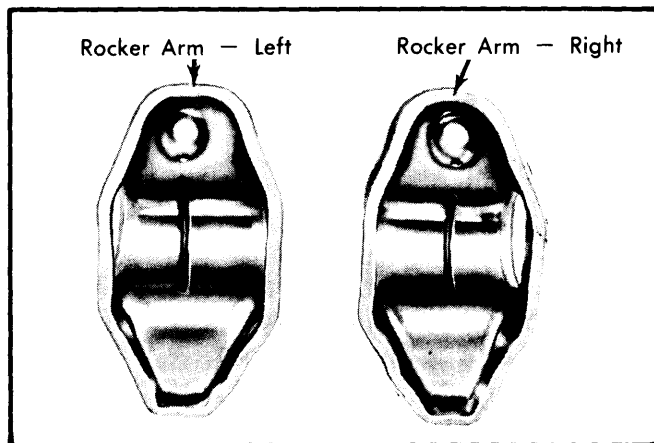

Fig. 5 Identification of Left & Right Side Rocker Arms

Removal — Remove cylinder head cover and gasket. Remove rocker arm shaft bolts and retainers. Remove rocker arm and shaft assembly.

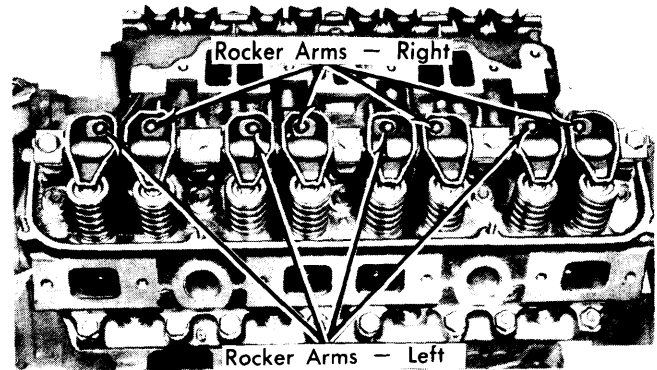

Fig. 6 Rocker Arm Location On Rocker Shaft

Installation — If rocker arm assemblies are taken apart, reassemble as shown in illustration. Long stamped steel retainers must be in number two and number four positions on shaft. Install rocker arm shafts with $\frac{3}{16}$ " lubrication holes pointing down into rocker arms to ensure that 15° angle of holes point outward toward valve end of rocker arms as shown in illustration.

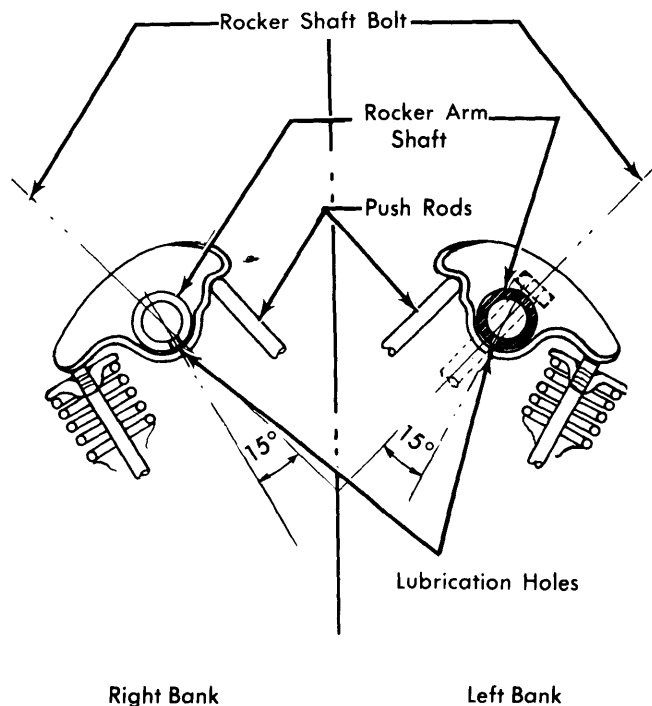

Fig. 7 Rocker Arm Shaft Lubricating Holes Alignment

400" & 440" V8 ENGINE (Cont.)

HYDRAULIC VALVE LIFTER ASSEMBLY

NOTE — Lifters are serviced as complete assemblies only. Parts are not interchangeable between lifters. If any component of lifter is worn or damaged, complete lifter must be replaced.

To test, remove cap from plunger (see illustration) and plunger from tappet body. Fill tappet body with clean kerosene and install plunger and cap. Place lifter upright in Lifter Testing Pliers and check leak down. If lifter collapses immediately, disassemble, clean and retest. If rapid leak down still occurs, replace lifter. Use a straightedge to check all tappets for a negative crown. If a negative crown (dish) is observed, tappet must be replaced.

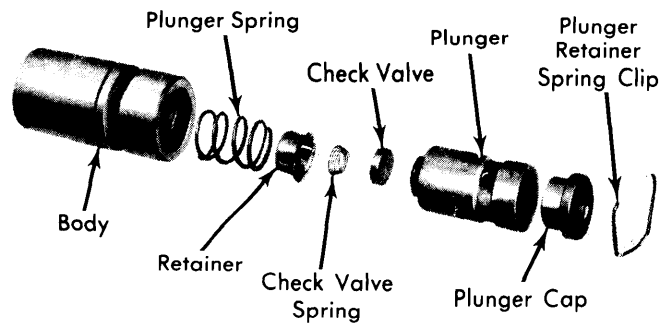

Fig. 8 Exploded View of Typical Hydraulic Lifter Assembly

PISTONS, PINS, RINGS						
Engine	PISTONS	PINS		RINGS		
	Clearance	Piston Fit	Rod Fit ①	Rings	End Gap	Side Clearance
400" & 440"-1	.0003-.0013"	.00045-.00075"	.0007-.0014"	1 & 2 3	.013-.023" .015-.055"	.0015-.0030" .000-.005"
440"-3	.0003-.0013"	.00045-.00075"	.0007-.0012"	1 & 2 3	.013-.023" .015-.055"	.0015-.0030" .000-.005"

① — Interference fit.

OIL PAN

See Oil Pan Removal at end of Engine Section.

PISTON & ROD ASSEMBLY

NOTE — Following procedures are with cylinder head and oil pan removed.

Removal — Remove ridge at top of cylinder bores using suitable tool before removing pistons from block.

NOTE — Keep tops of pistons covered during this procedure. Rotate crankshaft and inspect connecting rods and rod caps for cylinder identification. Identify them if necessary. Remove rod cap and push each piston and rod assembly out top of cylinder bore being careful not to nick crankshaft journals. Install rod caps on mating rods.

Installation — 1) Before installing piston and connecting rod assemblies into cylinder block, compression ring gaps must be staggered so neither is in line with oil ring rail gaps and "TOP" must be facing top of piston. On all engines, oil expander ends must be positioned under notch on piston, and oil ring gaps should be facing middle of engine upon installation and spread 3" apart.

2) Immerse piston head and rings in clean engine oil and slide suitable ring compressor over piston and tighten.
NOTE — Do not allow position of rings to change during ring compressor installation and tightening.

3) Rotate crankshaft so connecting rod journal is on center of cylinder bore. Insert rod and piston assembly into cylinder bore and guide rod over the crankshaft journal, taking care not to nick the journal. **NOTE** — Notch on top of piston must face front of engine and larger chamfer of connecting rod bore must be installed toward crankshaft journal fillet.

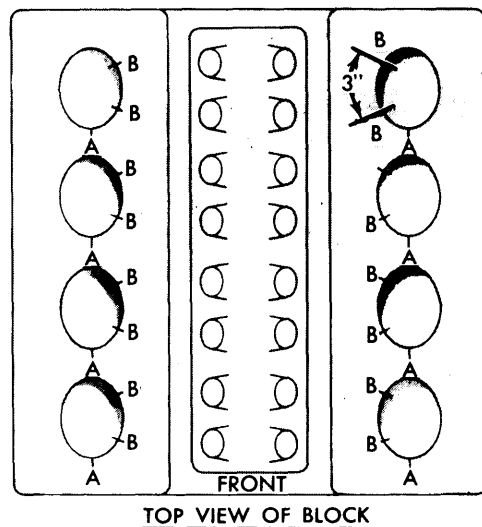

A — Expander Gaps B — Rail Gaps

Fig. 9 Diagram Showing Proper Oil Ring Gap Positioning

4) Tap piston into cylinder bore using wooden handle of a hammer and guide connecting rod into place on crankshaft journal. Install rod cap and tighten. Repeat procedure for each piston assembly.

FITTING PISTONS

Pistons should be measured 90° to piston pin axis at top of skirt. Measure cylinder bore halfway down the bore 90° to crankshaft center line. Pistons and cylinder bores should be measured at normal room temperature, 70°F.

400" & 440" V8 ENGINE (Cont.)

PISTON PINS

Removal — Use suitable tool for piston pin removal as follows:

Install pilot on main screw (see illustration) and install screw through piston pin. Install anvil (with spring removed) over threaded end of main screw with small end of anvil against

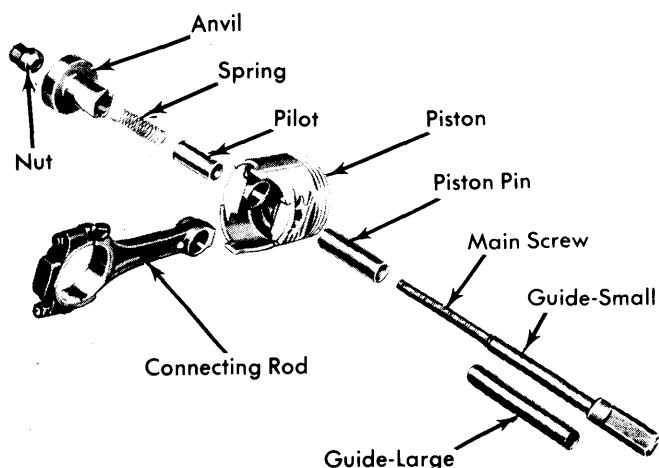

Fig. 10 Correct Procedure to Removal & Install Piston Pin

piston boss. Install nut loosely on main screw and place assembly on a press. Press piston pin out of connecting rod. Remove tool from piston.

Installation — 1) Lubricate piston pin holes in piston and connecting rod and use suitable tool to install pin. Install spring inside pilot and install spring and pilot in the anvil. Install piston pin over main screw.

2) Place piston (with notch up) and connecting rod over pilot so pilot extends through piston pin holes. Assemble rods to pistons of the right cylinder bank (2, 4, 6 and 8) with indent on piston head opposite to larger chamfer on large bore end of connecting rod. Assemble rods to pistons of the left cylinder bank (1, 3, 5 and 7) with indent on piston head on the same side as the large chamfer on large bore end of connecting rod.

3) Install main screw and piston pin in piston and install nut on main screw to hold assembly together. Place assembly in a vise. Press piston pin in until piston pin bottoms on the pilot.

Checking Pin Fit — Assemble suitable tool in same manner as for piston pin removal and place assembly in a vise. Attach a torque wrench to nut and test torque to 15 ft. lbs. If connecting rod moves downward on piston pin, reject connecting rod and piston pin combination. Install a new connecting rod and recheck. If connecting rod does not move under 15 ft. lbs. torque, piston pin fit is satisfactory.

CRANKSHAFT MAIN & CONNECTING ROD BEARINGS

Engine	MAIN BEARINGS				CONNECTING ROD BEARINGS		
	Journal Diam.	Clearance	Thrust Bearing	Crankshaft End Play	Journal Diam.	Clearance	Side Play
400"	2.6245-2.6255"	.0005-.0020"	3	.002-.009"	2.375-2.376"	.0005-.0030"①	.009-.017"
440"-1	2.7495-2.7505"	.0005-.0020"	3	.002-.009"	2.375-2.376"	.0005-.0030"	.009-.017"
440"-3	2.7495-2.7505"	.0005-.0020"	3	.002-.007"	2.374-2.375"	.0010-.0025"	.009-.017"

① — Specification given is for 4-Bbl. carburetor models; 2-Bbl. model specification is .0005-.0025".

MAIN & CONNECTING ROD BEARINGS

NOTE — Plastigage method for checking bearing clearances may be used in place of Shim Stock Method. The following procedures are with oil pan and oil pump removed.

Connecting Rod Bearings — 1) After ensuring rod caps are marked for cylinder identification, remove rod caps. Smooth edges of a ½" by ¾" piece of brass shim stock .001" thick. Oil and place shim stock between bearing and connecting rod journal. Install bearing cap and tighten. Rotate crankshaft ¼ turn in each direction (Shim Stock Method for checking clearances). If a slight drag is felt, clearance is within limits. If no drag is felt, clearance is excessive. If crankshaft cannot be rotated, clearance is not enough.

2) New bearings are available in standard, .001", .002", .003", .010" and .012" undersize. Always install bearings in pairs. Do not use a new bearing with an old bearing. Install connecting rod bearings so formed tang fits into machined groove in connecting rod. Install rod caps, with "V" groove of bearing matching "V" groove of cap, and tighten nuts.

Main Bearings — 1) Use Shim Stock Method (thickness of shim .001") and check main bearing clearances, one at a time while all other main bearing caps are tight. New bearings are available in standard, .001", .002", .003", .010" and .012" undersize. A new .001" bearing may be used in combination with a new standard bearing or a .002" with a .001".
NOTE — Always use smaller diameter bearing as upper bearing on journal and do NOT use a new bearing in combination with an old bearing. Bearings must be replaced in pairs.

2) New lower main bearings, numbers 1, 2, 4 and 5, are interchangeable. New upper main bearings, numbers 2, 4 and 5, are also interchangeable. **NOTE** — Upper and lower bearings are NOT interchangeable with each other. Number 1 upper main bearing is NOT interchangeable and is chamfered on tab side for timing chain oiling and can be identified by a red marking on edge of bearing. Number 3 upper and lower main bearings are the thrust bearings and are not interchangeable with any other bearings (see illustration).

3) If bearing clearances are not within limits, remove bearing cap, insert suitable tool (C-3059) in oil hole of crankshaft journal and rotate crankshaft clockwise to remove upper bearing.

400" & 440" V8 ENGINE (Cont.)

To install new bearing, slightly chamfer sharp edges from plain side and start bearing in place. Install tool and slowly rotate crankshaft counterclockwise, sliding bearing in place. Install main bearing cap with new bearing installed and tighten. Check crankshaft end play and if not within specifications, replace number 3 upper and lower main bearings.

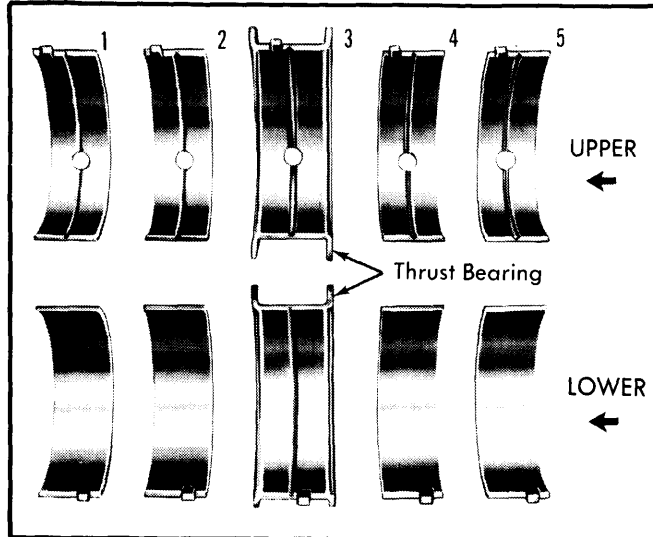

Fig. 11 Main Bearing Identification Showing Location of Thrust Bearing

REAR MAIN BEARING OIL SEAL

New split rubber type seals may be used for replacement without removing crankshaft. New type must be installed as paired upper and lower seals and cannot be used in combination with rope type seals. A rope type seal is supplied with engine gasket package to be used when engine is rebuilt or crankshaft is removed.

Removal W/Crankshaft Installed — With oil pan removed, remove rear seal retainer and rear main bearing cap. Remove lower rope seal from cap by prying from the side using a small screwdriver. Remove upper rope seal by turning suitable tool (C-4148) into end of seal and pulling seal out with tool while turning crankshaft. **CAUTION** — Do not damage crankshaft with tool during removal procedure.

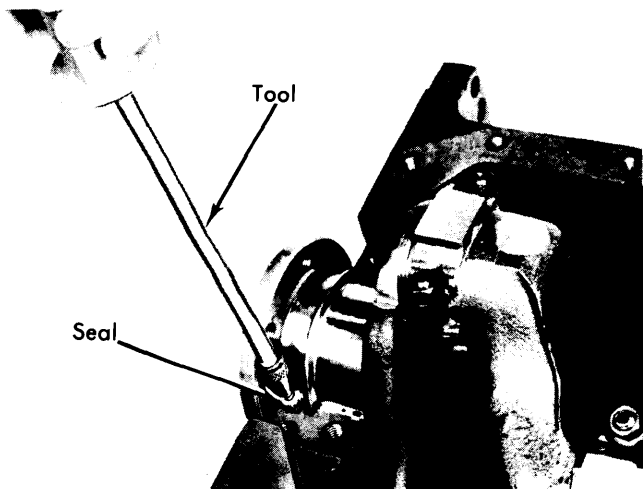

Fig. 12 Correct Procedure to Remove Upper Oil Seal

Installation — Wipe crankshaft surface clean and oil lightly before installing a new seal. Oil seal lip lightly with engine oil. Hold seal (with paint stripe to rear) tightly against crankshaft with thumb and rotate crankshaft, if necessary, while sliding seal into groove. **CAUTION** — Care must be exercised so sharp edge of groove does not shave or nick the back of seal. Install other half of seal into lower seal retainer with paint stripe to rear. Install rear main bearing cap and tighten bolts. **NOTE** — Do not use sealer or cement on seal ends or lips.

Installation W/Crankshaft Removed — Install a new oil seal (rope type) in cylinder block and in seal retainer so that both ends protrude. Tap seal into position on cylinder block using suitable tool (C-3635 or C-3743) with bridge removed until tool is seated in bearing bore. Install bridge on tool and tap seal into position in rear main bearing cap until tool is seated. Holding tool in position, trim off portion of seal which protrudes above the cylinder block and bearing cap.

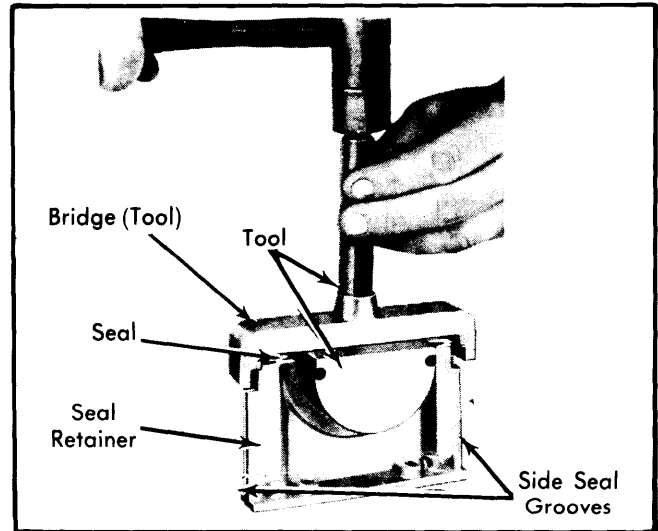

Fig. 13 Correct Procedure to Install Lower Oil Seal

Side Seals Installation — **NOTE** — Following operations must be performed as rapidly as possible because seals are made from material which expands rapidly when oiled. Apply mineral spirits or diesel fuel to side seals. Install seals immediately in seal retainer grooves. Install seal retainer and tighten screws. Failure to pre-oil seals will result in probable oil leak.

ENGINE FRONT COVER

Removal — Drain cooling system, disconnect radiator hoses and remove radiator. Remove water pump assembly. Remove crankshaft vibration damper attaching bolt. Remove two of the pulley bolts, install suitable tool (C-3688) and remove damper assembly from end of crankshaft. Remove front cover attaching bolts, front cover and gasket.

Installation — Check that mating surfaces of front cover and cylinder block are clean and free from burrs. Install new gasket and engine front cover over locating dowels. Install and tighten front cover attaching bolts. Lubricate front cover seal lip with Lubriplate, position vibration damper hub slot on key in crankshaft and slide hub onto crankshaft. Position suitable installing tool (part of C-3688) and press vibration damper assembly on crankshaft. Install damper retaining washer and bolt. Install drive belt pulley, water pump assembly and radiator. Adjust drive belt tension and fill cooling system.

400" & 440" V8 ENGINE (Cont.)

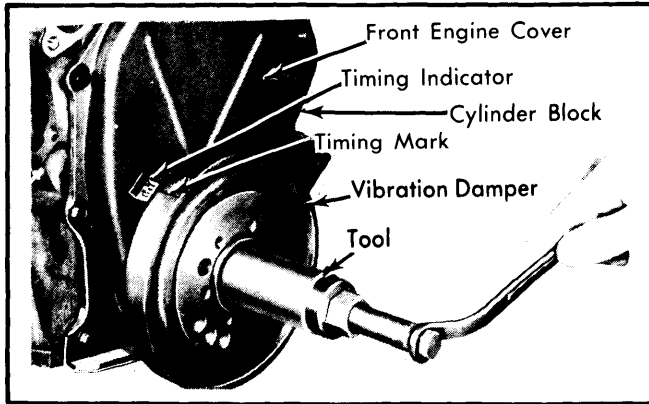

Fig. 14 Correct Procedure to Install Vibration Damper

FRONT COVER OIL SEAL

Removal — With front cover removed, use a drift and hammer to lightly tap at several positions around seal case to deform seal inward. **CAUTION** — Support front cover at seal area to prevent deforming front cover. Using vise grips, twist and pull seal at several positions to remove seal from cover.

Installation — Use a suitable tool (C-3506) to press seal into front cover. **NOTE** — Lip of the seal must be toward rear of engine. Seal is properly installed when neoprene is tight against face of cover. A .0015" feeler gauge should not be able to enter between neoprene face and cover (see illustration).

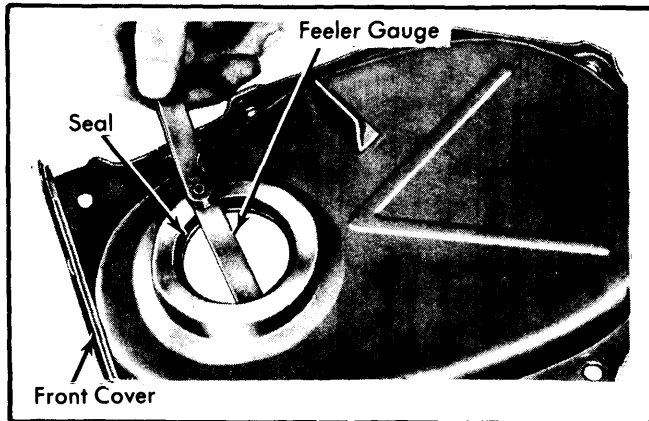

Fig. 15 Using Feeler Gauge to Check Front Cover Seal Installation

CAMSHAFT			
Engine	Journal Diam.	Clearance	Lobe Lift
All		.001-.005"
No. 1	1.998-1.999"		
No. 2	1.982-1.983"		
No. 3	1.967-1.968"		
No. 4	1.951-1.952"		
No. 5	1.748-1.749"		

TIMING CHAIN

Checking For Stretch — Position scale next to timing chain (see illustration) to measure any movement of the chain. Place torque wrench with socket over camshaft sprocket lock bolt and apply torque in direction of crankshaft rotation to remove

slack. Torque should be 30 ft. lbs. with cylinder heads installed or 15 ft. lbs. with cylinder heads removed. **NOTE** — Do not permit the crankshaft to move. Apply same torque in reverse direction and measure amount of chain movement. If movement exceeds 1/8", install a new timing chain.

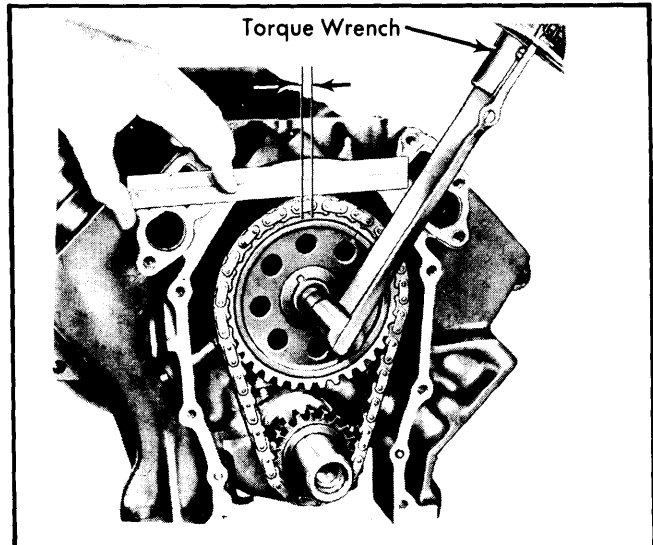

Fig. 16 Measuring Timing Chain Stretch

Removal — With front cover removed, remove camshaft sprocket attaching bolt and washer. Remove timing chain with crankshaft and camshaft sprockets.

Installation — When installing timing chain, use a suitable tool (C-3509) to prevent camshaft from contacting welch plug in rear of engine block. Remove distributor and oil pump-distributor drive gear. Locate tool against rear side of cam gear and attach tool with distributor retainer plate bolt. Then proceed as follows:

1) Place camshaft and crankshaft sprockets on bench with timing marks on an imaginary centerline through bore of both sprockets. Place timing chain around both sprockets. Turn crankshaft and camshaft to line up with keyway location in sprockets.

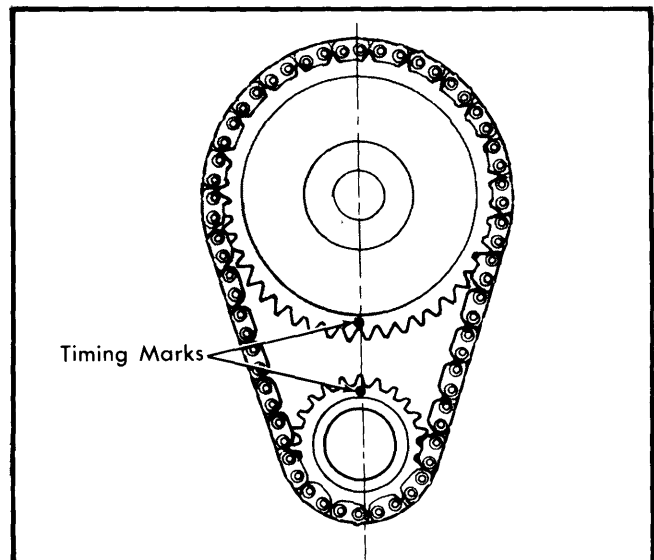

Fig. 17 Timing Chain Sprocket Alignment

400" & 440" V8 ENGINE (Cont.)

2) Slide both sprockets evenly over their respective shafts (with new chain installed on sprockets). Use a straightedge to measure alignment of timing marks. Install camshaft attaching bolt and washer. Tighten bolt and slide crankshaft oil slinger over shaft and up against sprocket (flange away from sprocket).

CAMSHAFT

NOTE — Whenever a new camshaft is installed inspect and check, with a straightedge, all tappet faces for "dishing". Replace any tappet with a negative crown.

Removal — Remove intake manifold and rocker arm covers. Remove rocker arm and shaft assemblies. Remove push rods and tappets. **NOTE** — Identify push rods and tappets for reinstallation in original location. Remove distributor and lift out oil pump-distributor drive shaft. Remove fuel pump and allow fuel pump push rod to drop away from cam eccentric. Remove timing chain and sprockets. Remove camshaft taking care not to damage camshaft bearings with camshaft lobes.

Installation — Lubricate camshaft lobes and bearing journals. Insert camshaft to within 2" of its final position in block. Install suitable tool (C-3509) in distributor drive hole and hold in position using distributor retainer plate bolt. **NOTE** — Tool must be modified by grinding off index lug holding upper arm on tool and then rotate arm 180°. Install camshaft to final position. Install timing chain and sprockets, fuel pump and rod. Install oil pump-distributor drive shaft and distributor (see Distributor Timing & Installation). Reverse removal procedure for remaining components.

CAMSHAFT BEARINGS

Removal — With engine completely disassembled, drive out rear cam bearing welch plug. Install proper size adapters and horse shoe washers (C-3132A) at rear of each bearing to be removed and drive out bearings.

Installation — 1) Place new camshaft bearing over proper adapter and position bearing in tool. Install horse shoe lock and by reversing removal procedure, drive bearing into place. Install remaining bearings in same manner. **NOTE** — Install No. 1 bearing $\frac{1}{32}$ " inward from front face of cylinder block.

2) Bearing index must be inspected after installation by inserting a pencil flashlight in bearing. Bearing oil hole must be aligned with drilled oil passage from main bearing. Other oil

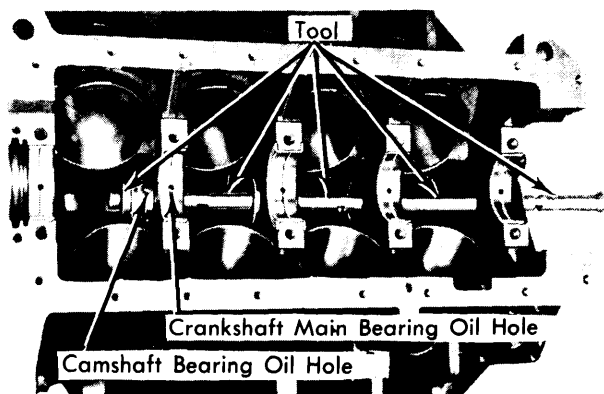

Fig. 18 Correct Procedure to Remove Camshaft Bearings

holes in bearing should be visible by looking down on left bank oil hole above and between No. 6 and No. 8 cylinders to No. 4 camshaft bearing. On right bank, look down on oil hole between and above No. 5 and No. 7 cylinders to No. 4 camshaft bearing. If bearing oil holes are not in exact alignment, remove and reinstall correctly. Install new welch plug squarely in hole at rear of camshaft.

DISTRIBUTOR TIMING & INSTALLATION

Distributor Timing — Before installing distributor-oil pump drive shaft, time engine as follows: Rotate crankshaft so number one cylinder is at top dead center on the firing stroke (both valves closed). Straight line on vibration damper should be under "O" on timing indicator. Coat shaft and drive gear with engine oil. Install shaft so that when gear spirals into place, it will index with oil pump shaft so slot in top of drive gear will be parallel with center line of crankshaft (see illustration).

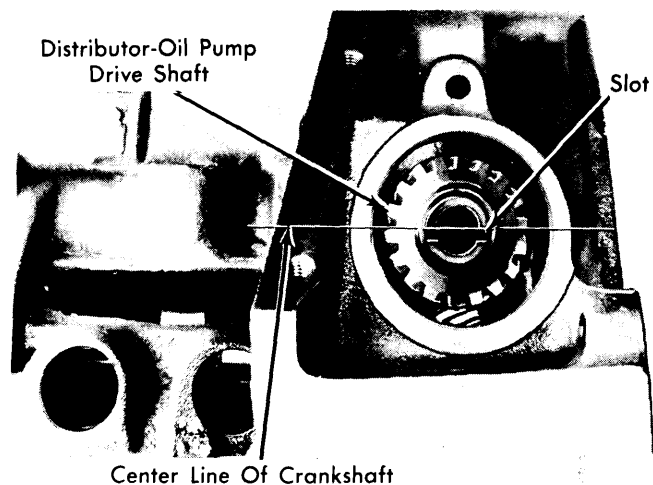

Fig. 19 Distributor Drive Gear Slot Alignment

Distributor Installation — Hold distributor over mounting pad of cylinder block with vacuum chamber pointing toward center of engine. Turn rotor to point forward and approximately toward location of number one terminal in distributor cap. Place distributor gasket in position, lower distributor and engage shaft in slot of distributor drive shaft gear. Turn distributor in direction of distributor shaft rotation until breaker points are just separating and install hold down clamp.

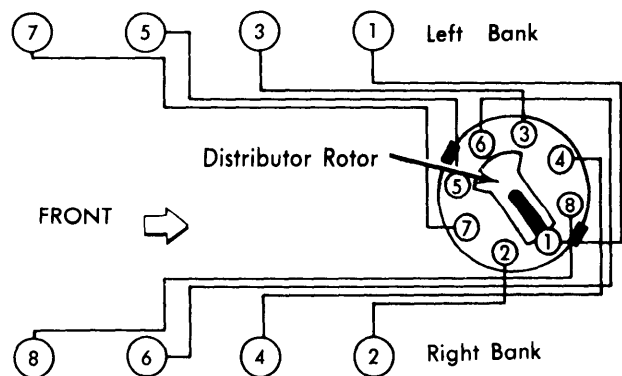

Fig. 20 Schematic Showing Distributor Wire Routing & Timing

400" & 440" V8 ENGINE (Cont.)

ENGINE OILING

Crankcase Capacity — 400" and 440"-1 require 5 quarts. 440"-3 requires 6 quarts. On all engines, add 1 quart with filter change.

Oil Filter — Change at first oil change and every second oil change after that.

Pressure Regulator Valve — In oil pump. Not adjustable.

Normal Oil Pressure (Hot) — Pressure should be 30-80 psi at 2000 RPM.

ENGINE OILING SYSTEM

See illustration. Force feed type using rotor type pump and full flow oil filter. Oil is supplied to hollow rocker arm shaft through indexed holes in No. 4 camshaft bearing. Drilled holes in rocker shaft supply oil to rocker arms which supply lubrication to push rods and valve assemblies. Holes in main oil galleries supply oil to valve lifters.

OIL PUMP

Disassemble (see illustration), clean and inspect all parts for proper clearances (see specifications). **NOTE** — Inner rotor and shaft assembly can only be replaced if outer rotor is replaced as units are a matched assembly.

Oil Pump Replacement Specifications

Pump Cover Wear0015" or More
Inner Rotor Thickness942" or Less
Outer Rotor Thickness943" or Less
Outer Rotor Diameter	2.469" or Less
Clearance Over Rotors004" or More
Outer Rotor-to-Pump Body014" or More
Tip Clearance Between Rotors010" or More

Pressure Relief Valve Spring — Spring has free length of 2 $\frac{1}{4}$ " and should test at 22.3-23.3 lbs. when compressed to 1 $\frac{1}{32}$ ".

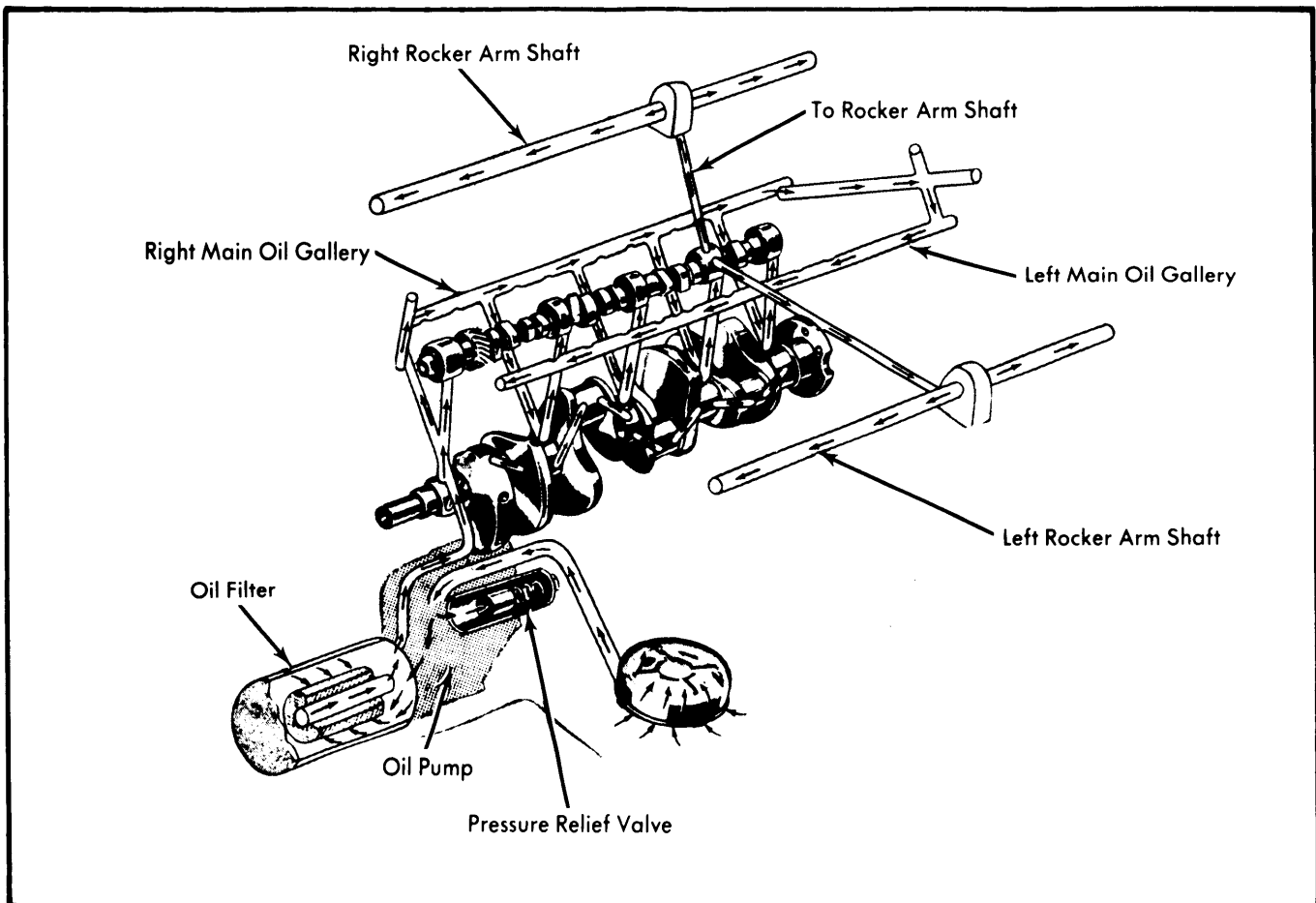

Fig. 21 Schematic of Engine Oiling System

Chrysler Corp. V8 Engines

400" & 440" V8 ENGINE (Cont.)

ENGINE OILING (Cont.)

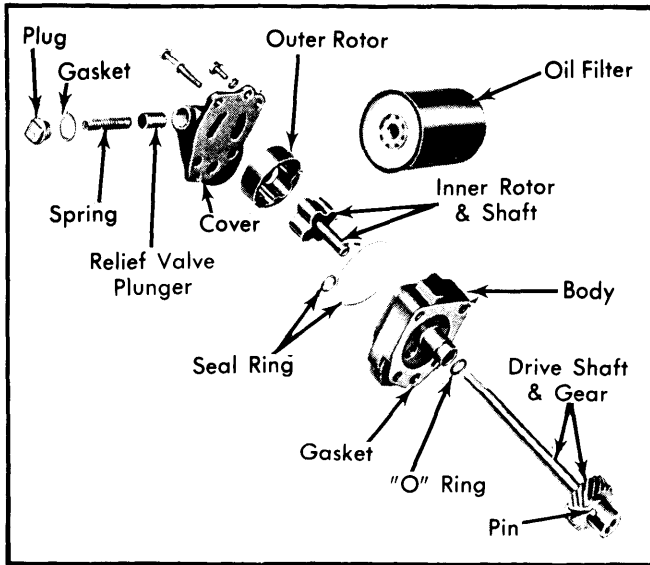

Fig. 22 Exploded View of Typical Oil Pump Assembly

TIGHTENING SPECIFICATIONS

Application	Ft. Lbs.
Camshaft Lock Bolt	50
Connecting Rod Cap	45
Crankshaft Main Bearing	85
Crankshaft Damper Bolt	135
Cylinder Head Bolt	70
Exhaust Manifold	30
Flywheel-to-Crankshaft	55
Flywheel Housing-to-Cylinder Block	50
Front Cover	
" Bolt	17
3/8" Bolt	40
Intake Manifold	45
Oil Pan	17
Oil Pump	30
Rear Main Bearing Side Seals	25
Rocker Arm Cover	3.5
Rocker Arm Shaft Bolts	25
Vibration Damper Pulley	17
Water Pump	30