

# Chrysler Corp. V8 Engines

## 318" & 360" V8 ENGINES

GENERAL SPECIFICATIONS							
Year	Displ. Cu. Ins.	Carburetor	HP at RPM	Torque (Ft. Lbs. at RPM)	Compr. Ratio	Bore	Stroke
1976	318"	2-Bbl.	.....	.....	8.6:1	3.91"	3.312"
	360"	2-Bbl.	.....	.....	8.4:1	4.0"	3.58"
	360-3"	2-Bbl.	.....	.....	8.4:1	4.0"	3.58"

### ENGINE IDENTIFICATION

Engine identification number is stamped on left front of block below cylinder head. First five digits contain engine cubic inch displacement. **NOTE** - 360-3" engines are designated by the numeral "3" stamped below engine number.

Application	Digits
318" .....	318
360" .....	360

### SPECIAL ENGINE MARKS

Information identifying special engine marks is stamped on the cylinder block after the serial number and is decoded as follows:

**Maltese Cross (⊗)** - .001" undersize crankshaft journals. "M" or "R", representing "main" or "rod" followed by the cylinder number of journals concerned, will be found stamped on a crankshaft counterweight.

**Maltese Cross (⊗) And "X"** - .010" undersize crankshaft journals. "M" or "R" will be found stamped on a crankshaft counterweight.

**"A"** - Indicates all cylinder bores .020" oversize.

**"♦"** - Indicates .008" oversize tappets.

**"O/S"** - Indicates .005" oversize valve stems.

### ENGINE REMOVAL

See *Engine Removal at end of Engine Section.*

### INTAKE MANIFOLD

**Removal** - Remove air cleaner and disconnect fuel line. Disconnect accelerator linkage, heater hose, by-pass hose and radiator hose. Disconnect coil wires and vacuum hose between carburetor and distributor. Remove intake manifold, coil and carburetor as an assembly.

**Installation** - 1) Coat both sides of intake manifold gaskets and side seals with suitable sealer. **NOTE** - Do not coat side composition gaskets on 360-3" engines. Install gaskets with end seals locked in tangs of head gasket. Place a drop of sealer in "V" notches of side gaskets after installation.

2) Position intake manifold on engine, inspect seals for correct positioning and install manifold attaching bolts. Tighten bolts in sequence, as shown in Fig. 1, using two steps to reach tightening specifications.

Application	Step 1 (Ft. Lbs.)	Step 2 (Ft. Lbs.)
All Engines.....	25	40

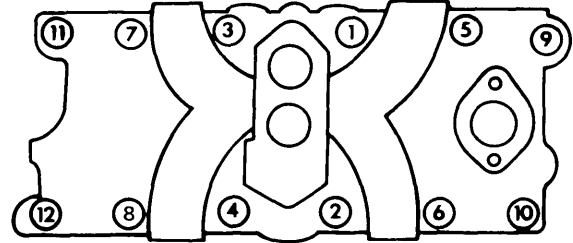

Fig. 1 Intake Manifold Tightening Sequence

### CYLINDER HEAD

**Removal** - 1) Drain cooling system and disconnect battery ground cable. Remove alternator, air cleaner, distributor wires and cap. Disconnect fuel line, accelerator linkage, vacuum control hose between carburetor and distributor, coil wires, and temperature sending unit wire. Disconnect heater hoses, by-pass hose and radiator hose.

2) Remove closed ventilation system, evaporation control system and rocker arm covers. Remove water by-pass tube between intake manifold and water pump (if equipped). Remove intake manifold, coil and carburetor as an assembly. Remove exhaust manifolds from cylinder heads.

3) Remove rocker arm shaft assemblies, then pull push rods from cylinder heads after identifying location for reinstallation in original positions. Remove attaching bolts and cylinder heads from engine.

**Installation** - Clean all gasket surfaces of cylinder block and head. Coat new gasket with suitable sealer. Install gasket and cylinder head on cylinder block. Install cylinder head bolts and tighten to specifications in two steps. Use tightening sequence shown in Fig. 2.

Application	Step 1 (Ft. Lbs.)	Step 2 (Ft. Lbs.)
All Engines.....	50	95

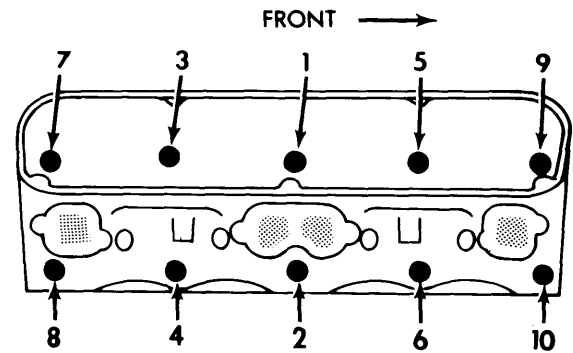

Fig. 2 Cylinder Head Tightening Sequence

## 318" & 360" V8 ENGINES (Cont.)

VALVES							
Engine & Valve	Head Diam.	Face Angle	Seat Angle	Seat Width	Stem Diameter	Stem Clearance	Valve Lift
318"							
Int.	1.78"	45°	45°	.065-.085"	.372-.373"	.001-.003"	.373"
Exh.	1.50"	43°	45°	.040-.060"	.371-.372"	.002-.004"	.400"
360"							
Int.	1.88"	45°	45°	.065-.085"	.372-.373"	.001-.003"	.410"
Exh.	1.60"	43°	45°	.040-.060"	.371-.372"	.002-.004"	.410"
360-3"							
Int.	1.816"	45°	45°	.080-.105"	.372-.373"	⓪.017"	.373"
Exh.	1.522"	45°	45°	.090-.110"	.371-.372"	⓪.017"	.400"

⓪ — Using the wobble method of measurement.

### VALVE ARRANGEMENT

E-I-I-E-E-I-I-E (Both banks, front to rear).

### VALVE GUIDE SERVICING

**Wear Check** — Remove valve springs and install suitable sleeve over valve stem and install valve in cylinder head. Attach suitable dial indicator to cylinder head and position indicator at a right angle to valve stem being measured. Total sideplay should be within specifications. If dial reading is excessive or stems are scuffed or scored, ream guides for installation of valves with oversize stems.

**Servicing** — Ream guides to next oversize valve stem if necessary. Oversize valve stems are available in .005", .015" and .030" oversize. **NOTE** — Do not attempt to ream guides from standard diameter to .030" oversize in one step. Use step procedure to obtain the .030".

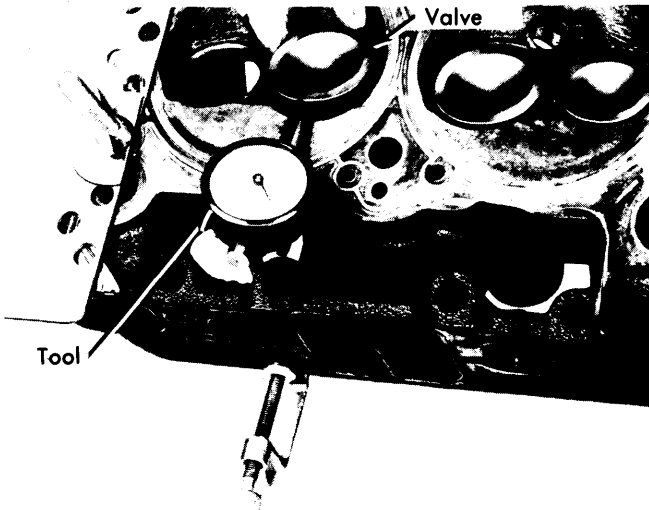

Fig. 3 Measuring Valve Stem to Guide Clearance

### VALVE STEM OIL SEALS

Cup type seal is used on all valves. Long seal is used on intake valve and short seal is used on exhaust valve. If seals are removed for any reason, new seals must be used upon assembly.

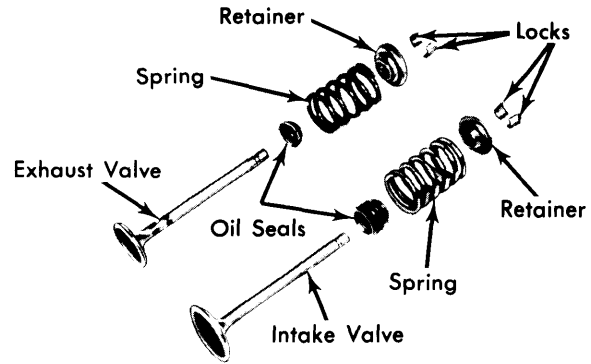

Fig. 4 Exploded View of Valve Assemblies

VALVE SPRINGS			
Engine	Free Length	PRESSURE (LBS.)	
		Valve Closed	Valve Open
318"			
Int.	2.00"	78-88@1 <sup>1</sup> / <sub>16</sub> "	170-184@1 <sup>5</sup> / <sub>16</sub> "
Exh.	2.00"	78-88@1 <sup>1</sup> / <sub>16</sub> "	170-184@1 <sup>5</sup> / <sub>16</sub> "
360"			
Int.	2.00"	101-111@1 <sup>1</sup> / <sub>16</sub> "	177-188@1 <sup>5</sup> / <sub>16</sub> "
Exh.	2.00"	101-111@1 <sup>1</sup> / <sub>16</sub> "	177-188@1 <sup>5</sup> / <sub>16</sub> "
360-3"			
Int.	2.00"	78-88@1 <sup>1</sup> / <sub>16</sub> "	170-184@1 <sup>5</sup> / <sub>16</sub> "
Exh.	1 <sup>1</sup> / <sub>16</sub> "	78-88@1 <sup>1</sup> / <sub>16</sub> "	170-184@1 <sup>5</sup> / <sub>16</sub> "

### VALVE SPRINGS

**Removal** — With cylinder head removed, compress valve springs using a suitable tool (C-3422A). Remove valve retaining locks, valve spring retainers, rotators (if equipped), valve springs and valve stem cup seals. **NOTE** — Remove any burrs from valve stem lock grooves to prevent damage to valve guide if valves are removed.

**Inspection** — Whenever valve springs have been removed, they must be tested. Using a suitable tester, valve springs must be within specifications. Replace springs which do not meet specifications. Inspect each valve spring for squareness using a steel square and surface plate. If spring is more than <sup>1</sup>/<sub>16</sub>" out-of-square, a new spring must be installed.

## 318" & 360" V8 ENGINES (Cont.)

**Installation** — Coat valve stems with lubricant and position in cylinder head. If valve or seats have been reground, check valve stem height using a suitable go-no go gauge. If valve is too long, grind material off valve stem tip until length is within limits. **NOTE** — Do not grind tips on 360-3" exhaust valves. Replace if not within limits. Install new oil seals on all valves, reinstall valve springs and retainers. Use spring compressor to compress springs, then install valve locks.

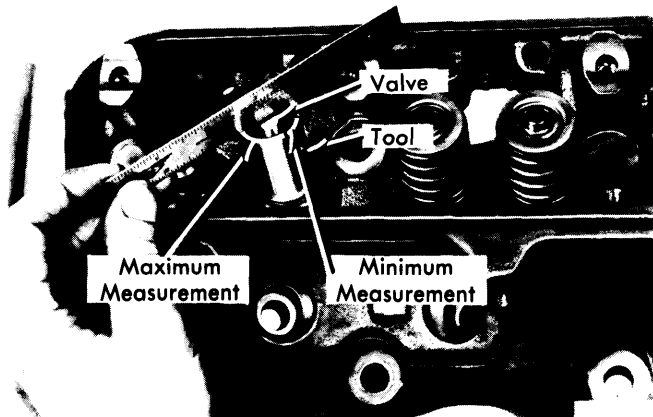

Fig. 5 Measuring Valve Stem Length

### VALVE SPRING INSTALLED HEIGHT

If valves and/or seats are reground, measure installed height of springs. Measurement is taken from bottom of spring seat in cylinder head to bottom surface of spring retainer. **NOTE** — If spacers are installed, measure from top of spacer. If installed height is not within specifications, install a  $\frac{1}{16}$ " spacer at head counterbore to correct spring height. **CAUTION** — Do not shim to a height less than specifications.

#### Valve Spring Installed Height

Application	Height
All W/O Rotators .....	$1\frac{5}{8}$ - $1\frac{1}{16}$ "
All W/Rotators .....	$1\frac{15}{32}$ - $1\frac{1}{32}$ "

### ROCKER ARM ASSEMBLY

Rocker arms are stamped steel type; arms are mounted on shaft attached to cylinder head at five support brackets which

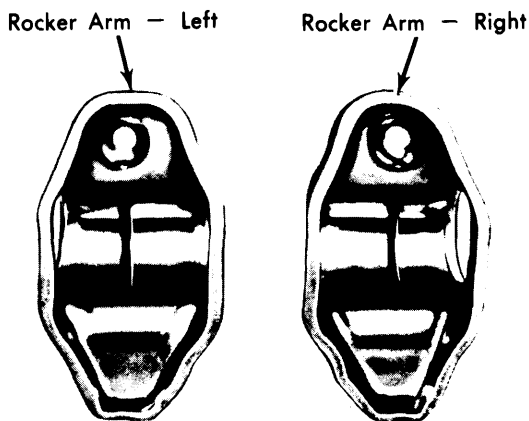

Fig. 6 Rocker Arm Identification

are cast into cylinder head. Rocker arms have right and left positions (see Fig. 6). If rocker arm assemblies were disassembled, reassemble with rocker arms in correct position on shaft (see Fig. 7).

Install rocker arms and shaft to engine while noting the following: Notch on end of rocker arm shaft must point to centerline of engine and toward engine front on left hand bank, or to rear of engine on right hand bank. Long, stamped retainers must be in number two and number four positions.

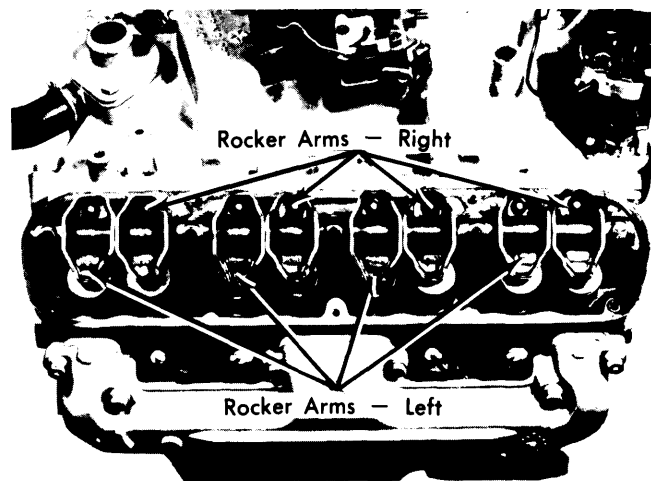

Fig. 7 Rocker Arm Location on Rocker Arm Shaft

### HYDRAULIC VALVE LIFTER ASSEMBLY

**NOTE** — Lifters are serviced as complete assemblies only. Parts are not interchangeable between lifters. If any component of lifter is worn or damaged, complete lifter must be replaced.

To test, remove cap from plunger (see Fig. 8) and plunger from tappet body. Fill tappet body with clean kerosene and install plunger and cap. Place lifter upright in Lifter Testing Pliers and check leak down. If lifter collapses immediately, disassemble, clean and retest. If rapid leak down still occurs, replace lifters. Use a straightedge to check all tappets for a negative crown. If a negative crown (dish) is observed, tappet must be replaced.

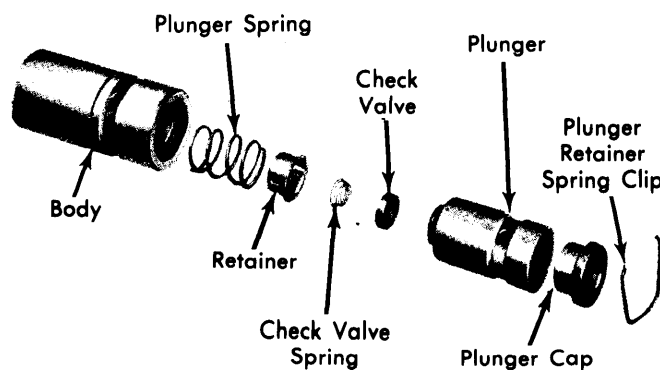

Fig. 8 Exploded View of a Typical Hydraulic Lifter Assembly

## 318" & 360" V8 ENGINES (Cont.)

PISTONS, PINS, RINGS						
Engine	PISTONS	PINS		RINGS		
	Clearance	Piston Fit	Rod Fit	Rings	End Gap	Side Clearance
318"	.0005-.0015"	0.0-.0005"	.0007-.0014"	1 & 2 3	.010-.020" .015-.055"	.0015-.0030" .0002-.0050"
360"	.0005-.0015"	.00025-.00075"	.0007-.0014"	1 & 2 3	.010-.020" .015-.055"	.0015-.0030" .0002-.0050"
360-3"	.0005-.0015"	.00025-.00075"	.007-.0014"	1 & 2 3	.010-.020" .015-.055"	.0015-.0030" .0002-.0050"

### OIL PAN

See *Oil Pan Removal at end of Engine Section.*

### PISTON & ROD ASSEMBLY

**NOTE** — Following procedures are with cylinder head and oil pan removed.

**Removal** — Remove ridge at top of cylinder bores using suitable tool before removing pistons from block. **NOTE** — Keep tops of pistons covered during this procedure. Rotate crankshaft and inspect connecting rods and rod caps for cylinder identification. Identify them if necessary. Remove rod cap and push each piston and rod assembly out top of cylinder bore being careful not to nick crankshaft journals. Install rod caps on mating rods.

**Installation** — 1) Before installing piston and connecting rod assemblies into cylinder block, compression ring gaps must be staggered so neither is in line with oil ring rail gaps and "TOP" must be facing top of piston. Oil ring expander ends should be positioned under the notch on piston. Oil ring rail gaps should be facing middle of engine upon installation and spread 3" apart (see Fig. 9).

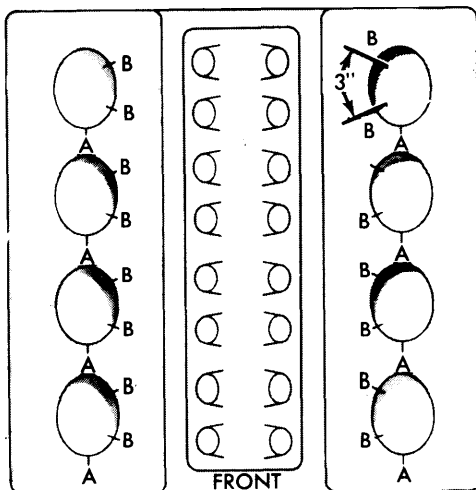

TOP VIEW OF BLOCK

A — Expander Gaps

B — Rail Gaps

Fig. 9 Positioning Oil Rings for Installation

2) Immerse piston head and rings in clean engine oil and slide suitable ring compressor over piston and tighten. **NOTE** — Do not allow position of rings to change during ring compressor installation and tightening.

3) Rotate crankshaft so connecting rod journal is on center of cylinder bore. Insert rod and piston assembly into cylinder bore and guide rod over the crankshaft journal, taking care not to nick the journal. **NOTE** — Notch on top of piston must face front of engine and larger chamfer of connecting rod bore must be installed toward crankshaft journal fillet.

4) Tap piston into cylinder bore using wooden handle of a hammer and guide connecting rod into place on crankshaft journal. Install rod cap and tighten. Repeat procedure for each piston assembly.

### FITTING PISTONS

Pistons should be measured 90° to piston pin axis at top of skirt. Measure cylinder bore halfway down the bore 90° to crankshaft center line. Pistons and cylinder bores should be measured at normal room temperature, 70°F.

### PISTON PINS

**Removal** — Use suitable tool for piston pin removal as follows: Install pilot on main screw (see Fig. 10) and install screw through piston pin. Install anvil (with spring removed) over threaded end of main screw with small end of anvil against piston boss. Install nut loosely on main screw and place assembly on a press. Press piston pin out of connecting rod. Remove tool from piston.

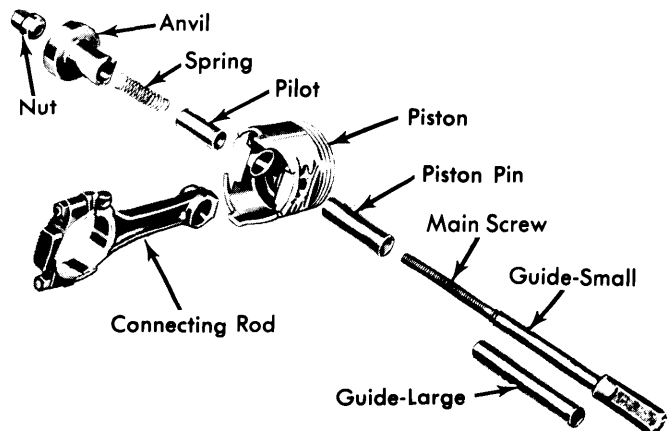

Fig. 10 Exploded View of Piston Pin Removal & Installation Tool

## 318" &amp; 360" V8 ENGINES (Cont.)

**Installation** — 1) Lubricate piston pin holes in piston and connecting rod and use suitable tool to install pin. Install tool spring inside pilot and install spring and pilot in the anvil. Install piston pin over main screw.

2) Place piston (with notch up) and connecting rod over pilot so pilot extends through piston pin holes. Assemble rods to pistons of the right cylinder bank (2,4,6 and 8) with indent on piston head opposite to larger chamfer on large bore end of connecting rod. Assemble rods to pistons of the left cylinder bank (1,3,5 and 7) with indent on piston head on the same side as the large chamfer on large bore end of connecting rod.

3) Install main screw and piston pin in piston and install nut on main screw to hold assembly together. Place assembly in a vise. Press piston pin in until piston pin bottoms on the pilot.

**Checking Pin Fit** — Assemble suitable tool in same manner as for piston pin removal and place assembly in a vise. Attach a torque wrench to nut and test torque to 15 ft. lbs. If connecting rod moves downward on piston pin, reject connecting rod and piston pin combination. Install a new connecting rod and recheck. If connecting rod does not move under 15 ft. lbs. torque, piston pin fit is satisfactory.

CRANKSHAFT MAIN & CONNECTING ROD BEARINGS							
Engine	MAIN BEARINGS				CONNECTING ROD BEARINGS		
	Journal Diam.	Clearance	Thrust Bearing	Crankshaft End Play	Journal Diam.	Clearance	Side Play
318"	2.4995-2.5005"	.0005-.0020"	3	.002-.009"	2.124-2.125"	.0005-.0025"	.006-.014"
360"	2.8095-2.8105"	.0005-.0020"	3	.002-.009"	2.124-2.125"	.0005-.0025"	.006-.014"
360-3	2.8095-2.8105"	.0005-.0020"	3	.002-.007"	2.14-2.125"	.0005-.0025"	.006-.014"

## MAIN &amp; CONNECTING ROD BEARINGS

**NOTE** — Plastigage method for checking bearing clearances may be used in place of Shim Stock Method. The following procedures are with oil pan and oil pump removed.

**Connecting Rod Bearings** — 1) After ensuring rod caps are marked for cylinder identification, remove rod caps. Smooth edges of a  $\frac{1}{2}$ " by  $\frac{3}{4}$ " piece of brass shim stock .001" thick. Oil and place between bearing and connecting rod journal. Install bearing cap and tighten. Rotate crankshaft  $\frac{1}{4}$  turn in each direction (Shim Stock Method for checking clearances). If a slight drag is felt, clearance is within limits. If no drag is felt, clearance is excessive. If crankshaft cannot be rotated, clearance is not enough.

2) New bearings are available in standard, .001", .002", .003", .010" and .012" undersize. Always install bearings in pairs. Do not use a new bearing with an old bearing. Install connecting rod bearings so formed tang fits into machined groove in connecting rod. Install rod caps, with "V" groove of bearing matching "V" groove of cap, and tighten nuts.

**Main Bearings** — 1) Use Shim Stock Method (thickness of shim .001") and check main bearing clearances, one at a time while all other main bearing caps are tight. New bearings are available in standard, .001", .002", .003", .010" and .012" undersize. A new .001" bearing may be used in combination with a new standard bearing or a .002" with a .001". **NOTE** — Always use smaller diameter bearing as upper bearing on journal.

2) If bearing clearances are not within limits, remove bearing cap, insert suitable tool (C-3509) in oil hole journal and rotate crankshaft clockwise to remove upper bearing. To install new upper bearing, slightly chamfer sharp edges from plain side and start bearing in place. Insert tool and slowly rotate crankshaft counterclockwise, sliding bearing in place. Install main bearing cap with new bearing installed and tighten. **NOTE** — Upper main bearings are grooved and lower main bearings are plain. Upper and lower are not interchangeable.

3) Check crankshaft end play and if not within specifications, change number three main bearing. This bearing carries thrust load.

## REAR MAIN BEARING OIL SEAL

New split rubber type seals may be used for replacement without removing crankshaft. New type must be installed as paired upper and lower seals and cannot be used or combined with old type rope seals.

**Removal W/Crankshaft Installed** — With oil pan removed, remove rear seal retainer and rear main bearing cap. Remove upper seal by turning suitable tool (C-4148) into end of seal and pulling seal out with tool (do not mar crankshaft). Remove lower seal by carefully prying from the side with small screwdriver.

**Installation** — Oil upper seal lip lightly with engine oil. Hold seal (with paint stripe to rear) tightly against crankshaft with a thumb and rotate crankshaft while sliding seal into groove. **CAUTION** — Sharp edge of groove in block may shave or nick back of seal. Care must be exercised not to damage sealing lip. Install lower half of seal into lower seal retainer with paint stripe to rear. Install main bearing cap and tighten. Install lower seal retainer and tighten.

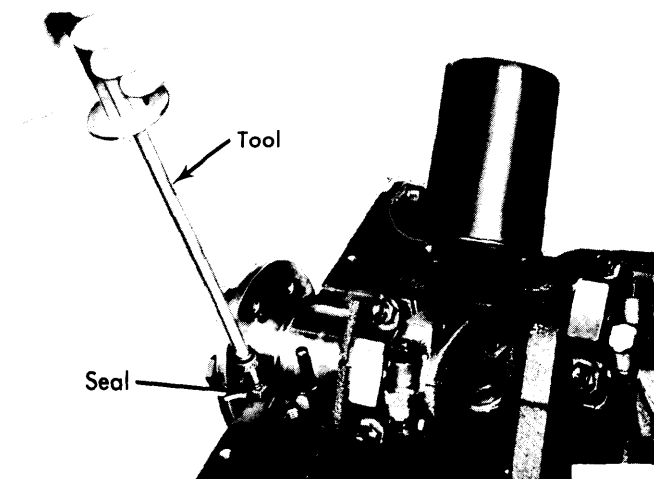

Fig. 11 Removing Upper Rear Main Oil Seal

## 318" & 360" V8 ENGINES (Cont.)

### Installation W/Crankshaft Removed (318" Engine Only)

— Install new rope seal in bearing cap and cylinder block so that both ends protrude. Use a suitable tool (C-3511 or equivalent) to tap seal into position until tool is seated in bearing bore. Hold tool in position and cut off portion of seal which extends beyond block or bearing cap.

### ENGINE FRONT COVER

**Removal** — 1) Drain cooling system and remove radiator and water pump assembly. Remove power steering pump (if equipped). Remove pulley from vibration damper. Remove bolt and washer securing vibration damper on crankshaft. Using suitable tool (C-3688), remove damper from end of crankshaft.

2) Remove fuel lines and fuel pump. Loosen oil pan bolts and remove front bolt at each side. Remove cover attaching bolts, cover and gasket using care not to damage oil pan gasket. **NOTE** — It is normal to find neoprene particles collected between crankshaft seal retainer and oil slinger.

**Installation** — Check that mating surfaces of cover and cylinder block are clean and free from burrs. Lubricate seal lip with Lubriplate and install cover with new gasket. Install attaching bolts and tighten. Tighten oil pan bolts and install fuel pump, lines and power steering pump. Install vibration damper, water pump assembly and radiator. Fill cooling system and adjust drive belt tension.

### FRONT COVER OIL SEAL

**Removal** — With front cover removed, use a drift and hammer to tap lightly around seal case to form oil seal case inward. Grasp seal case with vise grips; twist and pull at several positions on seal case to remove seal from cover.

**Installation** — Using suitable tool (C-3506), insert installing screw through the installing plate. Insert screw with plate through seal opening (with inside of cover facing up) and place seal in position with seal lips down. Place seal installing plate into seal with protective recess toward lip of seal retainer. Install flat washer and nut on installing screw. Hold screw and tighten nut. Seal is properly installed when seal case is tight against face of cover. If a .0015" feeler gauge cannot be inserted between neoprene and cover, seal is properly installed.

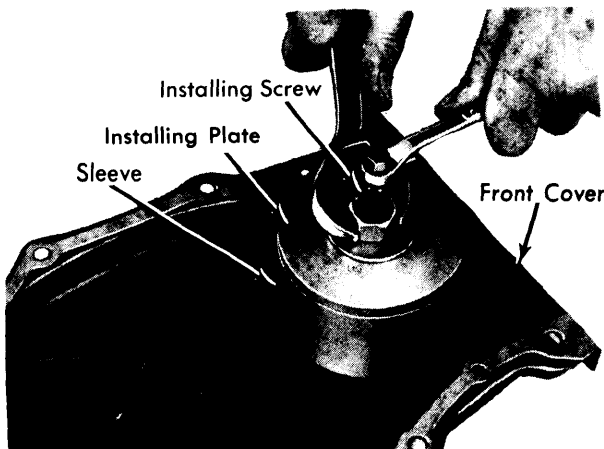

Fig. 12 Installing Front Cover Oil Seal

CAMSHAFT			
Engine	Journal Diam.	Clearance ①	Lobe Lift
318" & 360"	No. 1 1.998"	.001-.005"	.....
	No. 2 1.982"		
	No. 3 1.967"		
	No. 4 1.951"		
	No. 5 1.561"		

① — End play is .002-.010"

### TIMING CHAIN

**Checking For Stretch** — Position scale next to timing chain (see illustration) to measure any movement of chain. Place torque wrench with socket over camshaft sprocket lock bolt and apply torque in direction of crankshaft rotation to remove slack. Torque should be 30 ft. lbs. with cylinder heads installed or 15 ft. lbs. with cylinder heads removed. **NOTE** — Do not permit the crankshaft to move. Apply same torque in reverse direction and measure amount of chain movement. If movement exceeds 1/8", install a new timing chain.

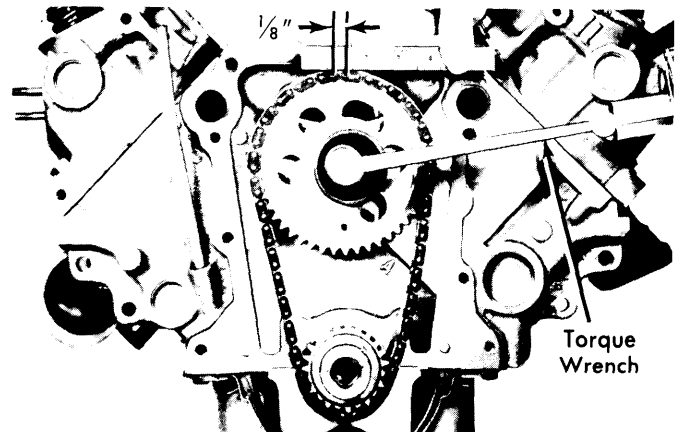

Fig. 13 Measuring Timing Chain Stretch

**Removal** — With front cover removed, remove camshaft sprocket attaching bolt, washer and fuel pump eccentric. Remove timing chain with crankshaft and camshaft sprockets.

**Installation** — When installing timing chain, use a suitable tool (C-3509) to prevent camshaft from contacting welch plug in rear of engine block. Remove distributor and oil pump distributor drive gear. Locate tool against rear side of cam gear and attach tool with distributor retainer plate bolt. Then proceed as follows:

1) Place camshaft and crankshaft sprockets on bench with timing marks on an imaginary centerline through bore of both sprockets. Place timing chain around both sprockets. Turn crankshaft and camshaft to line up with keyway location in sprockets.

## 318" &amp; 360" V8 ENGINES (Cont.)

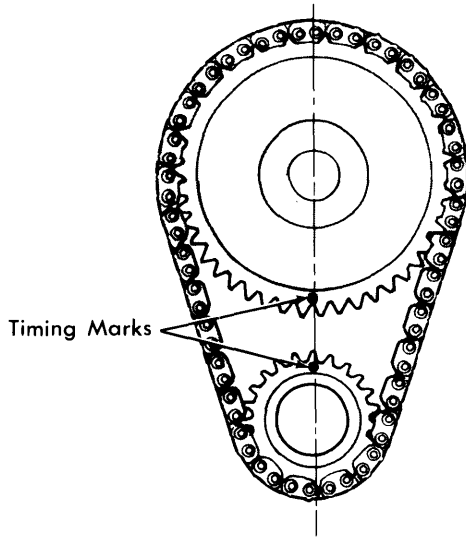

Fig. 14 Timing Chain Sprocket Alignment Marks

2) Slide both sprockets evenly over their respective shafts (with new chain installed on sprockets). Use a straightedge to measure alignment of timing marks. Install fuel pump eccentric, cup washer and camshaft bolt. Tighten bolt and check camshaft end thrust. Slide crankshaft oil slinger over shaft and up against sprocket (flange away from sprocket). Install front cover.

**CAMSHAFT**

**NOTE** — Whenever a new camshaft is installed; inspect and check, with a straightedge, all tappet faces for "dishing". Replace any tappet with a negative crown.

**Removal** — With engine removed from vehicle, remove intake manifold, front cover and timing chain. Remove rocker arm and shaft assemblies. Remove push rods and tappets.  
**NOTE** — Identify push rods and tappets for reinstallation in

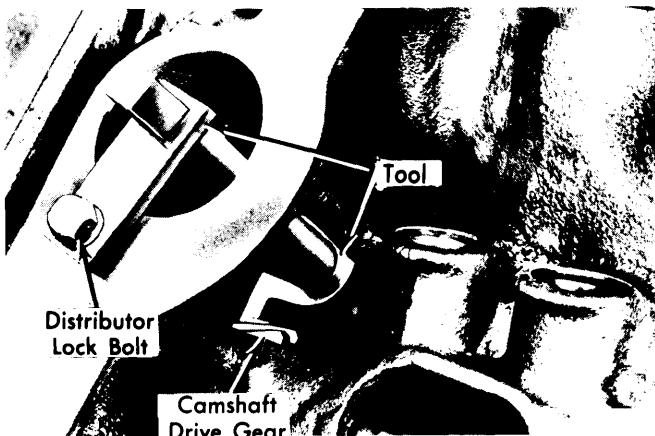

Fig. 15 Camshaft Holding Tool (C-3509) Installed

original location. Remove distributor and lift out distributor drive shaft. Remove camshaft thrust plate and note location of oil tab. Install a long bolt into front of camshaft to facilitate removal, and carefully remove camshaft.

**Installation** — Lubricate camshaft lobes and bearing journals. Insert camshaft to within 2" of its final position in block. Install suitable tool (C-3509) in distributor drive hole and hold in position using distributor retainer plate bolt. **NOTE** — Tool should remain in position until sprockets and timing chain are installed. Install camshaft to final position. Install thrust plate and chain oil tab. **CAUTION** — Top edge of tab should be flat against thrust plate to provide oil for chain lubrication. Install remaining components in reverse order of removal. See *Distributor Timing and Installation*.

**CAMSHAFT BEARINGS**

**Removal** — With engine completely disassembled, drive out rear cam bearing welch plug. Install proper size adapters and horseshoe washers (C-3132A) at rear of each bearing to be removed and drive out bearings.

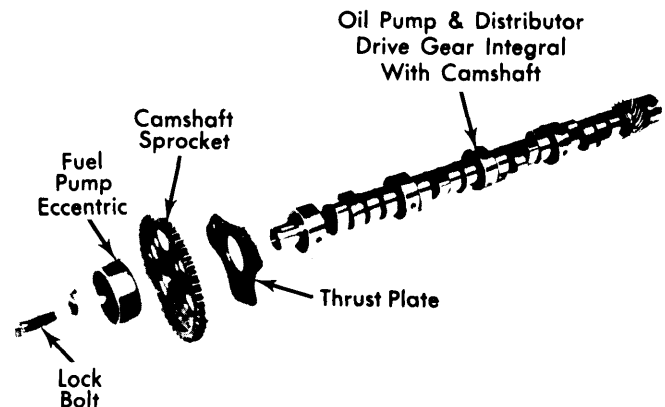

Fig. 16 Exploded View of Camshaft Assembly

**Installation** — Slide new rear bearing over proper adapter of suitable tool, install horseshoe lock and carefully drive bearing into place. Install remaining bearings in same manner while noting the following: Bearings must be aligned to bring oil holes in line with oil passages from main bearing. Number two bearing must index with oil passage to left cylinder head and number four bearing must index with oil passage to right cylinder head. Install a new welch plug at rear of camshaft. **CAUTION** — Plug must not leak.

**CAMSHAFT END THRUST**

End thrust is taken by thrust plate behind camshaft sprocket. End play should be .002-.010". If not within specifications, replace thrust plate.

## 318" & 360" V8 ENGINES (Cont.)

### DISTRIBUTOR TIMING & INSTALLATION

**Distributor Timing** — Before installing distributor-oil pump drive shaft, time engine as follows: Rotate crankshaft so number one cylinder is at top dead center on firing stroke. Straight line on vibration damper should be under "O" on timing indicator. Coat shaft and drive gear with engine oil. Install shaft so that when gear spirals into place, it will index with oil pump shaft, so slot in top of drive gear will point straight down lifter bosses, parallel with camshaft (see Fig. 18).

**Distributor Installation** — Hold distributor over mounting pad of cylinder block with vacuum chamber pointing toward right of engine. Turn rotor to point forward and approximately toward location of number one terminal in distributor cap. Place distributor gasket in position, lower distributor and engage shaft in slot of distributor drive shaft gear. Turn distributor clockwise until breaker points are just separating and install hold down clamp.

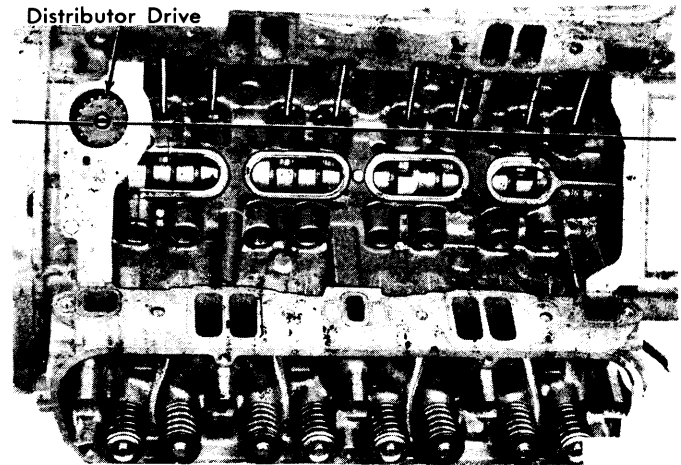

Fig. 18 Alignment of Distributor Gear with Engine for Distributor Timing

### ENGINE OILING

**Crankcase Capacity** — Capacity of 318" and 360" engines is 5 quarts. 360-3" engines require 6 quarts. On all engines, add 1 quart with oil filter change.

**Oil Filter** — Change at first oil change and every second oil change after that.

**Pressure Regulator Valve** — In oil pump. Not adjustable.

Application	Normal Oil Pressure (Hot)	PSI @ RPM
All Engines.....		30-80@2000

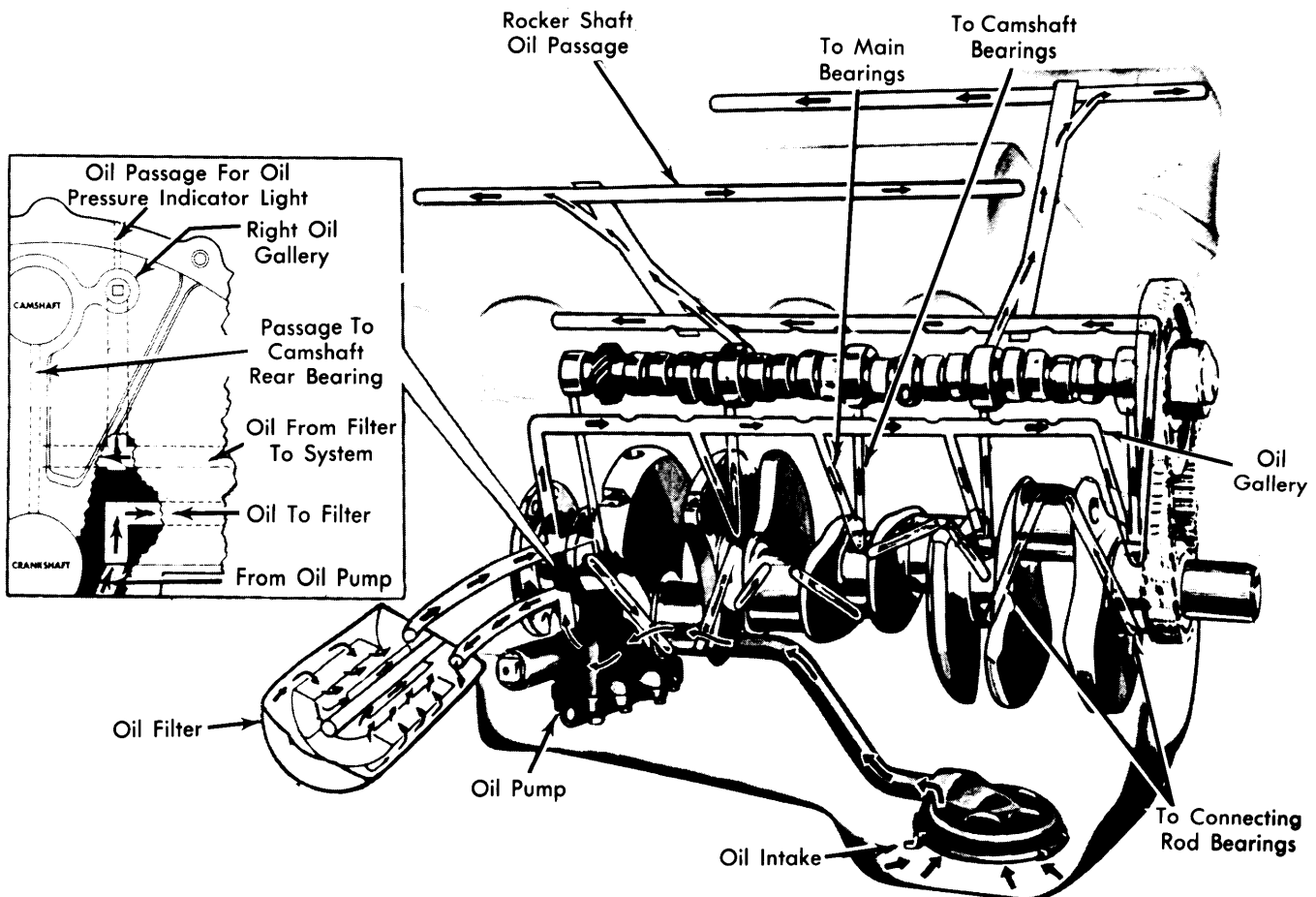

Fig. 17 Chrysler Corp. 318" & 360" Engine Oiling System

## 318" &amp; 360" V8 ENGINES (Cont.)

## ENGINE OILING (Cont.)

## ENGINE OILING SYSTEM

See illustration. System has a rotor type oil pump and full flow type oil filter. Oil is forced by the oil pump to a series of oil passages in engine to provide lubrication to engine components. Oil is supplied to hollow rocker arm shaft (left side) from No. 2 camshaft bearing and to hollow rocker arm shaft (right side) from No. 4 camshaft bearing through indexed holes in camshaft. Oil enters rocker arm shaft through second rocker arm bracket from front (left side) and second bracket from rear (right side) to lubricate rocker arm assembly. Valve assembly is lubricated by oil spray from drilled holes in rocker arms.

## OIL PUMP

Disassemble (see Fig. 19), clean and inspect all parts for proper clearances (see specifications). NOTE — Inner rotor and shaft assembly can only be replaced if outer rotor is replaced, as units are a matched assembly.

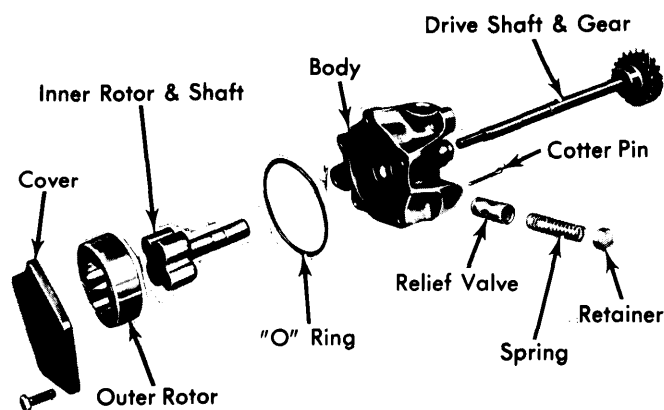

Fig. 19 Exploded View of Oil Pump Assembly

## Oil Pump Specifications

Cover Distortion	.0015" Max.
Clearance Over Rotors	.004" Max.
Inner & Outer Rotor Thickness	.825" Min.
Outer Rotor Diameter	2.469" Min.
Outer Rotor-to-Pump Body	.014" Max.

**Pressure Relief Valve Spring** — Spring has a free length of  $2\frac{1}{32}$ - $2\frac{3}{64}$ ". Spring should test 16.2-17.2 lbs. when compressed to  $1\frac{1}{32}$ ". Replace springs which do not meet specifications.

## TIGHTENING SPECIFICATIONS

Application	Ft. Lbs.
Camshaft Sprocket Bolt	
318" & 360"	50
360-3"	35
Camshaft Thrust Plate	
318" & 360"	17.5
360-3"	16.6
Front Cover Bolt	35
Connecting Rod Nut	45
Crankshaft Damper Bolt	135
Cylinder Head Bolt	
318" & 360"	95
360-3"	85
Exhaust Manifold Nuts & Bolts	
Bolts	20
Nuts	15
Flywheel-to-Crankshaft	55
Flywheel Housing-to-Cylinder Block	50
Intake Manifold Bolt	
318" & 360"	40
360-3"	35
Main Bearing Cap Bolt	85
Oil Pan Bolt	16.6
Oil Pump Attaching Bolt	
318" & 360"	30
360-3"	35
Rocker Arm Shaft Retaining Bolt	16.6