

# Chrysler Corp. 6 Engines

## 225" 6 CYLINDER ENGINE

GENERAL SPECIFICATIONS							
Year	Displ. Cu. Ins.	Carburetor	HP at RPM	Torque (Ft. Lbs. at RPM)	Compr. Ratio	Bore	Stroke
1976	225"	1-8bl.	.....	.....	8.4:1	3.40"	4.125"

### ENGINE IDENTIFICATION

Engine Identification Number is stamped on block below number 1 spark plug. First three numerals designate engine cubic inch displacement.

Application	Numerals
225" .....	225

### SPECIAL ENGINE MARKS

Special engine marks are stamped on the cylinder block after the serial number and are decoded as follows:

**Maltse Cross (⌘)** — .001" undersize crankshaft journals. "M" or "R", representing "main" or "rod" followed by the cylinder number of journals concerned, will be found stamped on a crankshaft counterweight.

**Maltse Cross (⌘) And "X"** — .010" undersize crankshaft journals. "M" or "R" will be found stamped on a crankshaft counterweight.

"A" — Indicates all cylinder bores .020" oversize.

"♦" — Indicates .008" oversize tappets.

"O/S" — Indicates .005" oversize valve stems and is stamped on the thermostat boss at front of cylinder head.

### ENGINE REMOVAL

See *Engine Removal at end of Engine Section.*

### MANIFOLD ASSEMBLY

**Removal** — Disconnect all hoses and lines from air cleaner and remove air cleaner. Remove carburetor air heater, disconnect all lines and linkage to carburetor and remove carburetor. Disconnect exhaust pipe at manifold. Remove nuts and washers securing manifold assembly to cylinder head and remove manifold. Remove three screws securing intake manifold to exhaust manifold and separate manifolds.

**Installation** — Install new gasket between intake and exhaust manifold and install three screws securing manifolds together. Do not tighten screws at this time. Position manifold assembly on cylinder head using a new gasket. Install washers with cup side against manifold and snug all nuts. Tighten three intake to exhaust screws starting with inner screw. Start at

center of manifold assembly and work outward, tightening manifold nuts. Reinstall carburetor, linkage, hoses and air cleaner.

### CYLINDER HEAD

**Removal** — Drain cooling system. Remove air cleaner, fuel line and vacuum control tube at carburetor and distributor. Disconnect accelerator linkage, spark plug wires, temperature sending unit wire and all hoses to cylinder head. Disconnect exhaust pipe at manifold, diverter valve vacuum line from intake manifold and remove air tube assembly from cylinder head. Remove intake and exhaust manifold with carburetor, as an assembly. Remove crankcase vent valve with tube, closed ventilation system, and evaporation control system (if equipped). Remove rocker arm cover, rocker arm and shaft assembly. Remove push rods and identify to insure installation in original location. Remove cylinder head bolts, cylinder head and gasket.

**Installation** — Clean all gasket surfaces of cylinder block and head. Coat new gasket with suitable sealer. Install gasket and cylinder head on cylinder block. Install cylinder head bolts and tighten to specifications in two steps. Use tightening sequence shown in illustration. **NOTE** — Do not retighten bolts after engine has been operated when steel head gaskets are used.

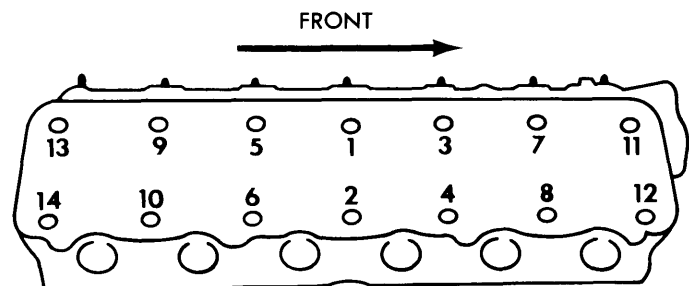

Fig. 1 Diagram Showing Correct Cylinder Head Tightening Sequence

VALVES							
Engine & Valve	Head Diam.	Face Angle	Seat Angle	Seat Width	Stem Diameter	Stem Clearance	Valve Lift
225"							
Int.	1.620"	45°	45°	$\frac{1}{16}$ - $\frac{3}{32}$ "	.372-.373"	.001-.003"	.406"
Exh.	1.360"	43°	45°	$\frac{3}{64}$ - $\frac{1}{16}$ "	.371-.372"	.002-.004"	.414"

## 225" 6 CYLINDER ENGINE (Cont.)

### VALVE ARRANGEMENT

E-I-E-I-E-I-E-I-E-I-E (front to rear).

### VALVE GUIDE SERVICING

**Wear Check** — Remove valve springs and install suitable sleeve over valve stem and install valve in cylinder head. Attach suitable dial indicator to cylinder head and position indicator at a right angle to valve stem being measured. Total sideplay should not exceed .017". If dial reading is excessive or stems are scuffed or scored, ream guides for installation of valves with oversized stems.

**Servicing** — Ream guides to next oversize valve stem if necessary. Oversize valve stems are available in .005", .015" and .030" oversize. **NOTE** — Do not attempt to ream guides from standard diameter to .030" oversize in one step. Use step procedure to obtain the .030".

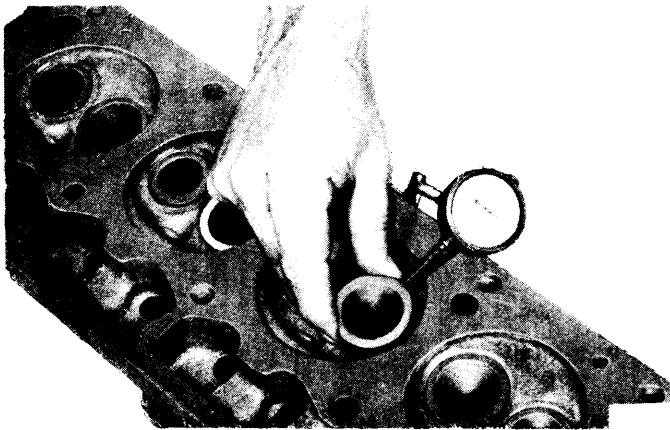

Fig. 2 Using Dial Indicator to Measure Valve Stem-to-Guide Clearance

### VALVE STEM OIL SEALS

Cup type seal is used on all valves. Long seal is used on intake valve and short seal is used on exhaust valve. If seals are removed for any reason, new seals must be used upon assembly.

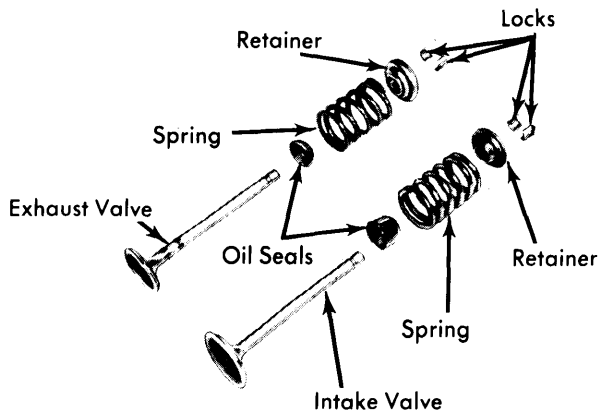

Fig. 3 Exploded View of Intake & Exhaust Valve Assemblies

VALVE SPRINGS			
Engine	Free Length	PRESSURE (LBS.)	
		Valve Closed	Valve Open
225"	1.92"	49-57@1 $\frac{1}{16}$ "	137-150@1 $\frac{5}{16}$ "

### VALVE SPRINGS

**Removal** — With cylinder head removed, compress valve springs using a suitable tool (C3422A). Remove valve retaining locks, valve spring retainers, valve springs and valve stem cup seals. **NOTE** — Remove any burrs from valve stem lock grooves to prevent damage to valve guide if valves are removed.

**Inspection** — Whenever valve springs have been removed, they must be tested. Using a suitable tester, the valve springs should test 137-150 lbs. when compressed to a height of 1 $\frac{5}{16}$ ". Replace springs which do not meet specifications. Inspect each valve spring for squareness using a steel square and surface plate. If spring is more than  $\frac{1}{16}$ " out-of-square, a new spring must be installed.

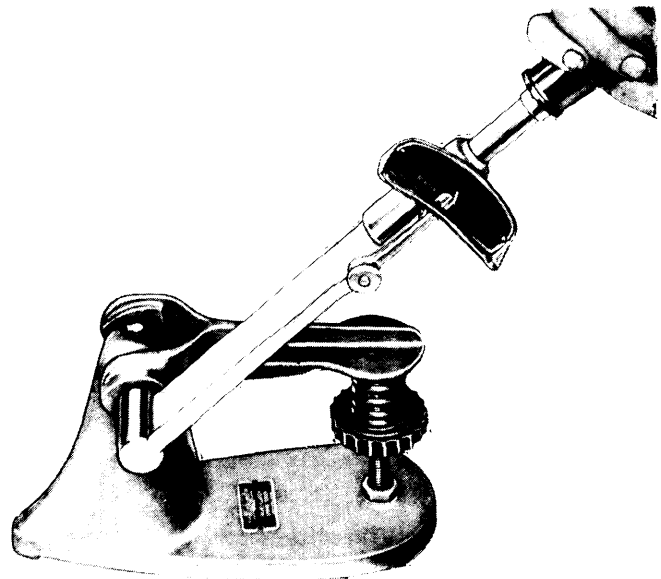

Fig. 4 Testing Valve Spring Tension

**Installation** — Coat valve stems with engine oil and insert valves in cylinder head. Install new cup seals on all valve stems and over valve guides. Install valve springs and retainers. Install springs so closed coils are against cylinder head. Compress valve springs using suitable tool (C-3422A), install valve locks and release tool.

### VALVE SPRING INSTALLED HEIGHT

If valves and/or seats are reground, measure installed height of springs. Measurement is taken from bottom of spring seat in cylinder head to bottom surface of spring retainer. **NOTE** — If spacers are installed measure from top of spacer. Installed height should be 1 $\frac{3}{8}$ " to 1 $\frac{11}{16}$ ". If exhaust valves are equipped with positive type rotators, height should be 1 $\frac{33}{64}$ " to

## 225" 6 CYLINDER ENGINE (Cont.)

$1\frac{3}{64}$ ". If not within specifications, install a  $\frac{1}{16}$ " spacer at head counterbore to correct spring height. **CAUTION** — Do not shim to a height less than specifications.

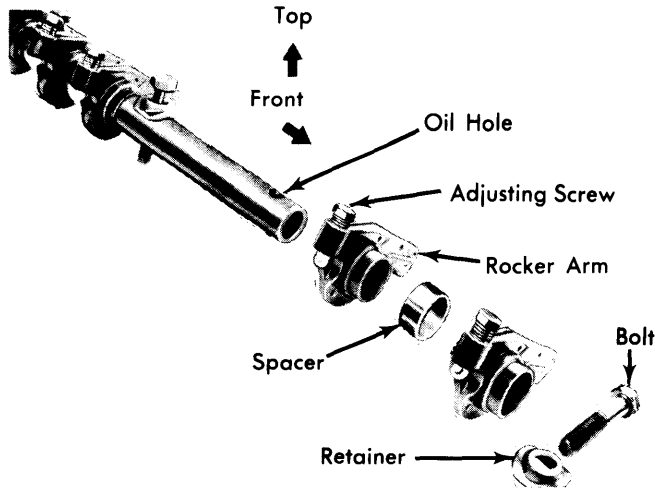

Fig. 5 Exploded View of Portion of Rocker Arm Shaft Assembly

### ROCKER ARM ASSEMBLY

Stamped steel rocker arms are arranged on a rocker arm shaft. Hardened steel spacers are used between pairs of rocker arms. Shaft is supported and attached to seven mounts on cylinder head. See illustration for assembly of parts, noting the following: The flat and oil hole on rocker arm shaft must be installed upward and toward front of engine for proper lubrication. Install long retainer at center position and long shaft bolt at rear of engine. Shaft retainers must seat on rocker shaft and not on extended bushing of rocker arm.

### MECHANICAL VALVE LIFTER ADJUSTMENT

Temporarily set intake to .015" and exhaust to .025" with engine cold. **NOTE** — On Plymouth Voyager and Dodge Vans set intake to .012" and exhaust to .028". Operate engine until normal operating temperature is reached (approximately 185°F water temperature). Allow engine to idle at 550 RPM at operating temperature for five minutes. Adjust intake to .012" and exhaust to .024" with engine at operating temperature. **NOTE** — On Plymouth Voyager and Dodge Vans set intake to .010" and exhaust to .020".

PISTONS, PINS, RINGS						
Engine	PISTONS	PINS		RINGS		
	Clearance	Piston Fit	Rod Fit	Rings	End Gap	Side Clearance
225"	.0005-.0015"	.00045-.00075"	.0007-.0017"	1 & 2 3	.010-.020" .015-.055"	.0015-.003" .002-.005"

### OIL PAN

See Oil Pan Removal at end of Engine Section.

### PISTON & ROD ASSEMBLY

**Removal** — With cylinder head and oil pan removed, use a suitable ridge cutter (C-3012) to remove any ridge or deposits on upper end of cylinder bore. **NOTE** — Piston must be at bottom of stroke and covered with cloth to collect cutting. Inspect connecting rods and caps for cylinder identification and mark as necessary. Rotate crankshaft so each connecting rod is centered in cylinder bore for removal. Remove rod cap and push piston and rod assembly out top of cylinder block, taking care not to nick crankshaft journal or cylinder wall. Install rod caps on mating rods.

**Installation** — 1) Compression ring gaps must be located on piston so they will be on left side of engine and staggered about 60° apart. **NOTE** — Neither gap should line up with oil ring rail gaps and identification "TOP" on each compression ring should face top of piston. Rotate oil ring expander so gaps are at right side of engine and rotate steel rails so gaps are opposite (positioned above piston pin holes).

2) Lightly coat cylinder bores, pistons and rings with engine oil, slide suitable ring compressor over piston and tighten. **NOTE** — Do not allow position of rings to change during this operation. Install each piston and rod assembly, with notch on piston head facing front of engine and oil hole in connecting rod toward right side of engine, in its respective bore and

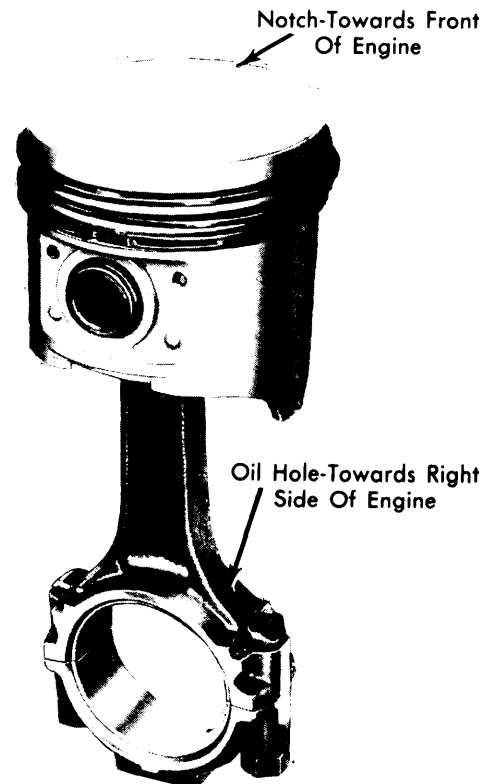

Fig. 6 View Showing Correct Assembly of Rod-to-Piston

## 225" 6 CYLINDER ENGINE (Cont.)

guide connecting rod onto crankshaft journal. Tap piston head lightly with hammer handle to seat connecting rod and bearing against crankshaft. Install rod cap with bearing, nuts and tighten.

### FITTING PISTONS

1) With pistons and cylinder bores dry and clean, measure for piston-to-cylinder wall clearance. Measurements should be taken at room temperature (70°F). Measure piston diameter at top of skirt, 90° to piston pin axis. Measure cylinder bore halfway down cylinder and 90° to crankshaft center line.

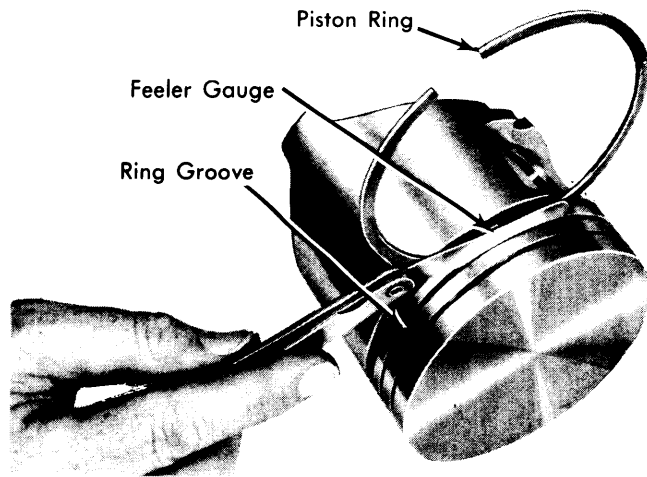

Fig. 7 Using Feeler Gauge to Measure Ring Side Clearance

2) Check cylinder bore for taper or out-of-round conditions using a micrometer or cylinder gauge. Cylinder bore must not show more than .005" out-of-round or taper more than .010". If taper and out-of-round are not within specifications, or cylinder walls are scuffed or scored, cylinders should be honed before installing new rings. If cylinders are honed, they must be thoroughly washed with soapy water before installing pistons. For cylinders which have been honed or rebored, pistons assemblies are available in .005", .020" and .040" oversize.

3) Check ring end gap in cylinder bore with a feeler gauge. Ring must be square in bore and about 2" from bottom of cylinder bore to which it is being fitted. Check ring side clearance in ring groove of piston with a feeler gauge. Steel rail service oil ring should be free in groove and all ring grooves in piston must be clean.

### PISTON PINS

**Removal** — Arrange suitable tool (C-3724) parts for removal of piston pin as shown in illustration and note the following: Spring must be removed from tool anvil. Install nut loosely on main screw. When pin falls free from connecting rod, stop press to prevent damage to bottom of anvil.

**Installation** — Measure piston pin fit in the piston. If pin is not a sliding fit in piston at 70°F, piston pin and piston must be

replaced as an assembly. Lubricate piston pin holes in piston and connecting rod. Arrange suitable tool(C-3724) parts for installation of piston pin as shown in illustration and note the following: Install spring inside pilot and install spring and pilot in the anvil. Position piston with notch up and oil hole in connecting rod so oil hole will face right side of engine upon installation. Press pin into position until pin bottoms on pilot of tool.

**Checking Pin Fit** — Arrange suitable tool (C-3724) parts as for removal of piston pin. Place assembly in a vise, attach torque wrench to nut and test torque up to 15 ft. lbs. If connecting rod moves downward on piston pin, replacement is necessary.

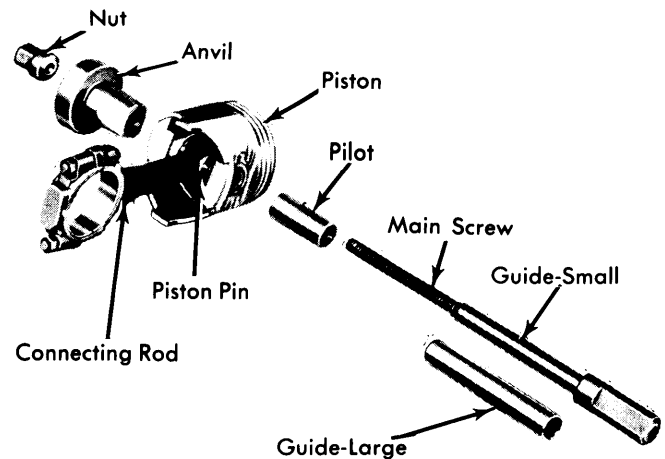

Fig. 8 Correct Procedure to Remove Piston Pin

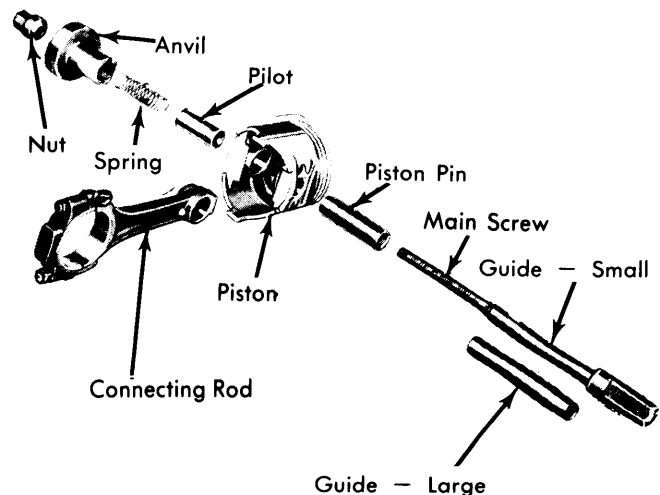

Fig. 9 Correct Procedure to Install Piston Pin

## 225" 6 CYLINDER ENGINE (Cont.)

CRANKSHAFT MAIN & CONNECTING ROD BEARINGS							
Engine	MAIN BEARINGS				CONNECTING ROD BEARINGS		
	Journal Diam.	Clearance	Thrust Bearing	Crankshaft End Play	Journal Diam.	Clearance	Side Play
225"	2.750"	.0005-.002"	No. 3	.002-.009"	2.187"	.0005-.0025"	.006-.012"

## MAIN &amp; CONNECTING ROD BEARINGS

**NOTE** — Plastigage method for checking bearing clearances may be used in place of Shim Stock Method. The following procedures are with oil pan and oil pump removed.

**Connecting Rod Bearings** — 1) After ensuring rod caps are marked for cylinder identification, remove rod caps. Smooth edges of a  $\frac{1}{2}$ " by  $\frac{3}{4}$ " piece of brass shim stock .001" thick. Oil and place between the bearing and connecting rod journal. Install bearing cap and tighten. Rotate crankshaft  $\frac{1}{4}$  turn in each direction (Shim Stock Method for checking clearances). If a slight drag is felt, clearance is within limits. If no drag is felt, clearance is excessive. If crankshaft cannot be rotated, clearance is not enough.

2) New bearings are available in standard, .001", .002", .003", .010" and .012" undersize. Taper or out-of-round on any crankshaft journal should not exceed .001". Always install new bearings in pairs. **NOTE** — Never use a new bearing with an old bearing on the same journal. Install bearings so small formed tang fits into machined groove in connecting rod. Install rod caps and tighten nuts.

**Main Bearings** — 1) Use Shim Stock Method and check main bearing clearances, one at a time while all other main bearing caps are tight. New bearings are available in standard, .001", .002", .003", .010" and .012" undersize. A new .001" bearing may be used in combination with a new standard bearing or a .002" with a .001". **NOTE** — Always use smaller diameter bearing as the upper bearing and never use a new bearing with an old bearing on the same journal.

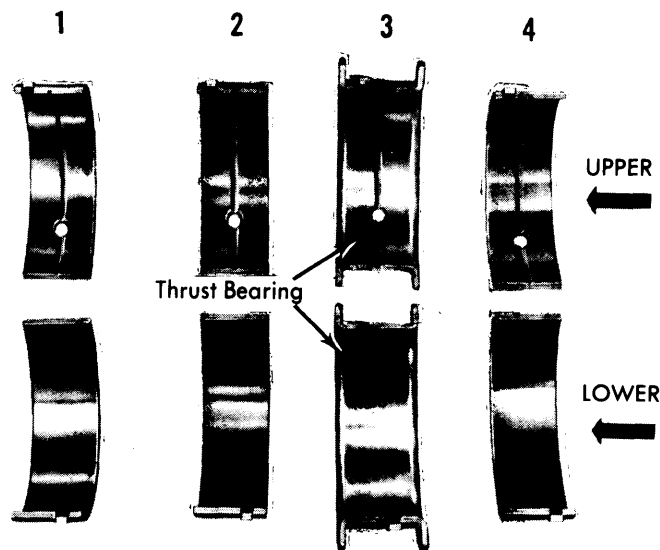

Fig. 10 Main Bearing Identification Showing Location of Thrust Bearing

2) Upper main bearings are grooved and lower main bearings are plain and are not interchangeable. Lower main bearings one, two and four are interchangeable. Upper main bearings two and four are interchangeable. Upper main bearing one is chamfered on tab side for timing chain oiling and can be identified by a red marking on edge of bearing. This bearing is not interchangeable.

3) If bearing clearances are not within limits, remove bearing cap, insert suitable tool (C-3509) in oil hole journal and rotate crankshaft clockwise to remove upper bearing. To install new bearing, slightly chamfer sharp edges from plain side and start bearing in place. Insert tool and slowly rotate crankshaft counterclockwise, sliding bearing in place. Install main bearing cap with new bearing installed and tighten.

4) Check crankshaft end play and if not within specifications, change number three main bearing. This bearing carries thrust load.

## REAR MAIN BEARING OIL SEAL

New split type rubber seals may be replaced without removing the crankshaft. New type seals must be installed as a pair and cannot be used or combined with old type rope seals.

**Removal** — Remove upper rope seal by turning suitable tool (C-4148) into end of seal and pulling seal out with tool, being careful not to mar crankshaft. Remove lower seal by carefully prying from the side with a small screwdriver.

**Installation** — Oil upper seal lightly with engine oil. Hold seal (with paint stripe to rear) tightly against crankshaft with a thumb and rotate crankshaft while sliding seal into groove. **CAUTION** — Sharp edge of groove in block may shave or nick the back of seal. Care must be exercised not to damage the sealing lip. Install lower half of seal into lower seal retainer with paint stripe to the rear. Install main bearing cap and tighten. Install lower seal retainer and tighten. **NOTE** — Do not use sealer or cement on seal ends or lip.

## ENGINE FRONT COVER

**Removal** — Drain cooling system and remove radiator from vehicle. Remove drive belts, fan and pulley from water pump hub. Using a suitable puller (C-3732A), remove vibration damper. Loosen oil pan bolts to provide clearance between pan and lower flange of cover. Remove front cover attaching bolts and cover.

**Installation** — Check that mating surfaces of front cover and cylinder block are clean and free of burrs. Install cover with new gasket and tighten bolts. Tighten oil pan bolts with gaskets in place. Lubricate front cover seal lip with Lubriplate, position vibration damper hub slot on key in crankshaft and slide hub onto crankshaft. Position suitable installing tool (part of C-3732A) in position and press vibration damper assembly on crankshaft. Install drive belt pulley, fan and drive belts. Install radiator. Adjust drive belt tension and fill cooling system.

## 225" 6 CYLINDER ENGINE (Cont.)

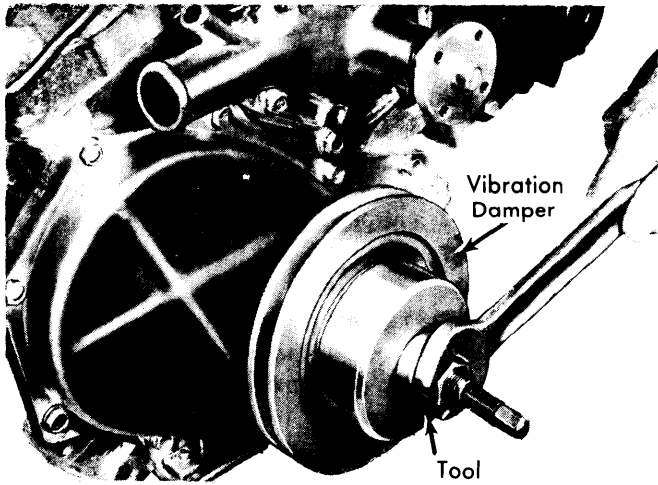

Fig. 11 Correct Procedure to Install Vibration Damper

### FRONT COVER OIL SEAL

**Removal** — With front cover removed, use a drift and hammer to lightly tap at several positions around seal case to deform seal inward. **CAUTION** — Support front cover at seal area to prevent deforming front cover. Using vise grips, twist and pull seal at several positions to remove seal from cover.

**Installation** — Use a suitable tool (C-3506) to press seal into front cover. Seal is properly installed when seal case is tight against face of cover. A .0015" feeler gauge should not be able to enter between neoprene face and cover (see illustration).

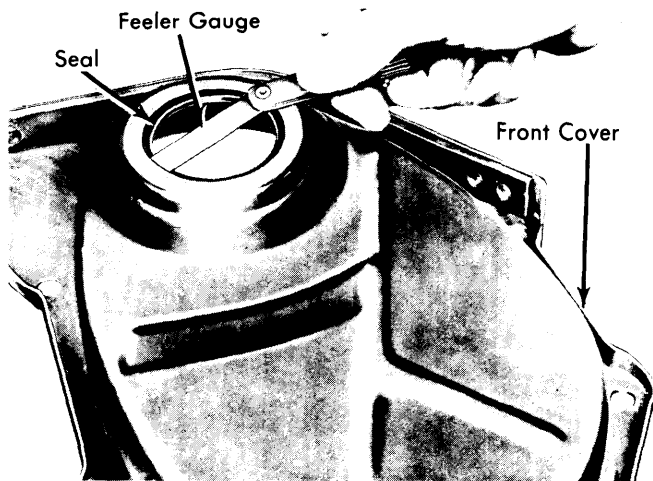

Fig. 12 Using Feeler Gauge to Check Front Cover Seal Installation

CAMSHAFT			
Engine	Journal Diam.	Clearance	Lobe Lift
225"	No. 1 1.998"	.001-.003"	.....
	No. 2 1.982"		
	No. 3 1.967"		
	No. 4 1.951"		

### TIMING CHAIN

**Checking For Stretch** — Position scale next to timing chain (see illustration) to measure any movement of the chain. Place torque wrench with socket over camshaft sprocket lock bolt and apply torque in direction of crankshaft rotation to remove slack. Torque should be 30 ft. lbs. with cylinder heads installed or 15 ft. lbs. with cylinder heads removed. **NOTE** — Do not permit the crankshaft to move. Apply same torque in reverse direction and measure amount of chain movement. If movement exceeds  $\frac{1}{8}$ ", install a new timing chain.

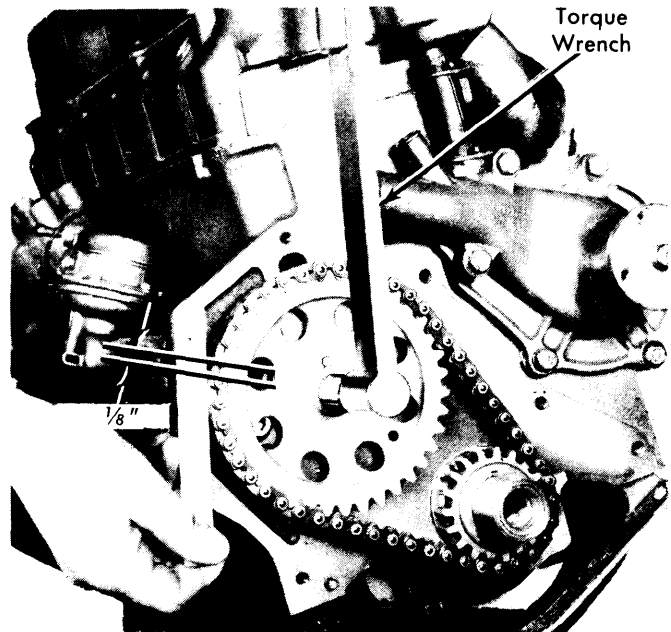

Fig. 13 Measuring Timing Chain Stretch

**Removal & Installation** — Remove camshaft sprocket attaching bolt and remove timing chain with camshaft sprocket. Turn crankshaft to line up centerline of camshaft and crankshaft with the timing mark on crankshaft sprocket (see illustration). Install camshaft sprocket and timing chain, lining up timing marks on the sprockets with centerline of crankshaft and camshaft. Tighten camshaft sprocket bolt.

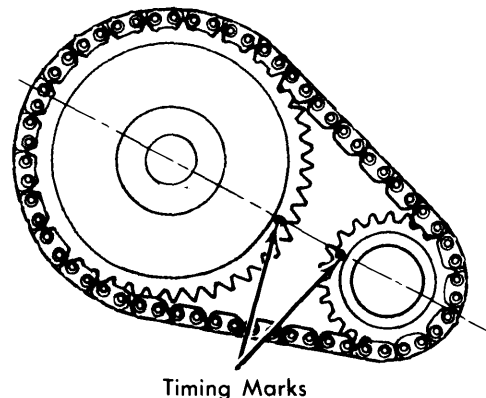

Fig. 14 Timing Chain Sprocket Alignment

## 225" 6 CYLINDER ENGINE (Cont.)

## CAMSHAFT

**Removal** — With engine removed from vehicle, remove cylinder head. Remove tappets using a suitable tool. Remove fuel pump, distributor and oil pump. Remove front cover and timing chain. Install a long bolt into front of camshaft and carefully remove camshaft. **CAUTION** — Take care not to damage bearings with cam lobes.

**Installation** — 1) Lubricate camshaft lobes and bearing journals and insert camshaft into cylinder block. Check all tappets with a straight edge for crown. If any negative crown (dishing) is observed, tappet must be replaced.

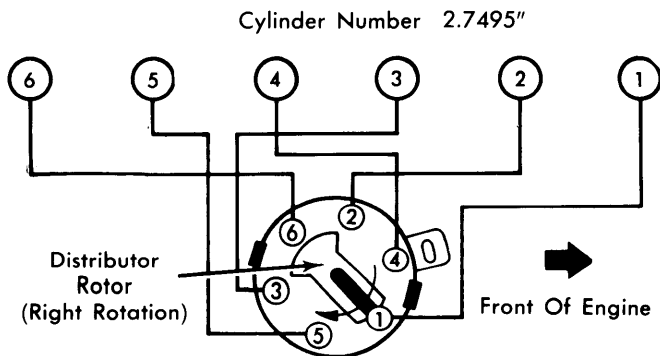

Fig. 15 Schematic Showing Distributor Wire Routing & Timing

**NOTE** — Tappet must have a definite crown. Install timing chain and sprockets, front cover, fuel pump and oil pump. Install tappets and cylinder head.

2) Install distributor, timing the engine as follows: Rotate crankshaft until mark on inner edge of crankshaft pulley is in line with the TDC mark on front cover. No. 1 piston should be at top dead center of compression stroke (both valves closed). With distributor "O" rings in position, hold distributor over mounting pad and turn rotor to point forward. Install distributor so that when fully seated on engine, the gear has spiraled to bring rotor to 5 o'clock position. Turn distributor so rotor is positioned directly under No.1 tower of distributor cap. Install and tighten distributor hold-down bolt.

## CAMSHAFT BEARINGS

**Removal** — With camshaft removed, drive out rear cam bearing welch plug. Install proper size adapters and horseshoe washers of suitable tool (C-3132A) at back of each bearing and drive out bearings.

**Installation** — Use suitable camshaft bearing tool (C-3132A or equivalent), slide bearing over proper tool adapter and install bearing in place. **NOTE** — Camshaft bearing oil hole must be in exact alignment with drilled oil passage from main oil bearing. Insert remaining bearings in similar manner. No. 1 bearing must be installed  $\frac{3}{32}$ " inward from front face of block.

Apply suitable sealing compound to new welch plug at rear of camshaft. Ensure that plug does not leak.

## ENGINE OILING

**Crankcase Capacity** — On all models, capacity is 5 quarts. Add one quart when changing filter.

**Oil Filter** — Replace every second oil change, following installation directions printed on case of new filter.

**Normal Oil Pressure** — 30-70 psi at 2000 RPM.

**Pressure Regulator Valve** — In oil pump body. Not adjustable.

## ENGINE OILING SYSTEM

See illustration. Rotor type oil pump mounted externally on right side of crankcase. Oil pump assembly consists of oil pump, oil filter and oil pressure regulator. Pump draws oil from oil pan through fixed strainer and intake pipe screwed into crankcase wall at pump mounting pad. Pump delivers oil directly into main oil gallery extending along right side of crankcase.

**Rocker Arms & Valves** — Transverse channel in rear camshaft journal feeds oil from rear camshaft bearing up through channel in block and cylinder head to rear rocker arm shaft bracket (oil flows around rear bracket bolt into rocker shaft). Trough on upper surface of rocker arm lubricates push rod seats and valve stems.

**Crankshaft Bearings** — All main bearings are lubricated as shown in illustration. Connecting rod bearings are lubricated by holes drilled in the crankshaft between main and connecting rod journals.

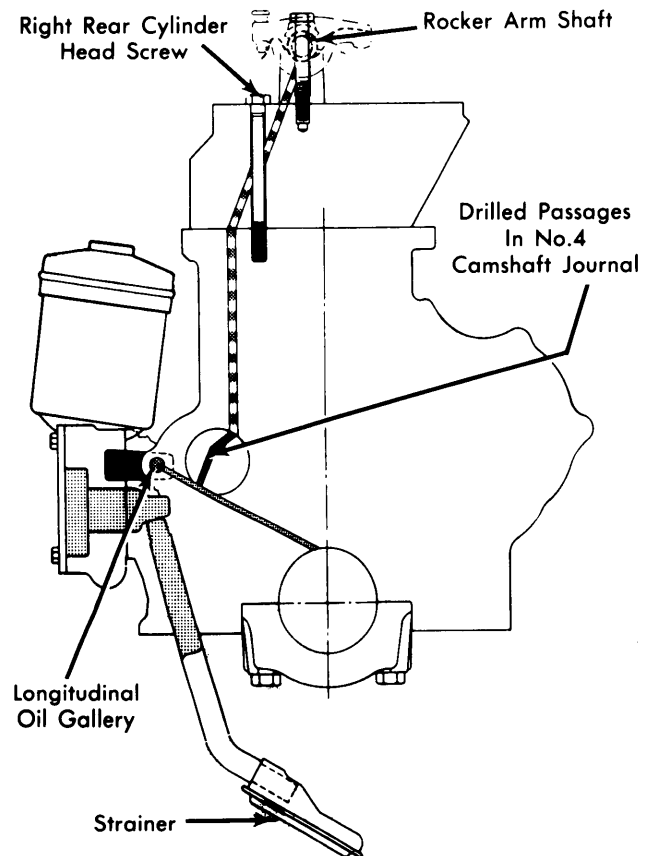

Fig. 16 Schematic of Engine Oiling System

## 225" 6 CYLINDER ENGINE (Cont.)

### ENGINE OILING (Cont.)

#### OIL PUMP

**Disassembly** — Remove pump cover and seal ring. Press off drive gear while supporting gear to eliminate load on aluminum body of pump. Remove outer rotor and inner rotor with shaft. Remove oil pressure relief valve plug, spring and valve.

**Inspection** — Clean all parts thoroughly. Mating face of oil pump cover should be smooth and must be replaced if scratched or grooved. Measure all clearances indicated in Oil Pump Specifications table and replace parts as follows:

- 1) Replace front cover if pump cover wear is excessive. Replace outer rotor if thickness and diameter are not within specifications. Replace inner rotor if thickness is not within specifications. Replace oil pump body if outer rotor-to-pump body is not within specifications.
- 2) Replace pump body if clearance over rotors is not within specifications. Replace both inner and outer rotors if tip clearance between rotors is not within specifications.

- 3) Relief valve spring should have free length of 2 1/4". Spring should test to 22.3-23.3 lbs. when compressed to 1 1/32". Replace spring which does not meet specifications.

#### Oil Pump Specifications

Pump Cover Wear.....	.0015" Max.
Inner & Outer Rotor Thickness .....	.649" Min.
Outer Rotor Diameter.....	2.469" Min.
Clearance Over Rotors .....	.004" Max.
Outer Rotor-to-Pump Body .....	.0014" Max.
Tip Clearance Between Rotors .....	.010" Max.

**Assembly** — Assemble pump in reverse order of disassembly using new parts as required. Prime oil pump before installation by filling rotor cavity with engine oil.

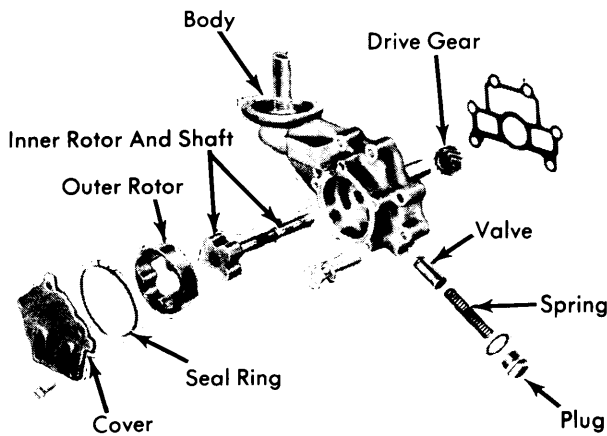

Fig. 17 Exploded View of Oil Pump Assembly

#### TIGHTENING SPECIFICATIONS

Application	Ft. Lbs.
Camshaft Lock Bolt .....	50
Connecting Rod Cap Bolt.....	45
Cylinder Head Bolts .....	70
Exhaust Manifold Nuts.....	10
Front Cover Bolts .....	200 INCH Lbs.
Fuel Pump Bolts.....	30
Intake-to-Manifold Bolts .....	20
Main Bearing Cap Bolts .....	85
Manifold-to-Cylinder Head Bolts.....	10
Oil Pump Attaching Bolts .....	200 INCH Lbs.
Oil Pump Cover Bolts .....	8
Rear Main Bearing Seal Retainer .....	30
Rocker Arm Cover Bolts.....	40 INCH Lbs.
Rocker Arm Shaft Bolts .....	25
Water Pump Bolts .....	30