

Propeller Shafts

UNIVERSAL JOINTS

► CHANGES, CAUTIONS & CORRECTIONS

► **UNIVERSAL JOINT DISASSEMBLY CAUTION** — Universal joints should not be disassembled or lubricated unless external leaking or damage has occurred. Before disassembly, scribe alignment marks on yoke and shaft so that shaft parts can be reassembled in their original position. If joints are rusted or corroded, apply penetrating oil before pressing out bearing cups or trunnion pin.

► **SLIP YOKE MAINTENANCE NOTE** — If slip yoke has a tendency to stick in extension housing seal, service as follows: Remove propeller shaft from vehicle and clean yoke with suitable solvent. Lubricate inside diameter of seal with synthetic oil seal lubricant and outside diameter of seal with transmission fluid. This procedure should also be followed whenever shaft is removed from vehicle.

CROSS AND ROLLER TYPE

NOTE — Two different retaining methods are used for bearing cups, snap ring or nylon retainers. Joints with snap rings may be taken apart and reassembled using same cross and bearings. Joints with nylon retainers are disassembled by breaking nylon retainers, therefore they must be replaced when they are serviced.

DISASSEMBLY

Disconnect yoke attaching bolts or flange attaching bolts and remove propeller shaft from vehicle. **CAUTION** — Do not use pry bar or heavy tool to hold propeller shaft when loosening flange bolts or U-bolts to prevent damage to universal joint bearing seals. Remove retaining strap (if used), remove

bushing retainers from yoke and press out rollers and bushings. Remove last roller and bushing assembly by pressing on end of cross. Remove cross assembly from yoke. Do not remove seal retainers from cross. Cross and retainers are serviced as an assembly.

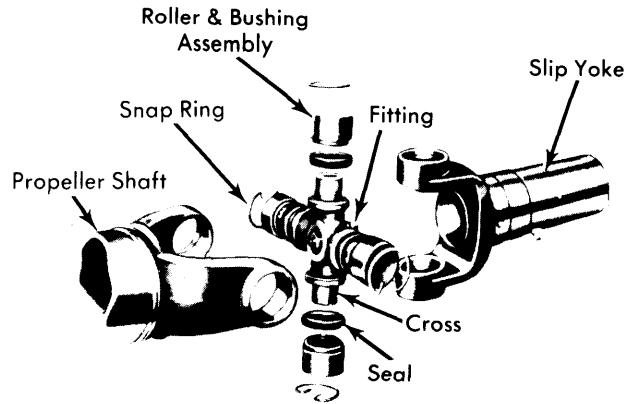

CROSS & ROLLER JOINT

4GM01

REASSEMBLY

Coat roller and bearing assemblies with suitable lubricant and fill reservoirs in ends of cross. Place cross assembly in propeller shaft yoke and place roller and bushing assemblies into position. Press both bushing assemblies into yoke until retainers can be installed, being careful to keep cross aligned in center of bushings. Install retainers, then repeat procedure for remaining bushings. Install retaining strap (if used). Install propeller shaft in vehicle, making sure marks made prior to disassembly are aligned.

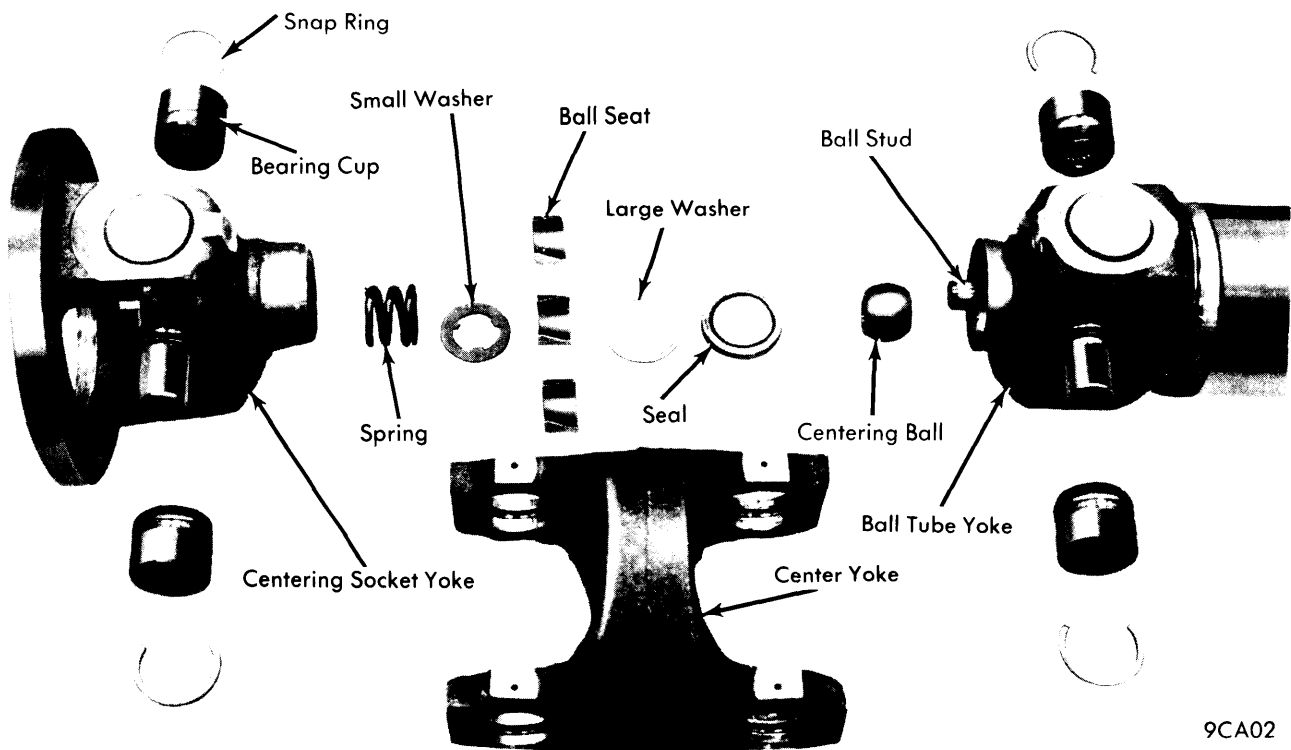

CONSTANT VELOCITY JOINT

9CA02

UNIVERSAL JOINTS (Cont.)

CONSTANT VELOCITY TYPE

CAUTION — To prevent damage to constant velocity joint center ball when removing propeller shaft assembly or when handling shaft after removal, care must be taken to support shafts on both sides of constant velocity joint if shaft is moved horizontally. Do not allow one end of shaft to hang free or allow universal joint to bend at a sharp angle. Shaft assembly may be carried in a vertical position without damage to constant velocity joint.

DISASSEMBLY

Disconnect yoke attaching bolts and flange attaching bolts and remove propeller shaft from vehicle. Mark joint so that center and end yokes and crosses will be reassembled in same

relative position. Pry out all snap ring bearing retainers and press out bearing enough to allow bearing end to be clamped in a vise. With edge of bearing held tightly in vise, tap on yoke until yoke comes off bearing. Repeat procedure for remaining bearings. Remove remaining parts from center yoke assembly.

REASSEMBLY

Pack all bearings with suitable grease and assemble center yoke components in reverse order of disassembly. Using arbor press or vise, press two opposing bearings into position at same time until all bearings are installed. **NOTE** — Make sure that crosses and yokes are properly aligned. Check for free movement of joint. If bind exists, seat bearings with a sharp rap on YOKES with a brass hammer. **CAUTION** — Never tap on bearings. Install propeller shaft in vehicle, making sure marks made prior to disassembly are aligned.