

Ford Motor Co. V8 Engines

360" & 390" V8 ENGINES

GENERAL SPECIFICATIONS							
Year	Displ. Cu. Ins.	Carburetor	HP at RPM	Torque (Ft. Lbs. at RPM)	Compr. Ratio	Bore	Stroke
1975	360"	2-Bbl.	4.05"	3.50"
	390"	2-Bbl.	4.05"	3.78"

ENGINE IDENTIFICATION

Rating plate carries information concerning vehicle model, series, point of manufacture, and unit number. Plate is located on cowl surface under hood. Number code is as follows:

F25YD50000

First Digit – Truck Series Letter.

Second & Third Digits – Truck Series Number.

Fourth Digit – Engine Code.

Fifth Digit – Assembly Plant.

Remaining Digits – Consecutive Unit Number.

ENGINE REMOVAL

See *Engine Removal* at end of *ENGINE* Section.

INTAKE MANIFOLD

Removal – 1) Drain cooling system. Remove air cleaner and crankcase vent hoses. Disconnect and remove or relocate all mechanical linkage and electrical connections.

2) Remove distributor cap and spark plug wires. Disconnect and remove distributor vacuum line at distributor. Remove distributor hold-down clamp and take out distributor.

3) Disconnect all radiator and heater hoses. Remove rocker arm covers. Following procedure given in *Rocker Arm Assembly Removal*, remove rocker arm shaft assembly.

4) Remove valve push rods in sequence in order to return to original positions. Remove intake manifold attaching bolts. Install suitable eye bolts into left front and right rear rocker arm cover screw holes and attach engine lifting sling.

Engine	Engine Code Identification	Code Letter
360"		Y
390"		H

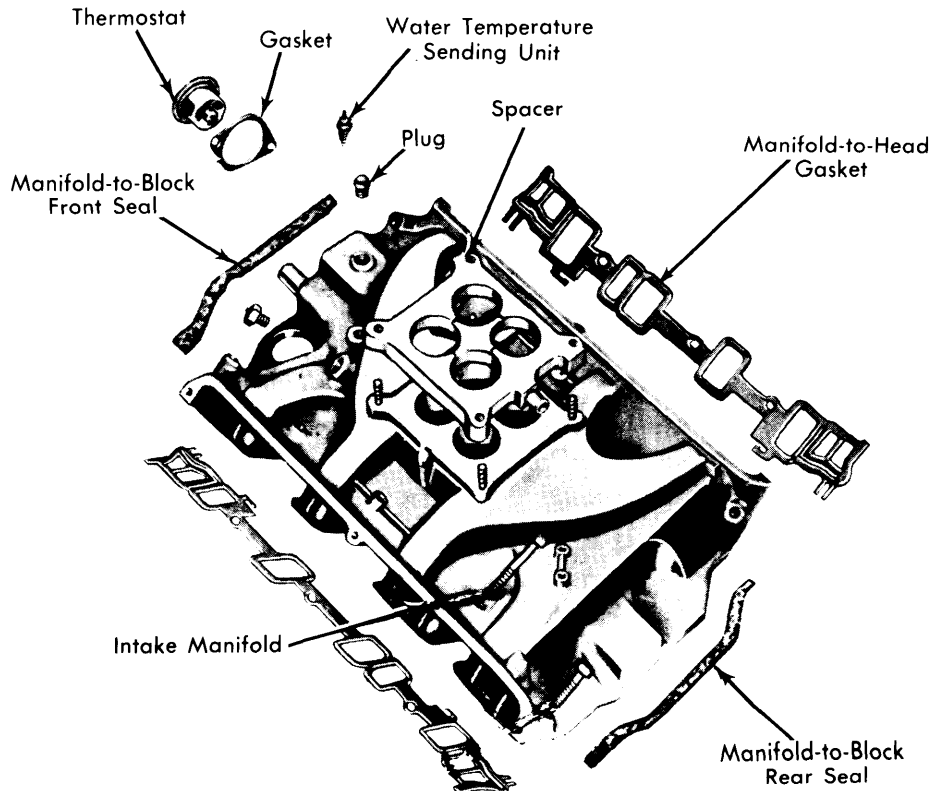

5F08001

INTAKE MANIFOLD & RELATED PARTS

360" & 390" V8 ENGINES (Cont.)

5) Using engine lifting sling, carefully remove intake manifold assembly. Remove old intake gaskets and seals. Disassemble all necessary parts.

Installation - 1) Clean mating surfaces of intake manifold, cylinder head, and cylinder block assembly. Replace all parts removed from manifold, making sure that EGR spacer gasket is installed correctly.

2) Carefully position new seals and gaskets on cylinder heads and block assembly. Position manifold gasket slots over end tabs on seals. Coat corners of gaskets and seals with suitable non-hardening gasket sealer. Be sure holes in gaskets are aligned with holes in cylinder heads.

3) Reinstall eye bolts into intake manifold, attach engine lifting sling and carefully replace intake manifold on engine. Position manifold by inserting distributor into manifold. Check to see that no gaskets have slipped out of position around edges of manifold.

4) Be sure holes in gaskets and intake manifold are in alignment. Coat underside of head of each manifold retaining bolt with non-hardening sealer prior to installation. Install retaining bolts and torque bolts in sequence shown in illustration.

5) Remove distributor, lifting sling, and eye bolts. Reconnect all radiator and heater hoses. Apply Lubriplate or equivalent to both ends of push rods and reinstall in original locations, positioning lower ends of push rods in lifter cups. Refer to Rocker Arm Shaft Installation for procedure to reinstall valve rocker arm shaft assembly.

6) Place distributor into engine and set to correct position for operation. Replace rocker arm cover gaskets and install valve rocker arm covers on engine. Reinstall all mechanical linkage and electrical connections to proper locations on engine assembly. Reinstall air cleaner and vent hoses and start engine to check for any leaks or malfunctions.

CYLINDER HEAD

Removal - 1) Remove intake manifold and carburetor as an assembly following procedure given in Intake Manifold Removal. Disconnect exhaust manifold(s) at muffler inlet pipe(s).

2) If left cylinder head is to be removed, unbolt ignition coil. If right cylinder head is being removed, take off alternator. On vehicles equipped with air conditioning, remove compressor mounting bracket bolts and position compressor out of way.

3) Remove cylinder head bolts and lift cylinder head(s) off block assembly. Do not pry between cylinder head and block assembly. Remove and discard old cylinder head gasket.

Installation - 1) Clean cylinder head surface and block gasket surface. If head assembly was removed to replace head gasket, check cylinder head and block surface for flatness. Place new head gasket over dowels in block with word "front" (stamped in gasket) facing forward.

2) Place cylinder head on engine. Oil threads of cylinder head bolts and install bolts. Cylinder head bolts should be tightened in three progressive steps. Torque all bolts in sequence to specifications. If this procedure is followed, cylinder head bolts should not need to be retorqued after extended operation.

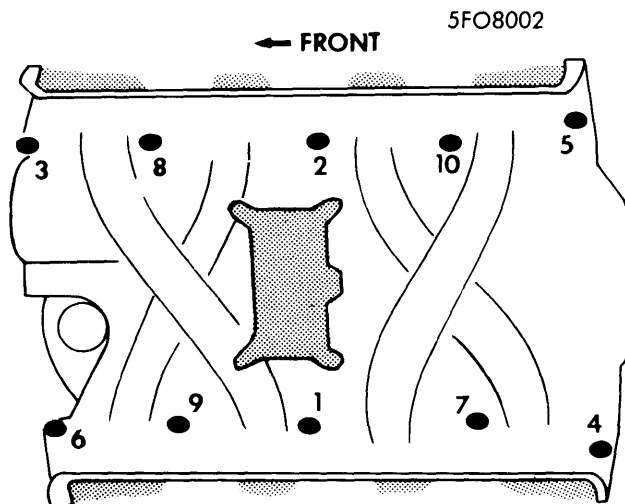

INTAKE MANIFOLD TIGHTENING SEQUENCE

Cylinder Head Tightening Specifications

Step One	Step Two	Step Three
70 ft. lbs.	80 ft. lbs.	90 ft. lbs.

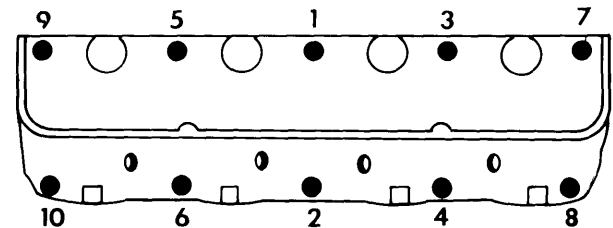

CYLINDER HEAD TIGHTENING SEQUENCE

VALVES							
Engine & Valve	Head Diam.	Face Angle	Seat Angle	Seat Width	Stem Diameter	Stem Clearance	Valve Lift
360" & 390"							
Int.	2.022-2.037"	44°	45°	.060-.080"	.3711-.3718"	.0010-.0027"	.2470"
Exh.	1.551-1.566"	44°	45°	.070-.090"	.3706-.3713"	.0015-.0032"	.2490"

360" & 390" V8 ENGINES (Cont.)

VALVE ARRANGEMENT

E-I-E-I-I-E-I-E — Both banks, front to rear.

VALVE GUIDE SERVICING

Valve guides are integral part of cylinder head. To ream valve guides for installation of valves with oversize stems, always use guide reamers in size sequence and reface valve seat after valve guide is reamed. Reamers are furnished .003" oversize with standard diameter pilot; .015" oversize with .003" oversize pilot; and .030" reamer with .015" oversize pilot. **NOTE** — Use suitable scraper tool to break sharp corner (inside diameter) at top of valve guide after reaming operation is complete.

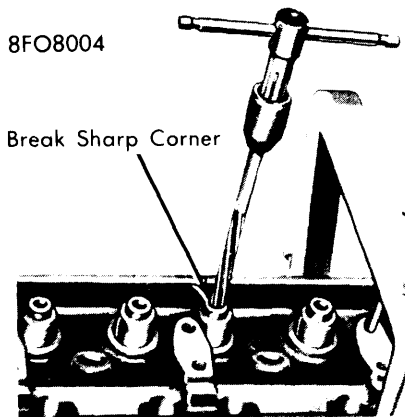

REAMING VALVE GUIDE

VALVE STEM OIL SEALS

Cup or umbrella type seals are used on all valves. Install seals with cup side facing down over valve guide.

VALVE SPRINGS			
Engine	Free Length	PRESSURE (LBS.)	
		Valve Closed	Valve Open
360" & 390"	ⓐ 2.12"	ⓐ 85-95@1.820"	ⓐ 209-231@1.380"

ⓐ — F-100 exhaust is 2.00" free length, 76-84@1.670" closed and 175-194@1.240" open.

VALVE SPRINGS

Removal — 1) Remove air cleaner, crankcase ventilation regulator valve, and any other hoses or electrical wiring. Remove rocker arm cover(s) and spark plug from any cylinder to be serviced.

2) Install air line with adapter into spark plug hole. Remove appropriate rocker arm(s) and push rod(s). **NOTE** — Bring piston in cylinder being serviced up to TDC on compression stroke in order for cylinder to hold air pressure before compressing valve springs. Use suitable spring compression tool to compress valve, remove retainer locks, retainer, valve stem seals and valve spring. **NOTE** — If air pressure fails to hold valve closed, remove cylinder head for inspection of valve seat area, otherwise do not remove air pressure from cylinder as this will allow valve to fall into cylinder if piston has been forced to bottom of cylinder.

Underside of Spring Retainer

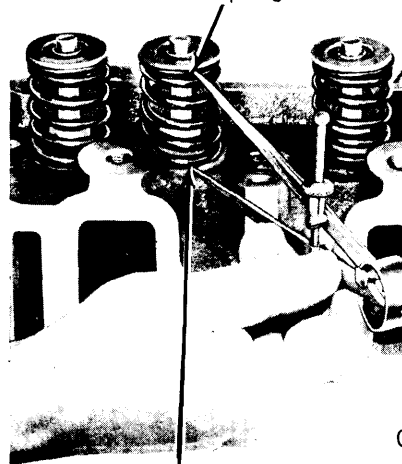

Surface of Spring Pad

CHECKING VALVE SPRING INSTALLED HEIGHT

Installation — 1) Lubricate valve stem with engine oil and install new valve stem seal. Place spring and retainer over valve stem, install retainer locks.

2) Apply Lubriplate or equivalent to ends of push rods and tip of valve stem. Install rocker arms and tighten. Replace all related parts in reverse of removal procedure.

Secure Rocker Arm Tool 6513-J

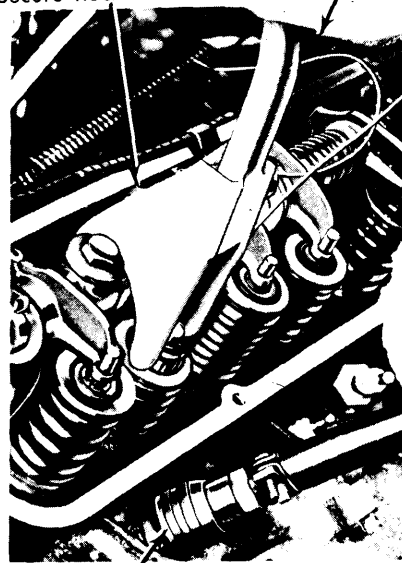

Air Line Adapter

0FO8006

COMPRESSING VALVE SPRING — IN CHASSIS

VALVE SPRING INSTALLED HEIGHT

Valve spring ends must be square within $\frac{5}{64}$ " tolerance. Installed height of valve spring must not exceed specifications. Measure spring height from surface of cylinder head pad to underside of spring retainer. If height is greater than specified, install .030" spacer on pad under spring to bring height within limits. **CAUTION** — Install spacers only if necessary and do not use more than two spacers as any more will overstress valve springs and overload camshaft lobes.

360" & 390" V8 ENGINES (Cont.)

Valve Spring Installed Height Specifications

Application	Installed Height
F100	
Int.	1 ¹³ / ₁₆ - 1 ²⁷ / ₃₂ "
Exh.	1 ² / ₃₂ - 1 ¹ / ₁₆ "
F250/350	
Int. & Exh.	1 ¹³ / ₁₆ - 1 ²⁷ / ₃₂ "

ROCKER ARM ASSEMBLY

Removal & Disassembly - 1) Remove air cleaner, disconnect all spark plug wiring and crankcase ventilation hoses from rocker arm covers. Reposition out of way and remove rocker arm covers.

2) Starting at No. 4 cylinder, loosen rocker arm shaft support bolts two turns at a time in sequence, after all bolts are loosened, remove rocker arm shaft assembly and oil baffle plate. Starting at No. 5 cylinder on left bank, follow same procedure as on right bank. **NOTE** - This method must be followed to avoid damage to valve rocker arm shafts.

3) Remove cotter pins from each end of rocker arm shaft, remove flat washer and spring washer. Slide rocker arms, springs, and supports off shaft. Identify all parts for reinstallation in original location. Remove plugs from ends of shaft.

Reassembly & Installation - 1) Oil all moving parts on rocker arm shaft with engine oil, replace plugs in shaft and install supports, springs, and rocker arms in original positions. Be sure oil holes in rocker arm shaft are facing downward. Replace spring washer, flat washer, and cotter pins on end of shaft.

2) Apply Lubriplate or equivalent to pad end of rocker arms, to tip of valve stems, and to both ends of push rods. Crank engine until No. 1 piston is on TDC at end of compression stroke, then rotate engine an additional 45°.

3) Position baffle plate and valve rocker arm shaft assembly on cylinder heads with valve push rods in place and rocker arm support bolts finger tight. **NOTE** - Be sure shaft is positioned so that oil holes are to the bottom and identification notch on end of rocker arm shaft must be face down and toward front on right bank, or toward the rear on left bank.

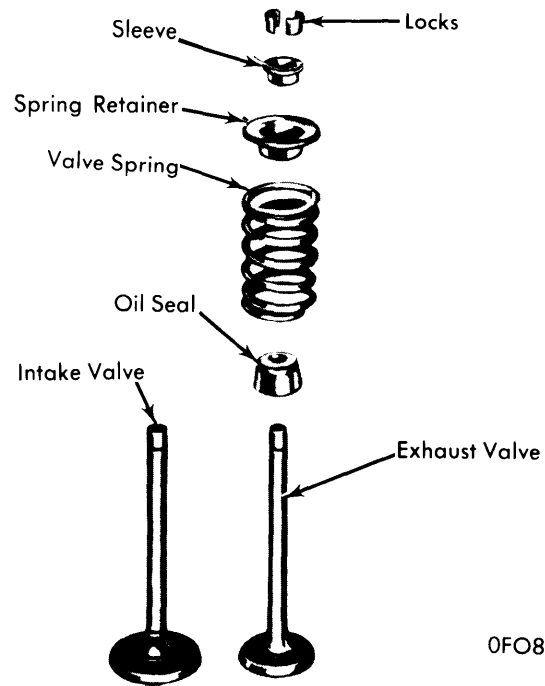

OFO8007

VALVE ASSEMBLIES (TYPICAL)

4) Starting at No. 4 cylinder, tighten rocker shaft support bolts in sequence, two turns at a time, until supports fully contact cylinder head. Torque bolts in sequence to specified amount. Starting at No. 5 cylinder, follow same procedure for left valve rocker shaft support bolts. Procedure given will allow hydraulic lifters to leak down to normal operating positions before engine is cranked, avoiding possibility of damage to valve train assembly.

5) If any part of valve train assembly has been replaced, check for proper clearances and correct if necessary. Clean rocker arm covers and replace rocker arm cover gaskets. Reinstall rocker arm covers and all related wires and hoses.

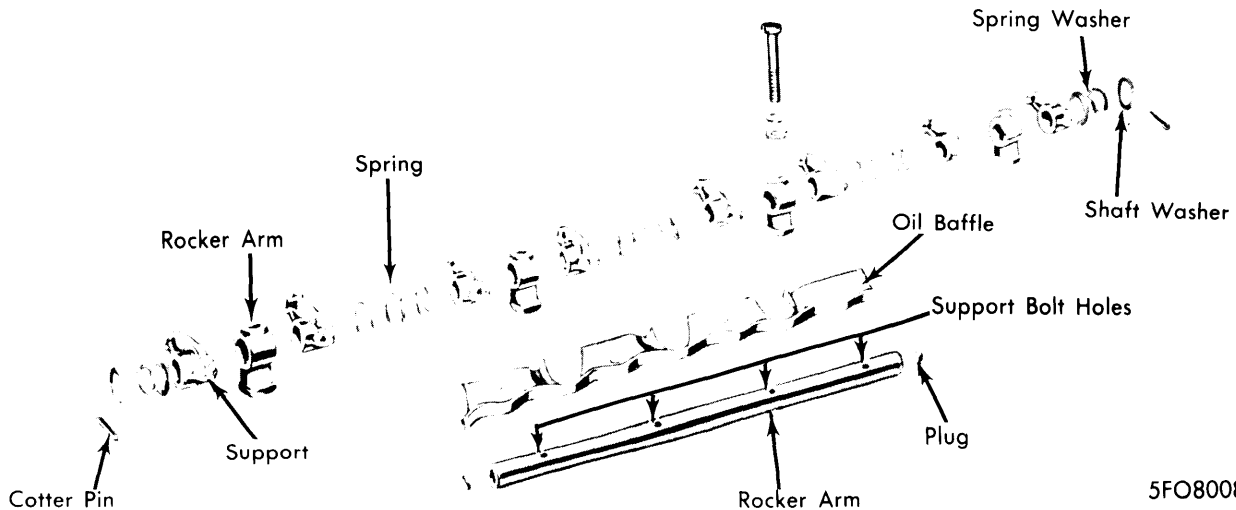

5FO8008

VALVE ROCKER ARM SHAFT ASSEMBLY

Ford Motor Co. V8 Engines

360" & 390" V8 ENGINES (Cont.)

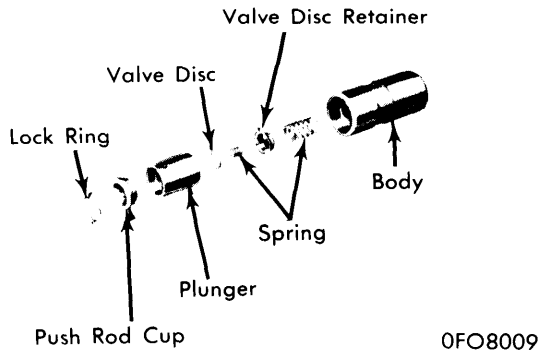

HYDRAULIC VALVE LIFTER ASSEMBLY

plunger travel using suitable leak down rate tester. Replace lifter assembly if any sign of malfunction occurs.

HYDRAULIC VALVE LIFTER ADJUSTMENT

Adjustment is one full turn down on lifter after contact. Clearance can be checked by applying pressure on rocker arm to bleed down lifter (with engine hot). Clearance between valve stem and rocker arm should be .144-.184" (.119-.219" is allowable) with lifter completely bled down and collapsed. Any change from this clearance due to valve train dimensional changes can be compensated for by use of .060" longer or shorter replacement push rods. Clearance is checked using following procedure:

HYDRAULIC VALVE LIFTER ASSEMBLY

Hydraulic valve lifters should be serviced as assemblies only, as internal parts are matched sets and cannot be interchanged. Any lifter removed from engine should be returned to original location. Leak down rate on all lifters is 10-50 seconds at $\frac{1}{16}$ "

- 1) Rotate crankshaft until No. 1 piston is on TDC at end of compression stroke, then check following valves; No. 1, 3, 7, and 8 intakes and No. 1, 4, 5, and 8 exhausts.
- 2) After above valves have been checked, rotate crankshaft 360° (one full revolution) to position No. 6 piston at TDC then check following valves; No. 2, 4, 5, and 6 intakes and No. 2, 3, 6, and 7 exhausts.

PISTONS, PINS, RINGS						
Engine	PISTONS	PINS		RINGS		
	Clearance	Piston Fit	Rod Fit	Rings	End Gap	Side Clearance
360" & 390"	.0015-.0023"	.0001-.0003"	.0002-.0005"	1	.015-.023"	.002-.004"
				2	.010-.020"	.002-.004"
				3	.015-.055"	Snug

OIL PAN

See *Oil Pan Removal* at end of ENGINE Section.

PISTON & ROD ASSEMBLY

Removal - 1) With cylinder head(s) and oil pan removed, use suitable ridge cutter to remove any ridge or deposits on upper end of cylinder bore. **NOTE** - *Piston must be at bottom of stroke. Place shop towel or cloth lightly soaked in oil over piston dome to collect cuttings.*

- 2) Inspect connecting rods and caps for cylinder identification and mark as necessary. Remove rod cap and push piston and rod assembly out of top of cylinder taking care not to nick crankshaft journals or to score cylinder walls.

Installation - 1) Lightly coat cylinder bore, piston and rings with engine oil. Ensure that ring gaps are properly spaced (see illustration) and install ring compressor on piston.

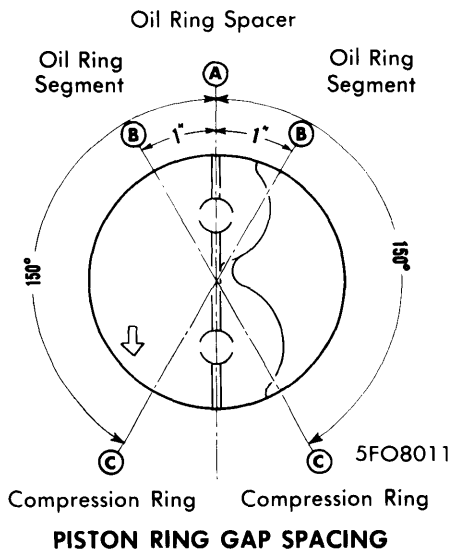

PISTON RING GAP SPACING

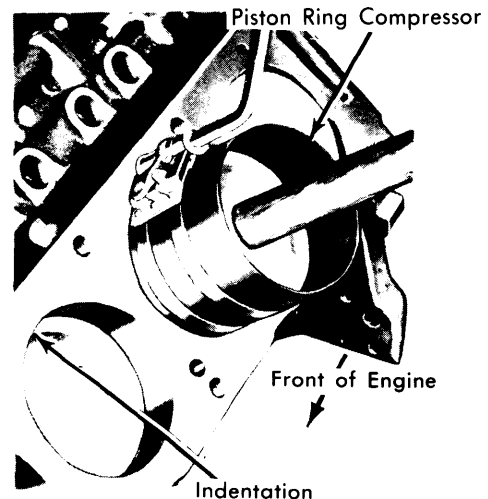

PISTON INSTALLATION (TYPICAL)

360" & 390" V8 ENGINES (Cont.)

2) Install each piston and rod assembly (with identification in piston head toward inside of engine V) in respective bore. Guide connecting rod onto crankshaft journal while tapping piston dome with suitable wooden handle to seat connecting rod against crankshaft. Install rod caps and tighten all nuts and bolts as required.

Measure piston diameter in line with centerline of piston pin and at 90° to piston pin axis. Make sure both piston and cylinder block are at normal room temperature (70°F) when fitting.

PISTON PINS

Removal & Installation — Remove pin retainers, drive pin out of piston and connecting rod using suitable tool (T52P-6135-DAD or equivalent), discard retainers. Perform all cleaning and inspection procedure required. Lubricate all parts with light engine oil. Position connecting rod in piston and push piston pin into place. Insert new pin retainers. **NOTE** — Pin fit should be light thumb press fit at normal temperature (70°F).

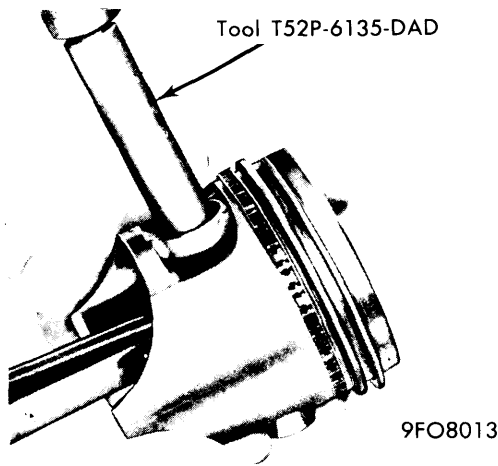

REMOVING PISTON PIN

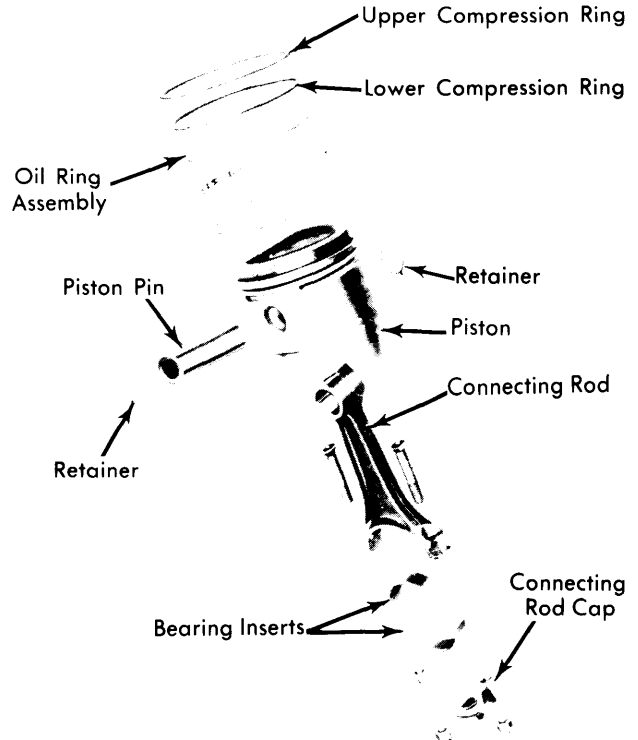

9FO8014

FITTING PISTONS

Calculate size of piston to be used by measuring cylinder bore at right angles to centerline of crankshaft below ring travel.

360" & 390" PISTON, CONNECTING ROD & RELATED PARTS

CRANKSHAFT MAIN & CONNECTING ROD BEARINGS							
Engine	MAIN BEARINGS				CONNECTING ROD BEARINGS		
	Journal Diam.	Clearance	Thrust Bearing	Crankshaft End Play	Journal Diam.	Clearance	Side Play
360" & 390"	2.7484-2.7492"	① .0008-.0015"	No. 3	.004-.010"	2.5907-2.5915"	.0008-.0015"	.010-.02"

① — Allowable clearance is .0008-.0025".

MAIN & CONNECTING ROD BEARINGS

Removal — Remove oil pan and related parts following procedure outlined in Oil Pan Removal. Proceed as follows:

1) To change connecting rod bearings, remove and inspect connecting rod caps for cylinder identification to ensure correct position for replacement. With crankshaft lined up in center of cylinder bore, push piston upward into block enough to allow removal of upper half of bearing.

2) Mark main bearing caps for identification purposes before removing from block assembly. Remove upper half of main bearing by inserting suitable tool (6331-B or equivalent) in oil hole of crankshaft and slowly rotate crankshaft in direction of engine rotation to force out upper half of main bearing.

NOTE — Remove only one bearing at a time leaving other bearings secured until ready to change.

Installation — Thoroughly clean all parts and bearing surfaces and proceed as follows:

1) Determine crankshaft bearing journal clearance using Plastigage method. When checking main bearings, place a jack under counterweight adjoining bearing being checked to avoid weight of crankshaft compressing Plastigage and giving erroneous readings.

2) If bearing clearance is excessive, a .001" or .002" undersize bearing half may be used in combination with a standard size bearing half. If .002" undersize bearings are used on more than one journal, be certain all are installed in cylinder block

360" & 390" V8 ENGINES (Cont.)

side of bearing. If standard and .002" undersized bearing combination did not bring clearance to within specified limits, crankshaft will have to be refinished and suitable undersized bearings installed.

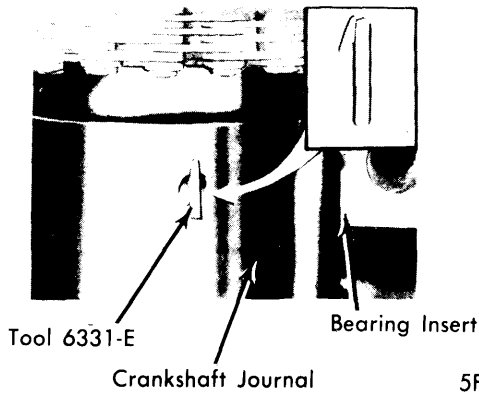

5FO8015

4) To install upper main bearing, lubricate bearing with engine oil and place plain end of bearing over crankshaft on locking tang side of block. Partially insert bearing to allow suitable tool (6331-E or equivalent) to be inserted into oil hole in crankshaft journal. Rotate crankshaft in opposite direction of engine rotation until bearing tang is seated. Remove bearing tool, install bearing cap and tighten. Replace oil pan and all related parts.

THRUST BEARING ALIGNMENT

Install thrust bearing main cap after all other main caps have been tightened. Tighten thrust bearing main cap bolts finger tight. Pry crankshaft forward against thrust surface of upper half of bearing. Hold crankshaft forward and pry thrust bearing cap to rear, this will align thrust surfaces of both halves of bearing. Retain forward pressure on crankshaft and torque main cap bolts to specifications.

UPPER MAIN BEARING REMOVAL OR INSTALLATION

3) After rod bearings have been fitted using Plastigage method, apply light coat of engine oil to journals and bearings. With crankshaft throw to bottom of stroke and upper half of bearing installed, move piston down until connecting rod bearing seats on crankshaft journal. Install connecting rod cap and tighten. Check connecting rod side clearance.

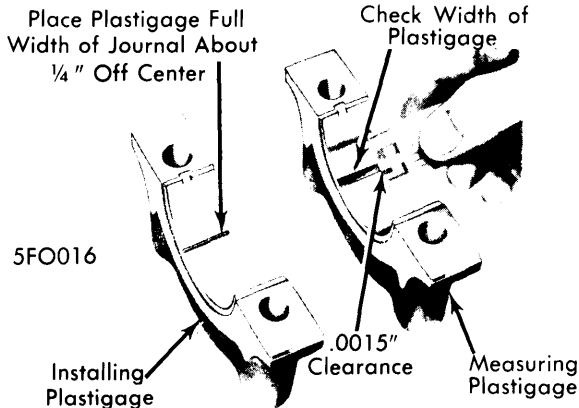

5FO016

INSTALLING & MEASURING PLASTIGAGE - IN CHASSIS

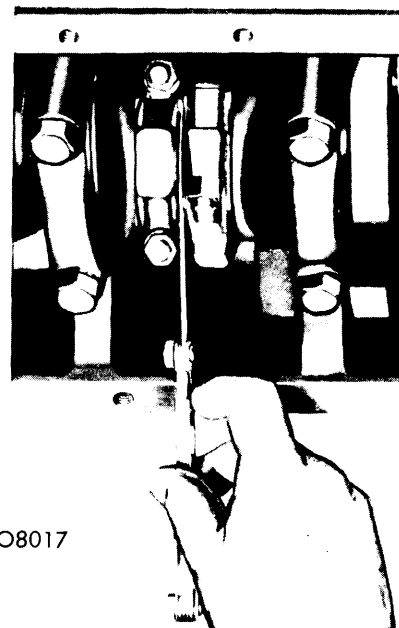

5FO8017

CHECKING CONNECTING ROD SIDE CLEARANCE

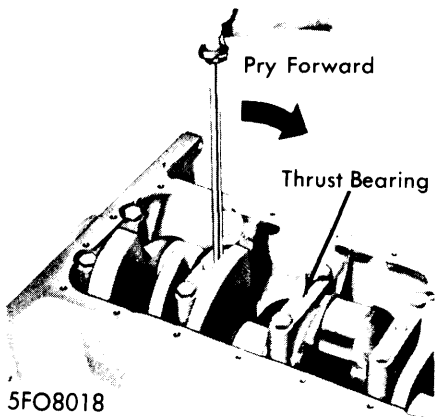

5FO8018

Pry Crankshaft Forward

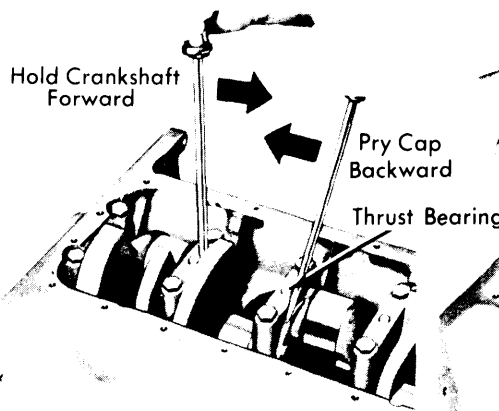

Pry Cap Backward

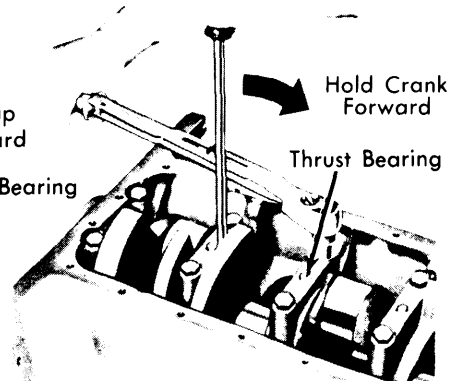

Tighten Cap

THRUST BEARING ALIGNMENT

360" & 390" V8 ENGINES (Cont.)

REAR MAIN BEARING OIL SEAL

Removal — Remove oil pan, and oil pump if required. Loosen all main bearing cap bolts to allow crankshaft to be lowered slightly, but not to exceed $\frac{1}{32}$ ". Remove rear main bearing cap and remove oil seal from bearing cap and block. On block half of seal, install small sheet metal screw in one end of seal and pull on screw to remove seal from block. Avoid scratching or damaging seal surfaces on block.

Installation — 1) Clean oil seal groove, dip seal halves in clean engine oil. Carefully install upper seal into groove with lip side of seal toward front of engine, rotating seal on journal of crankshaft until approximately $\frac{3}{8}$ " of seal protrudes below parting surface. **CAUTION** — Avoid shaving any rubber from outside diameter of seal by bottom edge of groove. Do not allow any oil to get into sealing area.

2) Tighten remaining bearing cap bolts to torque specifications. Install lower seal in rear main bearing cap with undercut side of seal toward front of engine, allowing seal to protrude approximately $\frac{3}{8}$ " above parting surface to mate with upper seal when cap is installed.

3) Apply suitable oil-resistant sealer to bearing edges and install rear main bearing cap. Torque cap bolts to specifications and reinstall oil pan, oil pump (if required) and all other related parts.

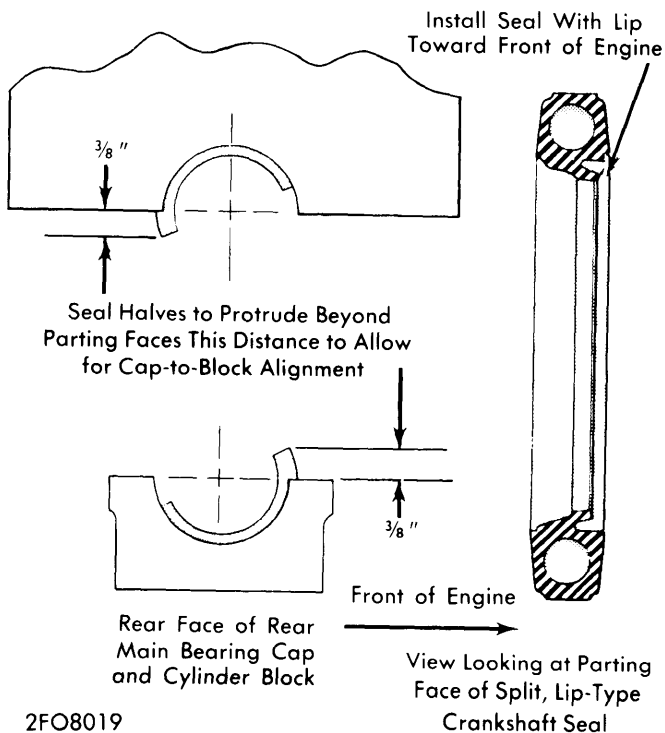

INSTALLING CRANKSHAFT REAR MAIN SEAL

ENGINE FRONT COVER

Removal — Drain cooling system and crankcase. Remove fan, spacer and all hoses or brackets attaching to water pump. Remove crankshaft pulley and use suitable puller tool to remove crankshaft damper. Disconnect fuel pump outlet line from fuel pump, remove bolts and move fuel pump to one side.

Remove crankshaft sleeve. Remove front cover bolts and cut oil pan gasket flush with face of cylinder block. Remove engine front cover and all related parts as necessary.

Installation — Clean all gasket surfaces. Use suitable sealer and install gaskets and seals. Use suitable tool to center front cover on crankshaft. Install bolts and tighten. Inspect crankshaft sleeve for nicks, grooves or burrs, replace or repair as necessary, coat crankshaft sleeve with grease and install. Place damper on crankshaft, tighten to specifications. Install all related parts.

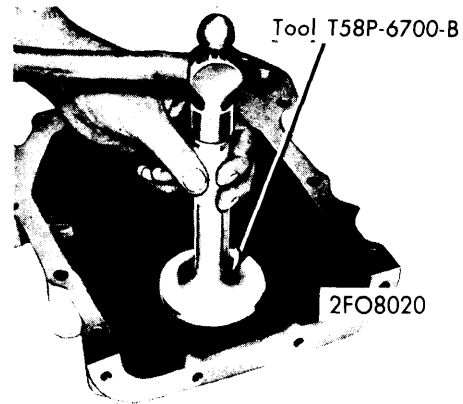

INSTALLING FRONT OIL SEAL

FRONT COVER OIL SEAL

Removal — Follow procedure given in Front Cover Removal. Using suitable pin punch, drive out old seal. Take care not to damage sealing surface.

Installation — Coat seal with grease and drive into front cover using suitable tool (T58P-6700-B or equivalent). Check seal to make sure that all edges are fully seated and spring is properly positioned in seal. Reassemble in reverse order of removal.

CAMSHAFT			
Engine	Journal Diam.	Clearance	Lobe Lift
360" & 390"	2.1238-2.1248"	.001-.003"	Int. ① .2470" Exh. ② .2490"

① — Theoretical valve lift is .4273".

② — Theoretical valve lift is .4308".

TIMING CHAIN

Removal & Installation — Remove front cover following procedure given in Front Cover Removal. Crank engine until timing marks are positioned properly (see illustration). Remove camshaft sprocket cap screw, washer, and fuel pump eccentric. Slide both sprockets and timing chain forward off key ways and remove as an assembly. To install, position timing chain on sprockets with timing marks aligned (see illustration). Slide timing chain and sprockets onto crankshaft and camshaft as an assembly. Install fuel pump eccentric, washer, and sprocket cap screw. Tighten cap screw and oil timing chain. Reassemble in reverse order of removal.

360" & 390" V8 ENGINES (Cont.)

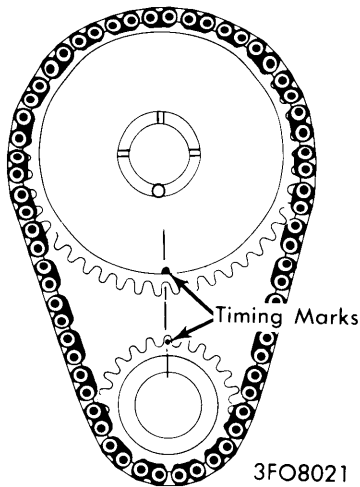

ALIGNING TIMING MARKS

CAMSHAFT

Removal — 1) Drain cooling system, remove radiator and grille assembly. Remove engine front cover and related parts. Remove valve covers, loosen rocker arms to allow removal of push rods and valve lifters. **NOTE** — Keep push rods and valve lifters in sequential order to return to original locations.

2) Remove thrust plate and carefully pull camshaft out through front of engine. **CAUTION** — Do not scar or mark camshaft lobes or bearing journals while removing camshaft. Check camshaft for signs of excessive wear or fatigue, replace if necessary.

Installation — Oil camshaft journals with engine oil and apply Lubriplate (or equivalent) to camshaft lobes. Carefully slide camshaft through bearings and install camshaft thrust plate. Position sprockets and timing chain on camshaft with timing marks aligned on sprockets (see illustration). Reverse removal procedure to install all related parts to complete installation.

CAMSHAFT BEARINGS

Removal & Installation — **NOTE** — Camshaft bearings are not interchangeable from one bore to another. Remove camshaft, flywheel and crankshaft. Push pistons to top of cylinders. Remove camshaft rear bearing bore plug and remove camshaft bearings using suitable tool. Fit new cam bearings into cylinder block using suitable cam bearing installing tool. Make sure oil holes are properly aligned in each journal. Be sure front bearing is installed to specific distance (.005-.020") below front face of cylinder block.

CAMSHAFT END THRUST

CAUTION — Prying against aluminum-nylon camshaft sprocket with valve train load on camshaft can break or damage sprocket. Rocker arm and shaft assembly must be loosened sufficiently to free camshaft. Push camshaft toward rear of engine. Install dial indicator so that indicator point is on camshaft sprocket attaching screw. Zero dial indicator.

Position large screwdriver between camshaft gear and block assembly. Pull camshaft forward and release. Compare dial indicator reading with specifications. If end play is excessive, check camshaft spacer for correct installation. If spacer is correctly installed, replace thrust plate. Remove dial indicator.

CAM LOBE LIFT

Check lift of each camshaft lobe in consecutive order as follows:

1) Remove all rocker arms. Make sure each push rod is in valve lifter socket. Install dial indicator allowing ball socket adapter of dial indicator to rest on end of push rod in same plane as push rod movement.

2) Using remote starter switch (with ignition switch in "OFF" position), turn engine until valve lifter being checked is on base circle of camshaft lobe, indicating lowest point of push rod travel.

3) Zero dial indicator and continue to rotate engine until push rod is in fully raised position, giving highest indicator reading. Continue same procedure for each camshaft lobe. Compare camshaft lift taken from dial indicator readings with specifications.

4) To check accuracy of dial indicator readings, continue to rotate engine until dial indicator reads zero. If lift on any camshaft lobe is .005" less than specifications, valve lifters are operating on worn camshaft lobes indicating need for camshaft replacement.

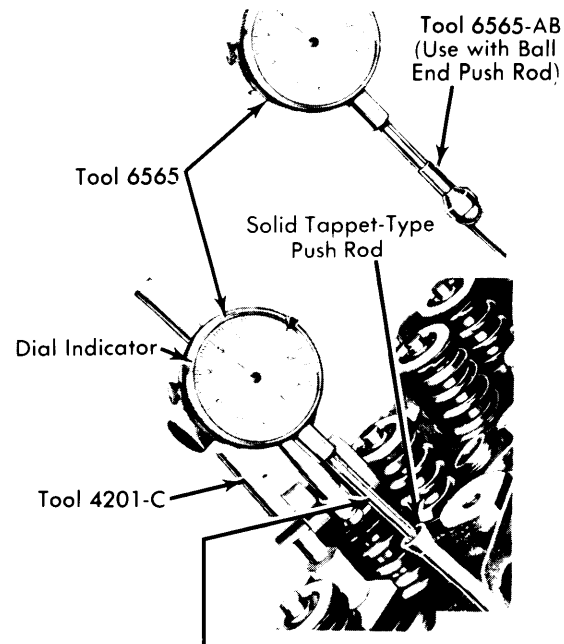

Be Sure to Place Indicator Tip in Center of Push Rod Socket

5FO8023

CHECKING CAMSHAFT LOBE LIFT

360" & 390" V8 ENGINES (Cont.)

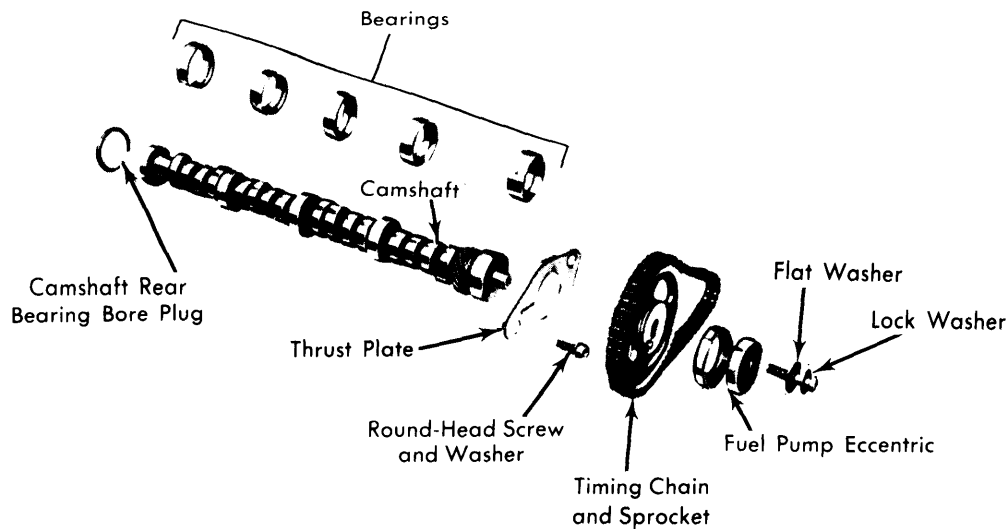

9FO8022

CAMSHAFT AND RELATED PARTS

ENGINE OILING

Crankcase Capacity — All engines, 5 quarts of oil. Add one quart when changing filter.

Oil Filter — Replace at first oil change and at every second oil change following.

Normal Oil Pressure — All engines carry 35-65 psi at 2000 RPM with engine at normal operating temperature.

Pressure Regulator Valve — Housed in oil pump body, nonadjustable.

ENGINE OILING SYSTEM

Oil is taken from oil pan sump at front of engine and forced through pressure-type lubrication system of engine by a rotor-type oil pump. Oil passes through full flow oil filter before entering into engine where oil flows into main oil gallery which is located in center of valve push rod chamber floor. Oil gallery supplies oil to each individual camshaft bearing through drilled passages in block. Oil moves from camshaft bearings via drilled passages to each main crankshaft bearing, oil flows through notches or grooves in main bearings to lubricate crankshaft journals. Oil is sprayed onto timing chain and crankshaft sprockets from drain behind camshaft sprocket. Crankshaft is drilled from main bearings to connecting rod bearings to provide lubrication to rods. A groove in connecting rod cap squirts oil onto cylinder walls for internal oiling. Oil passages are drilled from main oil gallery to valve lifter assemblies. Another drilled passage moves oil from No. 2 camshaft bearing web to left cylinder head between No. 5 and No. 6 cylinders to lubricate valve rocker arm shaft assembly. Oil flows through valve rocker arm shaft to drilled holes in each rocker arm to lubricated bushing and both ends of rocker arm, excess oil spirals down rotating push rods and lubricates push rod seats. Right side rocker arm shaft is similarly oiled by No. 4 camshaft bearing through No. 3 rocker arm shaft support. Excess oil is returned to oil pan by way of drains located in each end of cylinder heads and in push rod chamber floor.

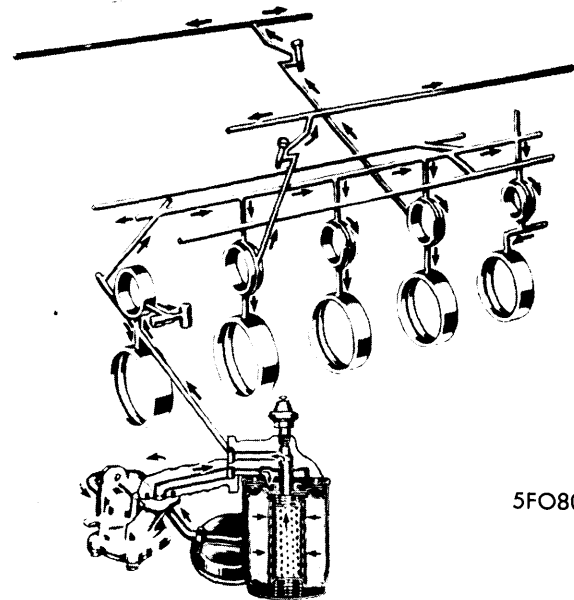

5FO8024

ENGINE OILING SYSTEM

OIL PUMP

Removal & Disassembly — Remove oil pan, remove attaching bolts and oil pump from engine. Remove oil inlet tube, cover attaching screws and cover. Remove inner rotor and shaft assembly, remove outer race. Drill small hole into oil pressure relief spring valve chamber cap. Insert small self-threading sheet metal screw into cap and pull from chamber, remove spring and plunger.

Inspection & Reassembly — Clean, inspect and oil all parts thoroughly. Install outer race and inner rotor and shaft assembly (see specifications for clearances). **NOTE** — Identification mark (dimple) on outer race must face outward and

360" & 390" V8 ENGINES (Cont.)

ENGINE OILING (Cont.)

toward same side as identification mark on rotor. Rotor and shaft assembly and outer race are serviced as an assembly, one part cannot be replaced without replacing other part. Install cover and tighten cover bolts. Position oil inlet tube on oil pump, install new gasket and tighten attaching bolts. Prime oil pump by submerging inlet port in oil and rotating shaft until oil flows from outer port.

Oil Pump Specifications

Relief Valve Spring Tension	
All Engines.....	8.7-9.5 lbs. @1.560"
Shaft-to-Housing Clearance	
All Engines.....	.0015-.0029"
Relief Valve Clearance	
All Engines.....	.0015-.0029"
Rotor Assembly End Clearance	
All Engines.....	.001-.004"
Outer Race-to-Housing Clearance	
All Engines.....	.001-.003"

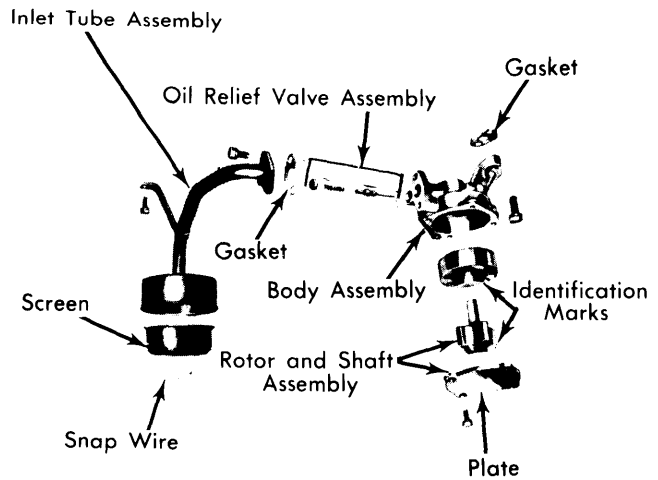

2FO8025

OIL PUMP (DISASSEMBLED)

TIGHTENING SPECIFICATIONS (FT. LBS.)

Cylinder Heads.....	①80-90
Oil Pan.....	8-10
Intake Manifold.....	40-45
Exhaust Manifold.....	18-24
Flywheel-to-Crankshaft.....	75-85
Main Bearing Caps.....	95-105
Connecting Rod Caps.....	40-45
Engine Front Cover.....	10-15
Camshaft Sprocket.....	45-57
Oil Pump Cover.....	9-14
Rocker Arm Shaft Bolts.....	40-45
Damper-to-Crankshaft.....	130-150
Valve Rocker Arm Cover.....	4-7

① — Three step procedure. See Cylinder Head Tightening.