

Clutches

1965-74 GENERAL MOTORS

DESCRIPTION

Chevrolet and GMC vehicles incorporate two types of clutches. Borg & Beck type clutches can be identified by the use of three release levers to provide pressure plate actuation, and by coil springs which provide pressure plate tension. Diaphragm Spring type clutches utilize a single, slotted diaphragm type spring to provide both pressure plate actuation and tension. Both hydraulic and mechanical linkage are used for clutch control from 1965-70. Only mechanical linkage is used after 1970. Removal and installation procedures, overhaul procedures, and adjustments are the same for both Chevrolet and GMC during a given year, and are similar for both types of clutches used.

REMOVAL & INSTALLATION

CLUTCH

Removal & Installation — Raise and support vehicle under frame, and remove transmission. See *General Motors Manual Transmission Removal in this Section*. Disconnect clutch fork return spring, and clutch fork push rod at clutch fork. Remove clutch release bearing from clutch fork, and remove clutch fork from clutch housing. Mark clutch cover assembly and flywheel for reassembly reference, then install suitable clutch support tool (J-5824). Loosen clutch cover attaching bolts alternately and evenly until all spring tension is relieved, then remove bolts, support tool, and clutch assembly. To install, reverse removal procedure, making sure clutch hub and pilot bearing are aligned.

CLUTCH MASTER CYLINDER

NOTE — Two types of master cylinders are used on vehicles equipped with hydraulic brake controls; Double-barrel, and Single-barrel, horizontal master cylinders. Removal and installation procedures are similar for both master cylinders.

Removal & Installation — Remove clutch pedal return spring, and disconnect clutch master cylinder push rod at clutch pedal (disconnect both clutch and brake pedal push rods on vehicles equipped with double-barrel master cylinder). Disconnect hydraulic line(s) at master cylinder, and remove master cylinder attaching bolts. Remove master cylinder from vehicle, remove cover, and drain fluid from master cylinder. To install, reverse removal procedure, and bleed system. See *Hydraulic System Bleeding*. **CAUTION** — On vehicles equipped with double-barrel master cylinder, it will be necessary to bleed both clutch and brake hydraulic systems (also see *Hydraulic Brake Bleeding in BRAKE SYSTEMS Section*).

CLUTCH SLAVE CYLINDER

Removal & Installation — Clean outside of cylinder thoroughly, and remove clutch fork return spring. Disconnect hydraulic line at slave cylinder, and remove slave cylinder attaching bolts. Remove cylinder from vehicle. To install, reverse removal procedure, and bleed system. See *Hydraulic System Bleeding*.

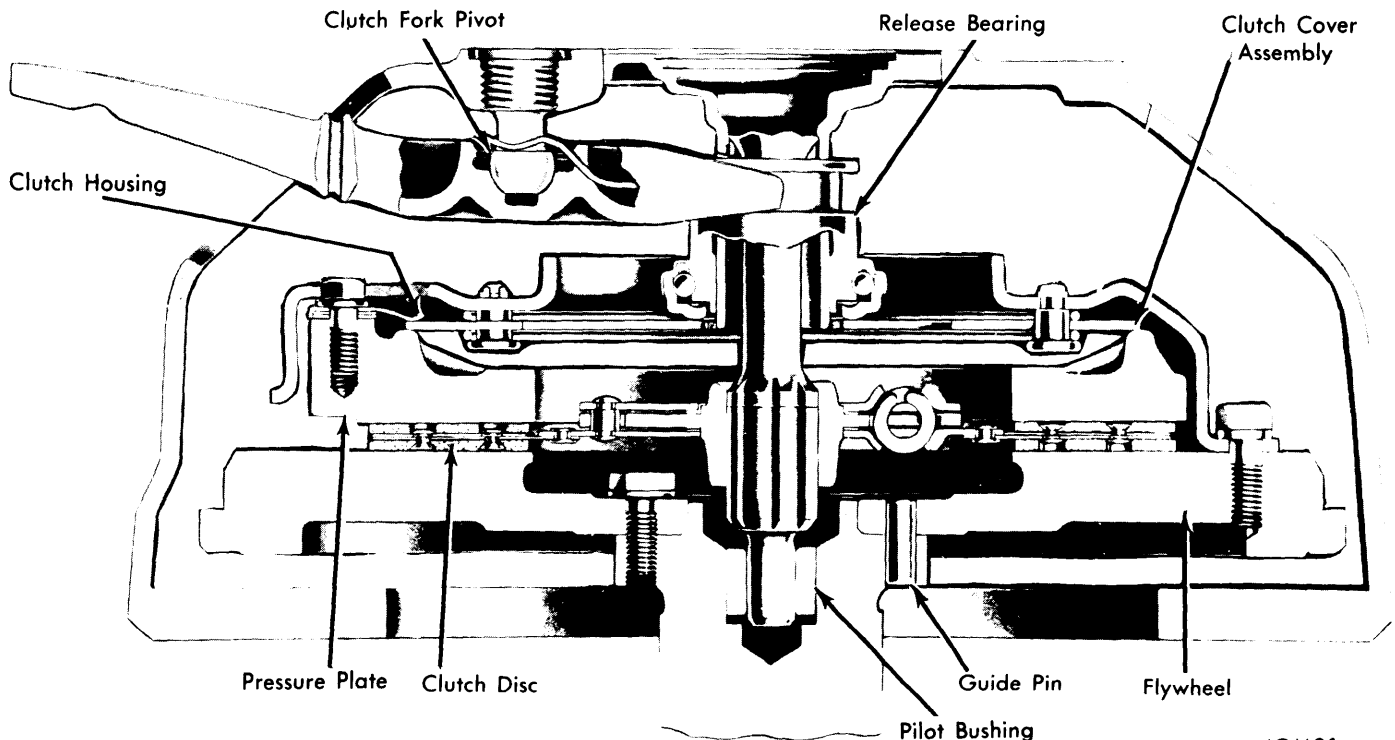

CLUTCH ASSEMBLY (TYPICAL)

4GM01

1965-74 GENERAL MOTORS (Cont.)

OVERHAUL

CLUTCH MASTER CYLINDER

NOTE — Overhaul procedure covers single-barrel master cylinder, and clutch side of double-barrel master cylinder only.

Disassembly & Reassembly — With master cylinder removed from vehicle, remove dust boot, snap ring, and piston stop plate from end of cylinder. Remove piston and spring from cylinder bore, and inspect cylinder for damage. If excessive pitting or scoring is apparent, replace cylinder assembly. To reassemble, reverse disassembly procedure using new rubber parts.

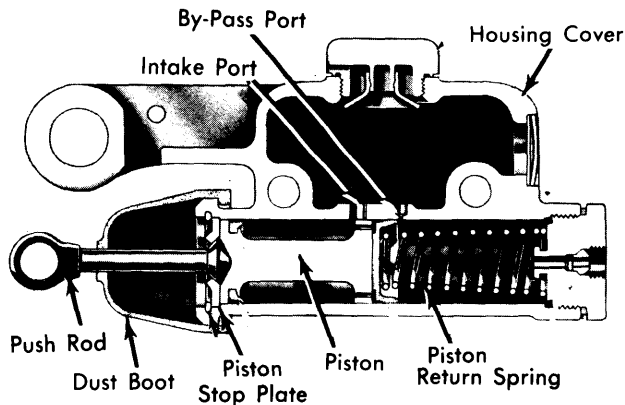

4GM04

MASTER CYLINDER ASSEMBLY (TYPICAL)

CLUTCH SLAVE CYLINDER

Disassembly & Reassembly — With slave cylinder removed from vehicle, remove dust boot and piston retaining ring. Remove piston and cup from cylinder bore. Inspect cylinder for signs of excessive wear and damage. Light scratches may be removed by honing cylinder bore, providing piston-to-bore clearance does not exceed .004". To reassemble cylinder, reverse disassembly procedure using new rubber parts.

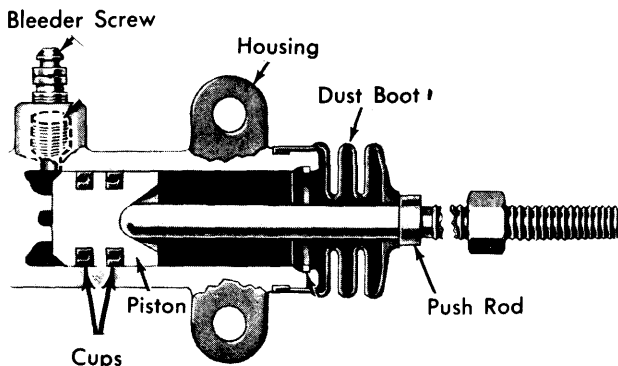

4GM03

SLAVE CYLINDER ASSEMBLY

ADJUSTMENT

CLUTCH LINKAGE

Pedal Height — "G" Models Only (1965-70) — Adjust clutch pedal stop bolt, located on clutch pedal arm below floorboard, until clutch pedal is at same height as brake pedal.

Total Travel — Hydraulic Linkage Only (1965-70) — Disconnect clutch fork return spring at fork, and force fork push rod into slave cylinder until piston is bottomed in bore. Push clutch fork toward rear until release bearing just contacts clutch release levers. Adjust clearance between "V" block on push rod and clutch fork to $\frac{3}{16}$ ".

Free Travel — Hydraulic Linkage (1965-70) — Shorten or lengthen master cylinder push rod as necessary to obtain correct clutch pedal free travel, as measured at center of pedal pad.

Application	Hydraulic Clutch Free Travel	Travel
All Models (1965-68)		$\frac{1}{8}$ "
All Models (1969-70)		$\frac{1}{4}$ "

Free Travel — Mechanical Linkage (1965-72) — Disconnect clutch fork return spring at clutch fork. Loosen clutch fork swivel lock nut, and force push rod toward rear until clutch release bearing just contacts clutch release levers. Turn push rod adjusting nut to provide $\frac{3}{16}$ - $\frac{1}{4}$ " clearance between nut and swivel. Tighten clutch fork swivel lock nut, and check pedal free travel.

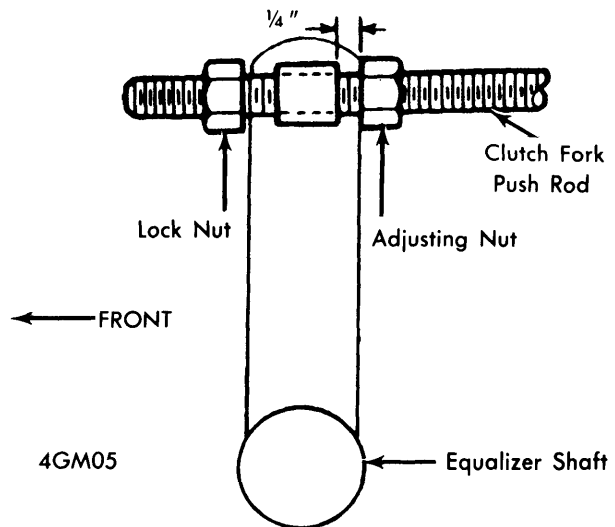

4GM05

FREE TRAVEL ADJUSTMENT (1965-72)

Free Travel — "G" Models (1973-74) — Disconnect clutch fork return spring at clutch fork. Loosen clutch fork swivel lock nut, and force push rod toward rear until clutch release bearing just contacts clutch release levers. Turn push rod adjusting nut to provide $\frac{3}{16}$ - $\frac{1}{4}$ " clearance between nut and swivel. Tighten clutch fork swivel lock nut, and check pedal free travel.

Clutches

1965-74 GENERAL MOTORS (Cont.)

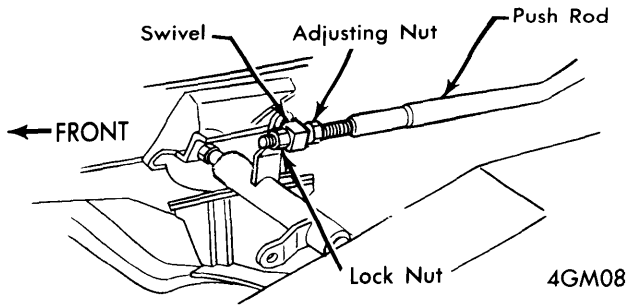

FREE TRAVEL ADJUSTMENT ("G" MODELS)

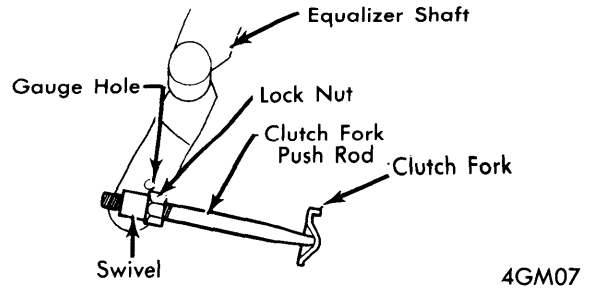

FREE TRAVEL ADJUSTMENT ("P" MODELS)

Free Travel - P30 MHC (1973-74) - Disconnect clutch pedal return spring, and loosen clutch swivel lock nut. Move clutch fork toward rear until release bearing just contacts clutch release levers. Rotate clutch equalizer shaft until clutch pedal is seated against pedal stop. Turn clutch fork push rod in swivel to obtain $\frac{1}{4}$ - $\frac{3}{16}$ " clearance between adjustment nut and shoulder on clutch fork push rod. Tighten swivel lock nut, and check pedal free travel.

CLUTCH RELEASE LEVERS

Borg & Beck Type Only - Place suitable gauge plate (J-1048) on flywheel in position normally occupied by clutch disc. Install clutch cover assembly over gauge plate, with release levers over machined lands of gauge plate. Depress release levers several times to fully seat levers in operating position. Using suitable gauging tool (J-6456), measure distance from hub of gauge plate to end of release lever. To adjust, turn adjusting nut until lever reaches proper height, then stake adjusting nut using a dull punch.

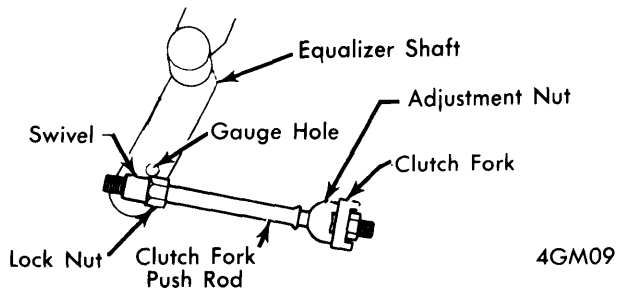

FREE TRAVEL ADJUSTMENT (P30 MHC)

Free Travel - All Other Models (1973-74) - Disconnect clutch pedal return spring at clutch fork. Rotate clutch equalizer shaft until clutch pedal is seated against pedal stop. Force clutch fork push rod toward rear until release bearing just contacts clutch release levers. Loosen clutch swivel lock nut, and adjust swivel until swivel can be easily inserted in gauge hole of equalizer shaft. Remove swivel from gauge hole, and install in equalizer shaft lower hole. Tighten swivel lock nut and check pedal free travel.

Mechanical Clutch Free Travel

Application	Travel
1965-72 (All Models).....	$\frac{3}{4}$ - 1"
1973-74	
"C" & "K" Models	$1\frac{3}{8}$ - $1\frac{5}{8}$ "
"G" Models.....	$\frac{3}{4}$ - 1"
P30 MHC	$1\frac{3}{8}$ - $1\frac{5}{8}$ "
All Other Models.....	$1\frac{1}{4}$ - $1\frac{1}{2}$ "

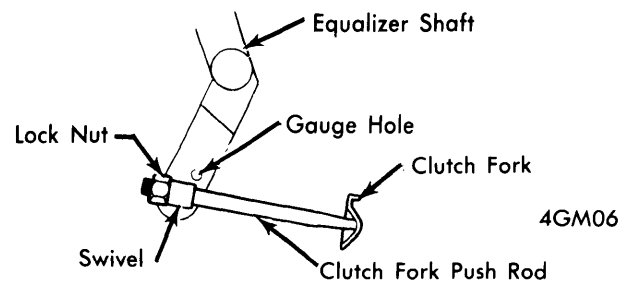

FREE TRAVEL ADJUSTMENT ("C" & "K" MODELS)

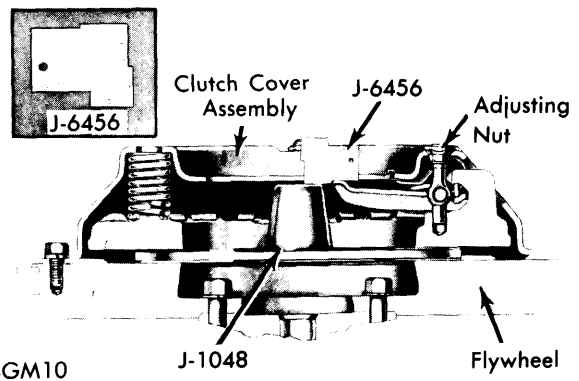

RELEASE LEVER ADJUSTMENT

HYDRAULIC SYSTEM BLEEDING

Pressure Bleeding - Clean bleeder screw on slave cylinder, and attach bleeder hose to screw. Submerge free end of bleeder hose in jar $\frac{1}{2}$ full of clean brake fluid. Pressurize clutch master cylinder to 30 lbs., and open and close bleeder screw at four second intervals until no air appears in fluid running from bleeder hose.

1965-74 GENERAL MOTORS (Cont.)

Manual Bleeding — Fill clutch master cylinder with clean brake fluid. Pump clutch pedal four or five times, and hold pedal at bottom of last stroke. Open bleeder screw on slave cylinder ½ turn until fluid and air stop flowing from hose. Close bleeder, then release pedal. Repeat procedure until all air is expelled from system.

TIGHTENING SPECIFICATIONS	
Application	Ft. Lbs.
Clutch Cover-to-Flywheel Bolts	35
Clutch Housing-to-Engine Block Bolts	30
Transmission-to-Clutch Housing	55

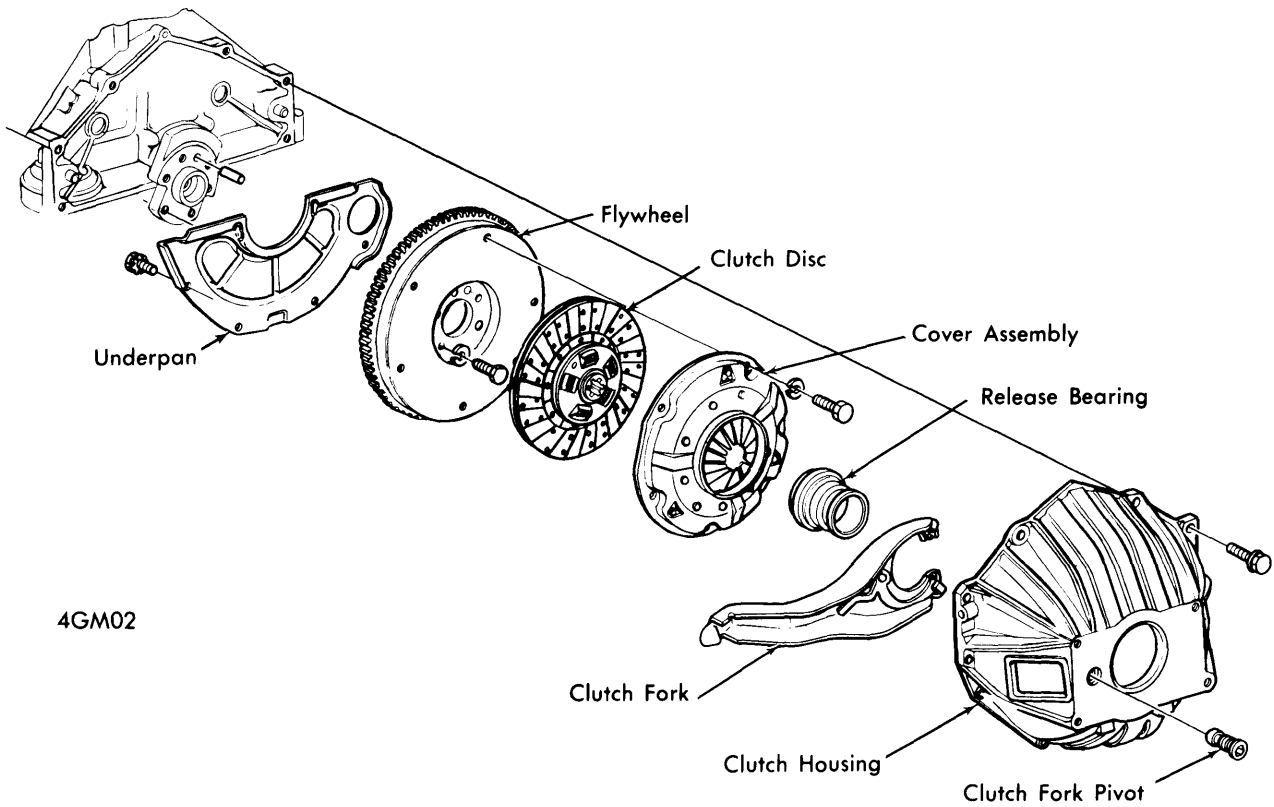

4GM02

CLUTCH ASSEMBLY — EXPLODED VIEW (TYPICAL)