

## 1973-74 400" 8 ENGINE

GENERAL SPECIFICATIONS							
Year	Displ. Cu. Ins.	Carburetor	HP at RPM	Torque (Ft. Lbs. at RPM)	Compr. Ratio	Bore	Stroke
1973	401"	2-Bbl.	211@4000	326@4000	8.25:1	4.165"	3.68"
1974	401"	2-Bbl.	211@4000	326@4000	8.25:1	4.165"	3.68"

► **NET HORSEPOWER & TORQUE NOTE** — Horsepower and Torque figures given for 1972 and later are NET. NET Horsepower and Torque represent power at the flywheel when the engine is installed in the vehicle, with wide open throttle and all systems operating such as; air cleaner, exhaust system, water pump, generator, oil pump and air conditioning.

### ENGINE IDENTIFICATION

Engine Identification Number is located on a metal tag attached to front of right valve cover. The fifth digit (a letter) indicates displacement.

**Application** **Digit**  
 400" ..... V

### ENGINE REMOVAL

See Engine Removal at end of ENGINE Section.

### INTAKE MANIFOLD

**Removal** — 1) Drain cooling system and remove air cleaner. Disconnect spark plug wires from spark plugs and remove spark plug wire brackets. Disconnect upper radiator hose and by-pass hose from intake manifold.

2) Disconnect coil bracket and lay coil and bracket off to side. Disconnect all hoses, lines, linkage, and wires from carburetor and intake manifold. Disconnect air distribution hoses to A.I.R. manifolds. Disconnect A.I.R. diverter valve from pump and lay valve and hoses off to side. Remove carburetor, manifold and gaskets.

**Installation** — Make sure all gaskets surfaces are clean. Apply sealer to new gaskets and seals. Position gaskets and seals and install intake manifold. Tighten bolts evenly from center. To install remaining components, reverse removal procedure.

kets. Remove rocker arm retaining nuts, pivot balls, rocker arms and push rods. Mark or identify push rods and rocker arms to ensure that they are installed in original position.

2) Remove exhaust manifolds and loosen all drive belts. If right cylinder head is being removed, remove air conditioning compressor and bracket (if equipped). Disconnect battery negative cable and alternator support bracket from cylinder head.

3) If left cylinder head is being removed, disconnect A.I.R. pump and power steering pump bracket (if equipped). Remove cylinder head retaining bolts and remove cylinder heads and gaskets.

**Installation** — Make sure gasket surfaces are clean. Apply sealer to both sides of head gasket and place in position. Install cylinder heads and tighten bolts in sequence shown in illustration. To complete installation, reverse removal procedure.

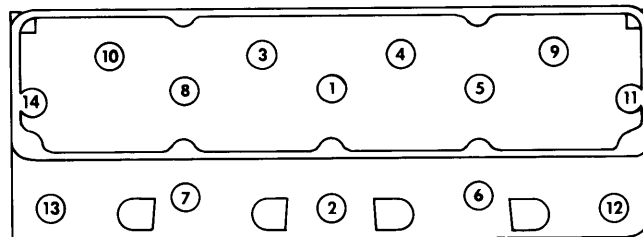

4IH01

### CYLINDER HEAD TIGHTENING SEQUENCE

### CYLINDER HEAD

**Removal** — 1) Drain cooling system and remove intake manifold as previously outlined. Remove valve covers and gas-

VALVES							
Engine & Valve	Head Diam.	Face Angle	Seat Angle	Seat Width	Stem Diameter	Stem Clearance	Valve Lift
1973-74 400"	Int.	.....	29°	30°	.040-.060"	.3715-.3725"	.001-.003"
	Exh.	.....	44°	45°	.040-.060"	.3715-.3725"	.001-.003"

### VALVE ARRANGEMENT

E-I-I-E-E-I-I-E (Both banks, front to rear.)

### VALVE GUIDE SERVICING

Valve guides are integral with cylinder head. If valve stem to guide clearance is excessive, valves with oversize stems are

available. Valves are available with stems .003", .015" and .030" oversize. Use a reamer of appropriate size to ream guides for correct clearance with oversize valve stems.

### VALVE STEM OIL SEALS

An umbrella type oil seal is installed on each valve stem before valve spring is installed. See Valve Springs.

# IHC V8 Engines

## 1973-74 400" 8 ENGINE (Cont.)

VALVE SPRINGS			
Engine	Free Length	PRESSURE (LBS.)	
		Valve Closed	Valve Open
1973-74 400"	Int.	2.200"	.....
	Exh.	2.000"	.....

**Removal** – With cylinder head removed, compress valve spring with a suitable valve spring compressor. Remove valve keepers and release spring compressor. Remove spring, retainer, spring seat or rotator (if equipped).

**Installation** – Check valve spring in a suitable spring tester. Intake valve should read 210 to 226 lbs. when compressed to 1.365". Exhaust valve should read 210 to 226 lbs. when compressed to 1.183". To install valve springs, reverse removal procedure. Install umbrella type valve stem oil seal on valve stem before installing valve springs.

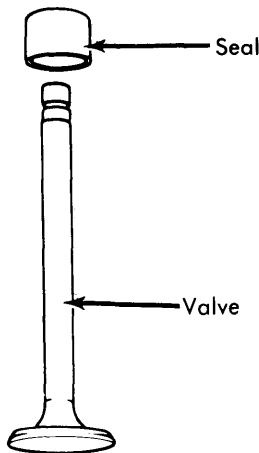
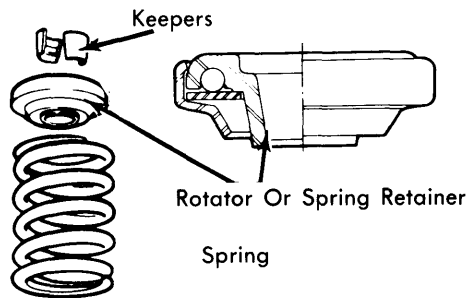

VALVE & SPRING ASSEMBLY

### ROCKER ARM ASSEMBLY

With valve cover removed, remove rocker arm retaining nut and pivot balls. Remove rocker arms and push rods. Mark or identify rocker arms to ensure that they are installed in original position. Check valve contact surface on rocker arm for wear or scuffing and replace as necessary. Inspect each push rod end for wear or scuffing. If push rod must be replaced because of damage, corresponding valve lifter must be replaced. To install rocker arm assembly, reverse removal procedure.

### HYDRAULIC VALVE LIFTER ASSEMBLY

**Removal** – Remove intake manifold as previously outlined. Remove valve covers, rocker arms and push rods as previously outlined. Pull lifters out of bore in cylinder block, mark or identify lifters to ensure that they are installed in original position.

**Disassembly** – Place lifter upside down for approximately five minutes to drain out excess oil. Using a push rod, press down on push rod seat and remove retainer at top of lifter. Shake assembly gently to remove plunger. If plunger will not release, tap lifter gently on upper edge to remove plunger. Take care not to lose check valve components on bottom of plunger.

**Assembly** – Clean all components in a suitable cleaning solution. Check all components for wear or damage. Replace complete lifter if any components are worn or damaged. Fill lifter body  $\frac{1}{3}$  full of kerosene and prelubricate all other components with kerosene. Reverse disassembly procedure to assemble lifter. Check lifter in a suitable leakdown tester (Tester No. SE-1893). Correct leakdown rate is  $\frac{1}{8}$ " travel at 50 pounds in 20 to 110 seconds.

**Installation** – To install hydraulic valve lifters, lubricate with oil and reverse removal procedure. Make sure lifters are installed in original positions.

4IH03

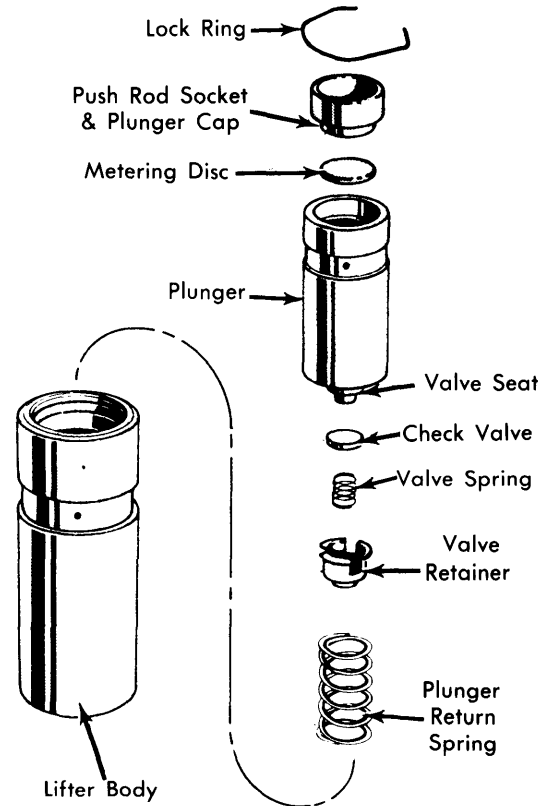

HYDRAULIC VALVE LIFTER ASSEMBLY

### HYDRAULIC VALVE LIFTER ADJUSTMENT

Hydraulic valve lifters do not require periodic adjustment.

## 1973-74 400" 8 ENGINE (Cont.)

PISTONS, PINS, RINGS						
Engine	PISTONS	PINS		RINGS		
	① Clearance	Piston Fit	① Rod Fit	Rings	End Gap	Side Clearance
1973-74 400"	.0010-.0018"	.0003-.0005"	.0008-.0019"	1	.010-.020"	.0015-.003"
				2	.010-.020"	.0015-.0035"
				3	.0015-.0055"	.000-.007"

① — Press fit.

### OIL PAN

No information available from manufacturer at time of publication for removal of oil pan with engine still installed in vehicle.

### PISTON & ROD ASSEMBLY

**Removal** — With oil pan and cylinder heads removed, check top of cylinder bore for a ridge or carbon deposits. Remove ridge with a ridge reamer before removing piston and rod assemblies. Rotate crankshaft until journal of rod being removed is at bottom. Remove rod nuts and rod cap. Push piston and rod assembly up and out. Place rod cap on respective cap, noting matching identification numbers.

**Installation** — Stagger all ring gaps before installing piston and rod assemblies. Make sure cylinder bores are clean and lubricated with motor oil. Make sure bearing inserts are properly located in rod and rod cap and crankshaft journal is clean and lubricated. Oil piston rings and compress with a suitable ring compressor. Install piston in bore with notch on top of piston toward front of engine. Push piston into bore, carefully aligning bearing on crankshaft journal. Install rod caps, matching numbers stamped in rod and rod cap on same side and tighten nuts.

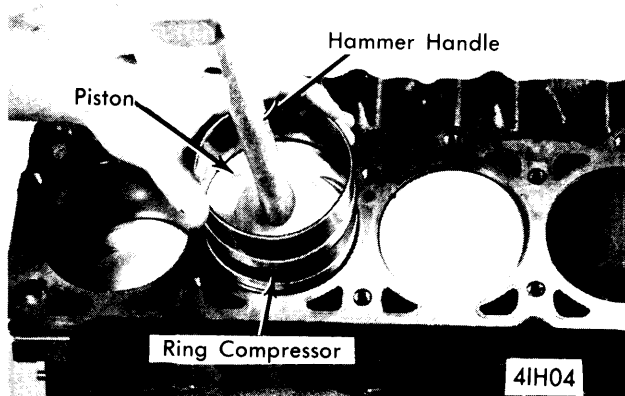

PISTON INSTALLATION

### FITTING PISTONS

1) Measure each cylinder bore with a micrometer or cylinder bore gauge to determine if bore is worn, tapered, or out-of-round. If cylinder bore is not out-of-round more than .003", tapered more than .005" or if piston-to-bore clearance is not excessive, cylinder will not need servicing, other than honing or de-glazing. Check ring end gap in cylinder bore with a feeler gauge.

2) To check piston-to-bore clearance, check pistons for scuffed or scored skirts and replace as necessary. Measure piston diameter at right angles to piston pin holes. Difference of cylinder bore and piston diameter is clearance. If clearance exceeds specifications, cylinder must be rebored and oversize pistons installed. Pistons and rings are available .010" oversize.

### PISTON PINS

**Removal** — With piston and rod assembly removed, press out piston pin using a suitable piston pin removal and installation tool (Tool Set No. SE-2438-1 and 2) and an arbor press. Place piston and rod assembly in tool support mounted in arbor press. Press out piston pin with tool set driver and separate piston from connecting rod. Mark or identify piston, pin and connecting rod to ensure identification of original assembly.

**Installation** — Check fit of pin in piston. If clearance is excessive, pin hole in piston can be reamed for oversize piston pins. Connecting rod must be reamed to obtain correct press fit of piston pin in connecting rod. Piston pins are available .003" and .005" oversize. Lubricate piston pin, pin holes in piston and connecting rod. Position piston on rod for even numbered bank cylinders with notch on top of piston toward numbered side of rod. Position piston on rod for odd numbered bank cylinders with notch on top of piston away from numbered side of rod. Press in piston pin using same tools as previously outlined.

# IHC V8 Engines

## 1973-74 400" 8 ENGINE (Cont.)

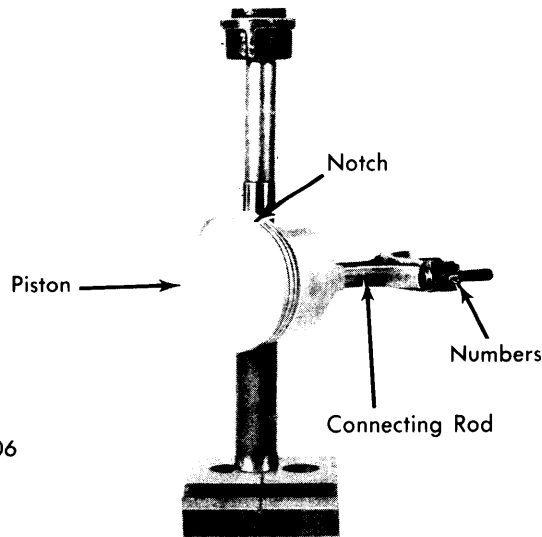

4IH06

PISTON &amp; ROD POSITION (EVEN BANK)

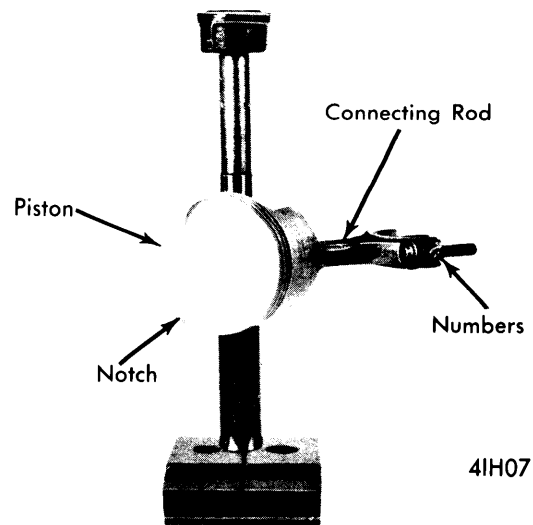

4IH07

PISTON &amp; ROD POSITION (ODD BANK)

### CRANKSHAFT MAIN & CONNECTING ROD BEARINGS

Engine	MAIN BEARINGS				CONNECTING ROD BEARINGS		
	Journal Diam.	Clearance	Thrust Bearing	Crankshaft Endplay	Journal Diam.	Clearance	Sideplay
1973-74 400"	① 2.7474-2.7489" ② 2.7464-2.7479"	① .001-.002" ② .002-.003"	No. 3	.003-.008"	2.2464-2.2485"	.001-.002"	.006-.013"

① — Journal Nos. 1, 2, 3 &amp; 4.

② — Journal No. 5.

#### MAIN & CONNECTING ROD BEARINGS

**Inspection** — Main and connecting rod bearing clearance is checked with the Plastigage method. If clearance exceeds specifications, crankshaft must be removed and ground for undersize bearings. Both main and connecting rod bearings are available .010" undersize. If journals are scored or out-of-round, crankshaft must be removed and ground for undersize bearings.

#### THRUST BEARING ALIGNMENT

Using a dial indicator, check crankshaft end play. If end play exceeds specifications, thrust bearing must be replaced.

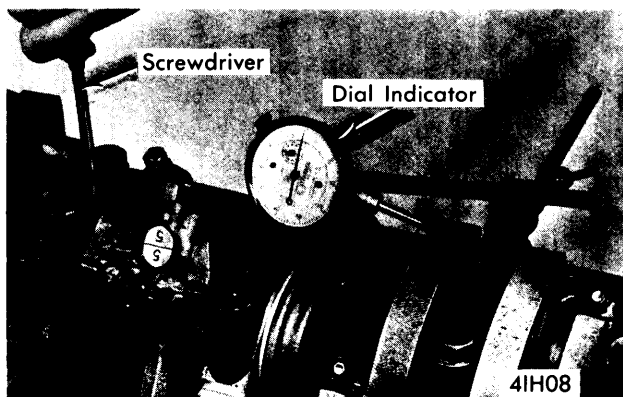

CHECKING CRANKSHAFT END PLAY

#### REAR MAIN BEARING OIL SEAL

**Removal** — Remove oil pan, gaskets, and front and rear seals. Remove rear main bearing cap and discard lower seal. Slightly loosen all remaining main bearing cap screws. Drive upper seal half out with a brass drift punch until enough is protruding to pull out with a pair of pliers.

**Installation** — Clean seal surface on crankshaft and lubricate with motor oil. Coat seal groove in cylinder block with soap and coat lip of seal with motor oil. Install upper seal half in cylinder block. Coat both sides of lower seal end tabs with sealer. Coat sealing lip of lower seal with oil and install seal in main bearing cap. Place sealer on chamfered edges of rear main bearing cap. Install rear main bearing cap and bearing. Tighten all main bearing caps.

#### VIBRATION DAMPER

**Removal** — Loosen all drive belts and slide off of crankshaft pulley. Remove drive pulley bolts and remove pulley. Remove damper retaining bolt and pull off damper with a suitable puller.

**Installation** — Apply motor oil to seal contact surface on damper. Align damper key slot with key in crankshaft. Tap damper into place with a hammer. Tighten damper bolt, install pulley and tighten bolts. Install belts and adjust belt tension.

#### FRONT ENGINE COVER

**Removal** — 1) Drain cooling system and remove radiator and by-pass hoses. Remove all drive belts and fan and hub assembly. If equipped with air conditioning, remove com-

## 1973-74 400" 8 ENGINE (Cont.)

pressor and bracket assembly and lay off to side. Remove air conditioning idler pulley if equipped. Remove alternator and bracket.

2) Disconnect heater hose from water pump. Remove power steering pump and bracket (if equipped) but do not disconnect hoses. Remove distributor cap and note position of rotor. Remove distributor and fuel pump. Remove vibration damper as previously outlined. Remove two front oil pan bolts and front engine cover bolts. Remove front engine cover and gasket.

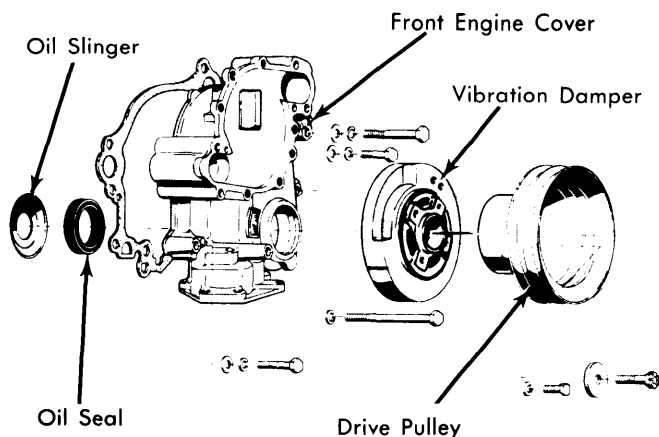

41H09

### FRONT ENGINE COVER

**Installation** — Remove lower locating dowel pin from cylinder block. Use a razor blade to cut excess old oil pan gasket flush against cylinder block. Cut a corresponding amount off a new oil pan gasket. Apply sealer to both sides of new gasket and install new oil pan front seal. Apply sealer to both pieces of new oil pan gasket and position on oil pan. Install front engine cover in position. Install two oil pan bolts and tighten until cover aligns with upper dowel. Install lower dowel in position through hole in front cover. Install remaining cover bolts and reverse removal procedure to complete installation.

### FRONT COVER OIL SEAL

**NOTE** — Front engine cover must be removed to remove front cover oil seal.

**Removal & Installation** — With front cover removed pry out old seal and clean seal bore in cover. Apply sealer to outside diameter of new seal. Drive new seal into place from inside cover with a suitable driver (J-22533). Apply oil to contact lip of seal and reinstall front cover.

CAMSHAFT			
Engine	Journal Diam.	Clearance	Lobe Lift
1973-74 400" No. 1	2.1195-2.1205"	.001-.003"	.....
	No. 2 2.0985-2.0905"		
	No. 3 2.0595-2.0605"		
	No. 4 2.0295-2.0305"		
	No. 5 1.9995-2.0005"		

### TIMING CHAIN & SPROCKETS

**Removal** — Remove front engine cover as previously outlined. Remove oil slinger and camshaft sprocket retaining bolt and washer. Remove distributor drive gear and fuel pump eccentric. Rotate crankshaft until timing marks on camshaft and crankshaft sprockets are aligned (see illustration). Remove crankshaft sprocket, camshaft sprocket and timing chain as an assembly.

**Installation** — Position timing chain on sprockets with sprocket marks aligned (see illustration). Install assembly on crankshaft and camshaft. To complete installation, reverse removal procedure. To check correct timing chain and sprocket installation, rotate crankshaft until timing mark on camshaft sprocket is at 3 o'clock position. Starting with timing chain pin directly adjacent to camshaft sprocket timing mark, count number of pins down to crankshaft timing mark. If chain is correctly installed there should be 20 pins between marks. Crankshaft timing mark should be between pin numbers 20 and 21 (see illustration).

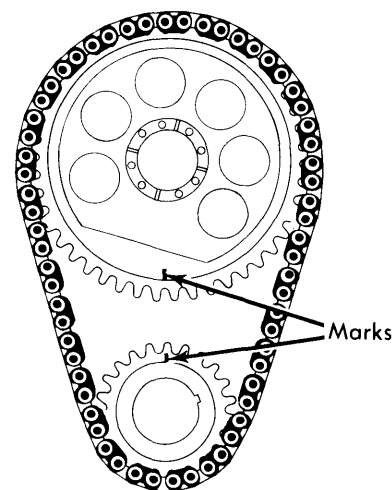

41H010

### VALVE TIMING MARKS

### CAMSHAFT

**Removal** — Drain cooling system and remove radiator. Remove valve covers, rocker arms and push rods as previously outlined. Remove intake manifold and hydraulic valve lifters. Remove front engine cover and timing chain and sprockets as previously outlined. Pull camshaft out carefully toward front to remove. **NOTE** — Grill may have to be removed to remove camshaft.

**Installation** — Check camshaft journals and lobes for wear or scoring. Replace camshaft as necessary. Lubricate camshaft completely before installation. Reverse removal procedure to install camshaft.

### CAMSHAFT BEARINGS

Camshaft bearings are stepbored in cylinder block, being larger at front bearing than at rear, permitting easy removal and installation of camshaft. When installing new bearings,

## 1973-74 400" 8 ENGINE (Cont.)

make sure that oil holes in bearings are aligned with oil holes in cylinder block. Coat edge of rear cam plug with sealer and drive into position until plug is flush with cylinder block.

### CAMSHAFT END THRUST

Camshaft end play is controlled by load on camshaft supplied by oil pump and distributor drive gear. The cut of gear holds camshaft to zero end play while engine is running.

### CAM LOBE LIFT

Remove individual rocker arm for camshaft lobe being checked. Mount a dial indicator with stem against push rod. Rotate engine until lifter is at base of camshaft lobe and set dial indicator to zero. Rotate engine again until maximum lift on push rod is obtained and take reading on dial indicator. If reading is .006" less than specifications, camshaft must be replaced.

## ENGINE OILING

**Crankcase Capacity** – All engines 5 quarts, add 1 quart with filter change.

**Oil Filter** – Oil filter should be changed every oil change or more often under dusty or severe conditions. Filter is full-flow type.

### Normal Oil Pressure

Application	PSI
Minimum @ Idle Speed.....	13
Minimum @ 1600 RPM (Or Higher).....	37
Maximum @ 1600 RPM (Or Higher).....	75

**Pressure Regulator Valve** – Located in oil pump.

### ENGINE OILING SYSTEM

Oil pump, driven by distributor shaft, provides full pressure lubrication to all camshaft, crankshaft and connecting rod bearings. Full pressure lubrication is also provided to valve lifters, push rods and rocker arms. Cylinder walls and piston pins are lubricated by splash oil from connecting rod journals.

### OIL PUMP

**Disassembly** – Oil pump body is integral with front engine cover. Cover must be removed to service or inspect oil pump components. Remove cover retaining screws and remove cover and oil filter as an assembly. Remove drive gear and idler gear from pump body. Remove pressure regulator valve plug, spring and valve from pump cover.

**Inspection** – Thoroughly clean all components in a suitable cleaning solution. Inspect all components for wear or damage. Place gears in pump body and position a straightedge across gears. Check gear end clearance with a feeler gauge. If clearance is not to specifications, replace gears and front engine cover. Check gear to pump body side clearance with a feeler gauge. If gear to body clearance exceeds specifications, replace drive gear and idler gear. Check pressure regulator spring free length. Apply specified amount of pressure to spring and check length. If less than specifications, replace spring. Check valve for wear or scoring and replace as necessary.

**Reassembly** – Lubricate all components with motor oil. Reverse disassembly procedure to assemble oil pump.

### Oil Pump Specifications

Application	Specification
Gear End Clearance.....	.002-.006"
Gear Side Clearance.....	.0005-.0025"
Pressure Regulator Spring .....	1.88" @ 17 lbs.

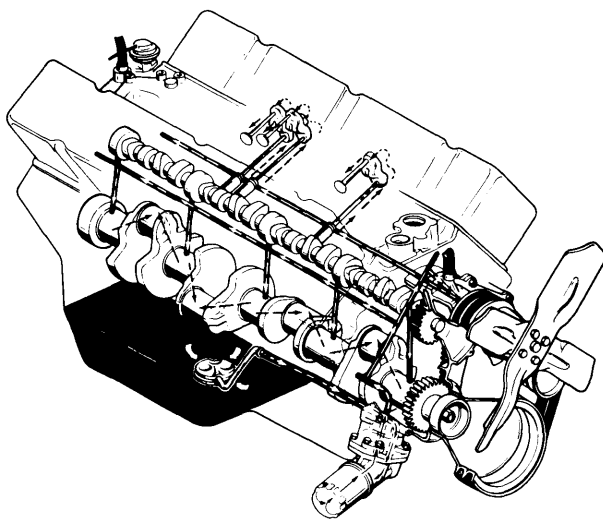

4IH011

ENGINE OIL SYSTEM

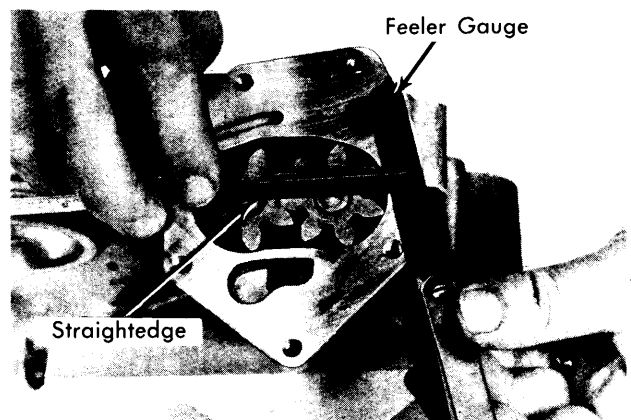

4IH012

CHECKING OIL PUMP GEARS END CLEARANCE

## 1973-74 400" 8 ENGINE (Cont.)

### ENGINE OILING (Cont.)

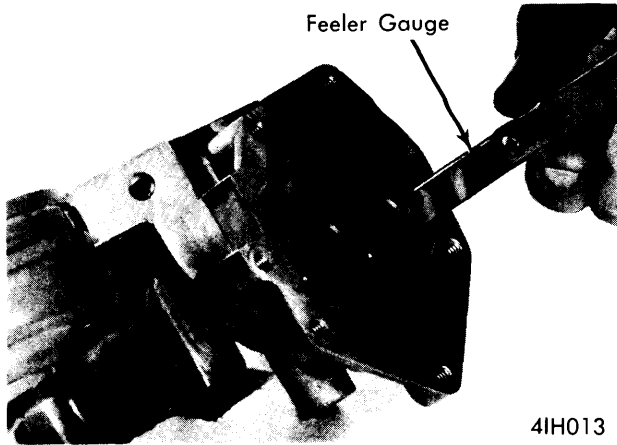

CHECKING OIL PUMP GEAR SIDE CLEARANCE

### TIGHTENING SPECIFICATIONS

Application	Ft. Lbs.
Connecting Rod Nuts.....	38
Cylinder Head Bolts.....	110
Main Bearing Cap Bolts.....	100
Intake Manifold Bolts .....	43
Front Engine Cover Bolts.....	25
Flywheel Or Drive Plate Bolts .....	105
Rocker Arm Studs.....	62
Camshaft Sprocket Bolt.....	30
Vibration Damper Bolt .....	55