

General Motors 4 Engines

1965-74 194", 230", 250", 292" 6 CYL. ENGINES

GENERAL SPECIFICATIONS							
Year	Displ. Cu. Ins.	Carburetor	HP at RPM	Torque (Ft. Lbs. at RPM)	Compr. Ratio	Bore	Stroke
1965	194"	1-Bbl.	120@4400	177@2400	8.5:1	3.5625"	3.250"
	230"	1-Bbl.	140@4400	220@1600	8.5:1	3.875"	3.250"
	230"Ⓢ	1-Bbl.	125@3400	210@1600	8.5:1	3.875"	3.250"
	292"	1-Bbl.	165@3800	280@1600	8.0:1	3.875"	4.120"
1966	194"	1-Bbl.	120@4400	177@2400	8.5:1	3.5625"	3.250"
	230"	1-Bbl.	140@4400	220@1600	8.5:1	3.875"	3.250"
	250"	1-Bbl.	150@4200	210@1600	8.5:1	3.875"	3.530"
	292"	1-Bbl.	170@4000	280@1600	8.0:1	3.875"	4.120"
1967-69	230"	1-Bbl.	140@4400	220@1600	8.5:1	3.875"	3.250"
	250"	1-Bbl.	155@4200	235@1600	8.5:1	3.275"	3.530"
	292"	1-Bbl.	170@4000	275@1600	8.0:1	3.875"	4.120"
1970	250"	1-Bbl.	155@4200	235@1600	8.5:1	3.875"	3.530"
	292"	1-Bbl.	170@4000	275@1600	8.0:1	3.875"	4.120"
1971	250"	1-Bbl.	145@4200	230@1600	8.5:1	3.875"	3.530"
	292"	1-Bbl.	165@4000	270@1600	8.0:1	3.875"	4.120"
1972	250"	1-Bbl.	110@3800	125@3600	8.5:1	3.875"	3.530"
	292"	1-Bbl.	185@1600	225@2400	8.0:1	3.875"	4.120"
1973	250"	1-Bbl.	100@3600	120@3600	8.25:1	3.875"	3.530"
	292"	1-Bbl.	175@2000	215@2000	8.0:1	3.875"	4.120"
1974	250"	1-Bbl.	100@3600	120@3600	8.25:1	3.875"	3.530"
	292"	1-Bbl.	175@1800	215@2000	8.0:1	3.875"	4.120"

Ⓢ - Economy option.

► **NET HORSEPOWER & TORQUE NOTE** - Horsepower and Torque figures given for 1972 and later are NET. NET Horsepower and Torque represent power at the flywheel when the engine is installed in the vehicle, with wide open throttle and all systems operating such as; air cleaner, exhaust system, water pump, generator, oil pump and air conditioning.

ENGINE IDENTIFICATION

Engine code letters are suffix of Engine Identifications Number. Number is stamped on a pad, located at right side of cylinder block next to distributor.

1965 Chevrolet

Application	Code
194" 6 Cyl. Man. Trans.	SG
194" 6 Cyl. Auto. Trans.	SI
230" 6 Cyl. Man. Trans.	TA, TG, TH, TJ
230" 6 Cyl. Auto. Trans.	TE, TI, TK
292" 6 Cyl. Man. Trans.	UH, UV
292" 6 Cyl. Auto. Trans.	UT, UU

1965 GMC

Application	Code
194" Man. Trans.	SCT, SJT
194" Auto. Trans.	SIT
230" Man. Trans.	TA, TG, TJ, TH, SKT, SMT
230" Auto. Trans.	TE, TK, TI, SLT, SNT
292" Man. Trans.	UH, UV, TO, UW
292" Auto. Trans.	UT, UU

1966 Chevrolet

Application	Code
194" Man. Trans.	SG, SC
194" Man. Trans. W/A.I.R.	SC, SD
194" Auto. Trans.	SI, SF
194" Auto. Trans. W/A.I.R.	SD, SP
230" Man. Trans.	SK, TH

1966 CHEVROLET (Cont.)

Application	Code
230" Man. Trans. W/A.I.R.	SR, ST
230" Auto. Trans.	TI
230" Auto. Trans. W/A.I.R.	SS, SU
250" Man. Trans.	TA, TJ, TF
250" Man. Trans. W/A.I.R.	SV, SX
250" Auto. Trans.	SL, TE, TK
250" Auto. Trans. W/A.I.R.	SW
292" Man. Trans.	UH, UV
292" Man. Trans. W/A.I.R.	VQ
292" Auto. Trans.	UT, UU
292" Auto. Trans. W/A.I.R.	VR

1966 GMC

Application	Code
194" Man. Trans.	SHT, SGT, SE
194" Man. Trans. W/A.I.R.	SCT, SO
194" Auto. Trans.	SJT, SIT, SF
194" Auto. Trans. W/A.I.R.	SDT, SP
230" Man. Trans.	SKT
230" Man. Trans. W/A.I.R.	SRT, ST
230" Auto. Trans.	SLT
230" Auto. Trans. W/A.I.R.	SST, SU
250" Man. Trans.	TA, TF, TJ
250" Man. Trans. W/A.I.R.	SU, SX
250" Auto. Trans.	SL, TE, TK
250" Auto. Trans. W/A.I.R.	SW
292" Man. Trans.	UH, UV
292" Man. Trans. W/A.I.R.	VQ
292" Auto. Trans.	UT, UU
292" Auto. Trans. W/A.I.R.	VR

General Motors 6 Engines

7-83

1965-74 194", 230", 250", 292" 6 CYL. ENGINES (Cont.)

1967 Chevrolet	
Application	Code
230" Man. Trans.	SK, TH
230" Man. Trans. W/A.I.R.	SR, ST
230" Auto. Trans.	SL, TI
230" Auto. Trans. W/A.I.R.	SS, SU
250" Man. Trans.	SE, TA, TJ, TF, UC
250" Man. Trans. W/A.I.R.	SF, SU, SX, UO
250" Auto. Trans.	SO, TE, UC, UG
250" Auto. Trans. W/A.I.R.	SP, SW, UN
292" Man. Trans.	UH, UV
292" Man. Trans. W/A.I.R.	VQ
292" Auto. Trans.	UQ, UT, UU
292" Auto. Trans. W/A.I.R.	UR

1969 GMC	
Application	Code
230" Man. Trans.	OA, OM
230" Man. Trans. W/A.I.R.	OK
230" Auto. Trans.	OB, ON
230" Auto. Trans. W/A.I.R.	OL
250" Man. Trans.	PA, PL, PK
250" Man. Trans. W/A.I.R.	PC, PP
250" Auto. Trans.	PX, PM
250" Auto. Trans. W/A.I.R.	PE, PW
292" Man. Trans.	RE
292" Man. Trans. W/A.I.R.	RS, RG
292" Auto. Trans.	RA, RB
292" Auto. Trans. W/A.I.R.	RR, RD, RQ

1967 GMC	
Application	Code
230" Man. Trans.	SK, Th
230" Man. Trans. W/A.I.R.	SR, ST
230" Auto. Trans.	SL, TI
230" Auto. Trans. W/A.I.R.	SS, SU
250" Man. Trans.	SE, TA, TJ, TF, UC
250" Man. Trans. W/A.I.R.	SF, SU, SX, UO
250" Auto. Trans.	SO, TE, TK, UG
250" Auto. Trans. W/A.I.R.	SP, SW, UN
292" Man. Trans.	UH, UV
292" Man. Trans. W/A.I.R.	VQ
292" Auto. Trans.	UQ, UT, UU
292" Auto. Trans. W/A.I.R.	TS, UR

1970 Chevrolet	
Application	Code
250" Man. Trans.	TAA, TAB, TCN, TCK
250" Man. Trans. L.P. Gas	TCE, TNR, TCC
250" Auto. Trans.	TAC, TAD, TNX, TCA, TCB, TNW
250" Auto. Trans. L.P. Gas	TCF, TCG, TCI, TCM
292" Man. Trans.	TCZ, TNA
292" Man. Trans. L.P. Gas	TND
292" Auto. Trans.	TAG, TCU, TAF
292" Auto. Trans. L.P. Gas	TNC, TNE

1968 Chevrolet	
Application	Code
230" Man. Trans.	PK, PR, PA
230" Auto. Trans.	PL, PU, PO
250" Man. Trans.	TA, PV, PH, PI, PE
250" Auto. Trans.	TE, TT, PW, PJ, TI
292" Man. Trans.	UH, U3, UM
292" Auto. Trans.	UT, UP, UO, UQ

1970 GMC	
Application	Code
250" Man. Trans.	TCN, TCC, TAB, TCK
250" Auto. Trans.	TNW, TNX, TCB, TCA, TAC, TAD, TAC
292" Man. Trans.	TNA
292" Auto. Trans.	TCU, TAF, TAG

1968 GMC	
Application	Code
230" Man. Trans.	PK, PA, PE, TF
230" Man. Trans. W/A.I.R.	PK
230" Auto. Trans.	PU, PO, TI, PW
230" Auto. Trans. W/A.I.R.	PL
250" Man. Trans.	PI, PV, TF
250" Man. Trans. W/A.I.R.	PH, TA, PF
250" Auto. Trans.	TB, PW
250" Auto. Trans. W/A.I.R.	PJ, TE
292" Man. Trans.	UM
292" Man. Trans. W/A.I.R.	UH
292" Auto. Trans.	UO, UQ
292" Auto. Trans. W/A.I.R.	UT, UP

1971 Chevrolet	
Application	Code
250" Man. Trans.	TPT, TPW, TPR, TKH, TPD, TPL, TKD, TRB, TPJ, TBB
250" Man. Trans. LPG	TPX, TKJ
250" Auto. Trans.	TPY, TPS, TTK, TPH, TKG, TPK
292" Man. Trans.	TKL
292" Man. Trans. LPG	TKP
292" Auto. Trans.	TKR, TKS

1969 Chevrolet	
Application	Code
230" Man. Trans.	OA
230" Auto. Trans.	QN, QL, OB, OD
250" Man. Trans.	PB, PC, PE, PK, PL, PP, PQ, OS, OT
250" Auto. Trans.	PD, PM, PO, PW, PX, OO, OV, OX, OZ
292" Man. Trans.	RE, RG, RS
292" Auto. Trans.	RR, RA, RB, RC, RD, RQ

1971 GMC	
Application	Code
250" Man. Trans.	TCG, TCL, TLG, TLH, TCD
250" Auto. Trans.	TCK, TCT, TCS, TLC
250" LPG	TCP
292" Man. Trans.	TGA
292" Auto. Trans.	TGB, TGD
292" LPG	TGC, TGG

1972 Chevrolet & GMC	
Application	Code
250" Man. Trans.	TPT, TPW, TPR, TKH, TPD, TPL, TKD, TRB, TPJ, TBB
250" Man. Trans. LPG	TPX, TKJ
250" Auto. Trans.	TPY, TPS, TTK, TPH, TKG, TPK
292" Man. Trans.	TKL
292" Man. Trans. LPG	TKP
292" Auto. Trans.	TKR, TKS

General Motors 6 Engines

1965-74 194", 230", 250", 292" 6 CYL. ENGINES (Cont.)

1973 Chevrolet & GMC

Application	Code
250" Man. Trans.	TAJ, TAT, TAX, TAY, TAM, TBA, TBH, TBJ, TAB, TBM TAC, TAD, TAH, TAK, TAL
250" Auto. Trans.	TAA, TBL, TAJ, TAS, TAW, TAR, TAZ, TBL, TBC
292" Man. Trans.	TRC, THC, THD, THL
292" Auto. Trans.	THA, THB, THH, THJ

1974 Chevrolet & GMC

Application	Code
250" Man. Trans.	TAB, TAC, TAD, TAH, TAK, TAL, THM, TAT, TAU, TBA, TBX, TBK, TBH
250" Auto. Trans.	TAJ, TBL, TAR, TAS, TAW TAA, TAZ, TBC, TBD
250" LPG	TBM
292" Man. Trans.	THU, THW
292" Auto. Trans.	THS, THT
292" LPG	THD

Installation — Ensure gasket surfaces are clean. Place manifold in position, tighten center clamp bolts and then tighten end bolts. Reverse removal procedure to complete installation.

CYLINDER HEAD

Removal — Remove intake manifold as previously outlined. Disconnect temperature wire from clip on rocker arm cover. Remove air injection hose at check valve of AIR pipe (if equipped) and remove rocker arm cover. Back off rocker arm adjustment nuts, pivot rocker arms to side and remove push rods. Drain cooling system and remove fuel and vacuum line from retaining clip at water outlet. Disconnect radiator hose at water outlet and battery ground strap. Remove coil and disconnect spark plug wires. Remove cylinder head bolts and remove cylinder head.

Installation — Ensure that gasket surface on cylinder head and block are clean and all head bolt threads and threads in cylinder block are clean. To install cylinder head, reverse removal procedure. Do not apply sealer to head gasket if asbestos type gasket is being used. Coat threads of cylinder head bolts with sealer. Tighten cylinder head bolts in sequence shown in illustration. Install push rods and adjust hydraulic valve lifters. See *Hydraulic Valve Lifter Adjustment*.

ENGINE REMOVAL

See *Engine Removal at end of ENGINE Section*.

INTAKE MANIFOLD

Removal — Remove air cleaner, disconnect both throttle rods at bellcrank and remove throttle return spring. Disconnect fuel line, vacuum lines and choke cable (if equipped) at carburetor. Disconnect crankcase vent hose at rocker arm cover. Disconnect exhaust pipe at flange and remove manifold attaching bolts and clamps. Remove intake and exhaust manifold as an assembly.

4GMO1

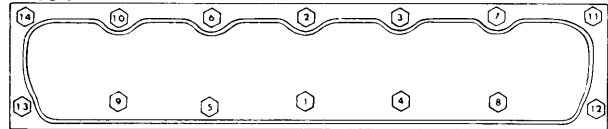

CYLINDER HEAD BOLT TIGHTENING SEQUENCE

VALVES							
Engine & Valve	Head Diam.	Face Angle	Seat Angle	Seat Width	Stem Diameter	Stem Clearance	Valve Lift
1965-74							
194"							
Int.	1.720"	45°	46°	.031-.064"	.3404-.3417"	.0010-.0027"
Exh.	1.500"	45°	46°	.063-.094"	.3403-.3417"	.0015-.0033"
230"							
Int.	1.720"	45°	46°	.031-.063"	.3410-.3417"	.0010-.0027"
Exh.	1.500"	45°	46°	.063-.094"	.3410-.3417"	.0015-.0032"
250"							
Int.	1.720"	45°	46°	.031-.063"	.3410-.3417"	.0010-.0027"
Exh.	1.500"	45°	46°	.063-.094"	.3410-.3417"	.0015-.0032"
292"							
Int.	1.720"	45°	46°	.031-.063"	.3410-.3417"	.0010-.0027"
Exh.	1.500"	ⓐ45°	46°	.063-.094"	.3410-.3417"	.0010-.0027"

- ⓐ — Stem diameter for 1965-67 230", 250" and 292" engines is .3404-.3417".
- ⓑ — Exhaust valve stem clearance for 1965-67 230" and 250" engines is .0015-.0027".
- ⓒ — Exhaust valve face angle for 1968-69 292" engines is 46°.

1965-74 194", 230", 250", 292" 6 CYL. ENGINES (Cont.)

VALVE ARRANGEMENT

E-I-I-E-E-I-I-E-E-I-I-E (Front to rear.)

VALVE GUIDES

Valve guides are integral with cylinder head. If guide is worn, it must be reamed for valve with oversize stem. Valves are available with stems .003, .015 and .030" oversize. Use suitable reamers to ream valve guide bore to specified clearance for oversize stems.

VALVE STEM OIL SEALS

A small "O" ring type seal is installed in second groove in valve stem before valve keepers are installed. See *Valve Springs*.

Installation — To install valve spring, place shims, spring and damper, shield and retainer on valve stem. Compress spring with a suitable spring compressor. Install new "O" ring type seal in second groove on valve stem. Install valve keepers in upper groove on valve stem and release spring compressor.

VALVE SPRING INSTALLED HEIGHT

Using a narrow thin scale, check valve spring installed height by measuring from top of shim or spring seat in head to top of valve spring or shield. If height exceeds specified height, install a 1/16" thick shim under spring. Installed height should never be less than specified height.

ROCKER ARM STUDS

Rocker arm studs that are loose in head or have damaged threads can be replaced with oversize studs. Studs are available .003" and .013" oversize.

Removal — Remove stud using a suitable stud extractor (J-5802-1). Install extractor over stud and tighten nut until stud is pulled from cylinder head.

Installation — Ream hole for oversize studs with a suitable reamer (J-5715 for .003" oversize and J-6036 for .013" oversize). Coat press fit area of stud with hypoid axle grease. Drive rocker stud into place with a suitable driver (J-6880) and a hammer. When driver bottoms on head, stud is at correct height.

VALVE SPRINGS			
Engine	Free Length	PRESSURE (LBS.)	
		Valve Closed	Valve Open
1965 194" & 230" 292"	2.03 2.08"	84-92@1.66" 78-80@1.66"	166-176@1.33" 170-180@1.26"
1966 194" 230" 250" 292"	1.92" 1.90" 2.08" 2.08"	56-64@1.66" 56-64@1.66" 56-64@1.66" 85-93@1.69"	170-184@1.33" 170-184@1.33" 180-192@1.27" 174-184@1.30"
1967 230" 250" 292"	1.90" 2.08" 2.08"	56-64@1.66" 56-64@1.66" 85-93@1.69"	170-184@1.33" 180-192@1.27" 174-184@1.30"
1968-74 230" 250" 292"	1.90" 1.90" 1.90"	56-64@1.66" 56-64@1.66" 85-93@1.69"	170-184@1.33" 180-192@1.29" 174-184@1.30"

VALVE SPRINGS

Removal — With cylinder head removed, compress valve spring with a suitable spring compressor. Remove valve keepers and release spring compressor. Remove spring retainer, shield, spring and damper, and any shims under spring.

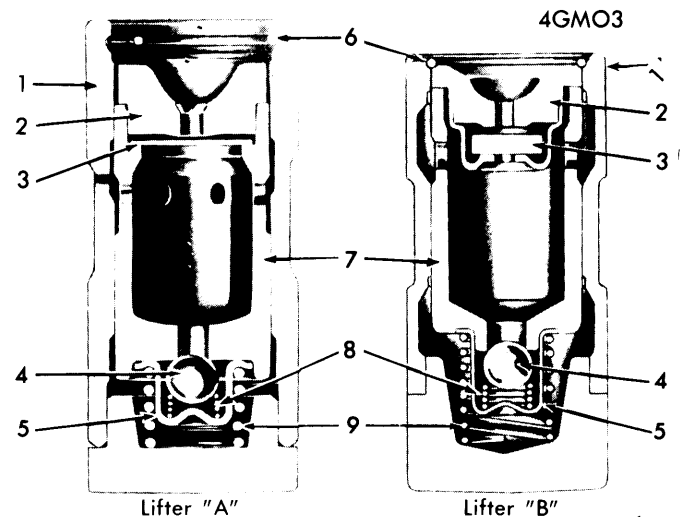
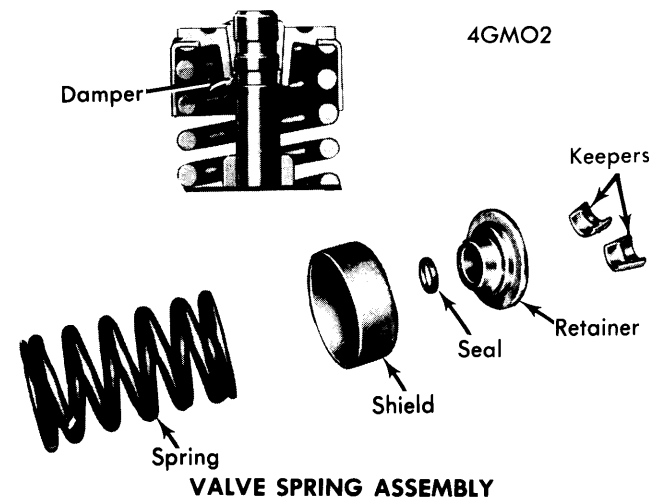

- | | |
|---------------------------------|----------------------------|
| 1 — Lifter Body | 5 — Check Ball Retainer |
| 2 — Push Rod Seat | 6 — Push Rod Seat Retainer |
| 3 — Metering Valve (Lifter "A") | 7 — Plunger |
| 3 — Inertia Valve (Lifter "B") | 8 — Check Ball Spring |
| 4 — Check Ball | 9 — Plunger Spring |

HYDRAULIC VALVE LIFTER ASSEMBLIES

General Motors 6 Engines

1965-74 194", 230", 250", 292" 6 CYL. ENGINES (Cont.)

HYDRAULIC VALVE LIFTER ASSEMBLY

NOTE — Two types of valve lifters are used. Lifters operate in same manner and are serviced basically the same. Lifter "A" is used from 1965-74 and lifter "B" was used from 1967-72.

Disassembly — Depress plunger in lifter with a push rod and pry out retainer with a small blade screwdriver. Remove push rod seat and metering valve (lifter "A") or inertia valve (lifter "B"). Remove plunger, ball check valve and assembly, and plunger spring. Remove ball check valve and spring by prying ball retainer loose with a small blade screwdriver.

Assembly — 1) Thoroughly clean and inspect all components. If any components are worn or damaged, complete lifter must be replaced. **NOTE** — Inertia valve (lifter "B") should not be removed from push rod seat. If valve moves when shaken, valve is functional.

2) Position check ball on small hole in bottom of plunger. Insert check ball spring on seat in ball retainer and position

retainer on ball so that spring seats on ball. Using a screwdriver, press plunger into position.

3) Slide lifter body over spring and plunger, lining up oil feed holes. Fill assembly with SAE 10 oil and depress plunger to stop. With plunger depressed, insert a $\frac{1}{16}$ " drift punch into feed holes. Release plunger and refill with SAE 10 oil.

4) Install metering valve (lifter "A") or inertia valve (lifter "B"), push rod seat and retainer. Depress push rod seat and remove drift punch.

HYDRAULIC VALVE LIFTER ADJUSTMENT

Rotate engine until rotor is at number 1 cylinder position and points are just opening. With engine at this position, adjust intake valves 1, 2 and 4 and exhaust valves 1, 3 and 5. Back off rocker arm nuts until lash is felt, then tighten nut until all lash is removed and tighten 1 full additional turn. Now rotate engine until rotor is at number 6 position and points are just opening. Following same procedure and adjust intake valves 3, 5 and 6 and exhaust valves 2, 4 and 6.

PISTONS, PINS, RINGS

Engine	PISTONS		PINS		RINGS		
	①Clearance	Piston Fit	Pin Fit	Rod Fit	Rings	End Gap	Side Clearance
1965-67 194" & 230"	.0005-.0011"	.00015-.00025"	.0008-.0016"		1	.010-.020"	.0012-.0027"
					2	.010-.020"	.0012-.0032"
					3	.015-.055"	.000-.005"
250"	.0005-.0011"	.00015-.00025"	.0008-.0016"		1	.010-.020"	.0020-.0035"
					2	.010-.020"	.0020-.0040"
					3	.015-.055"	.000-.005"
292"	.0026-.0032"	.00025-.00035"	.0008-.0016"		1	.010-.020"	.0020-.0040"
					2	.010-.020"	.0020-.0040"
					3	.015-.055"	.0005-.0055"
1968 230" & 250"	.0005-.0011"	.00015-.00025"	.0008-.0016"		1	.010-.020"	.0012-.0027"
					2	.010-.020"	.0012-.0032"
					3	.015-.055"	.000-.005"
292"	.0026-.0032"	.00025-.00035"	.0008-.0016"		1	.010-.020"	.0020-.0040"
					2	.010-.020"	.0020-.0040"
					3	.015-.055"	.0005-.0055"
1969 230" & 250"	.0005-.0014"	.00015-.00025"	.0008-.0016"		1	.010-.020"	.0012-.0027"
					2	.010-.020"	.0012-.0032"
					3	.015-.055"	.000-.005"
292"	.0026-.0032"	.00025-.00035"	.0008-.0016"		1	.010-.020"	.0020-.0040"
					2	.010-.020"	.0020-.0040"
					3	.015-.055"	.0005-.0055"
1970 250"	.0005-.0015"	.00015-.00025"	.0008-.0016"		1	.010-.020"	.0012-.0027"
					2	.010-.020"	.0012-.0032"
					3	.015-.055"	.000-.005"
292"	.0025-.0031"	.00025-.00035"	.0008-.0016"		1	.010-.020"	.0020-.0040"
					2	.010-.020"	.0020-.0040"
					3	.015-.055"	.0005-.0055"

1965-74 194", 230", 250", 292" 6 CYL. ENGINES (Cont.)

PISTONS, PINS, RINGS						
Engine	PISTONS ① Clearance	PINS		RINGS		
		Piston Fit	Rod Fit	Rings	End Gap	Side Clearance
1971-72 250"	.0005-.0015"	.00015-.00025"	.0008-.0016"	1	.010-.020"	.0012-.0027"
				2	.010-.020"	.0012-.0032"
				3	.015-.055"	.000-.005"
292"	.0025-.0035"	.00015-.00025"	.0008-.0016"	1	.010-.020"	.0020-.0040"
				2	.010-.020"	.0020-.0040"
				3	.015-.055"	.0005-.0055"
1973-74 250"	.0005-.0015"	.00015-.00025"	.0008-.0016"	1	.010-.020"	.0012-.0027"
				2	.010-.020"	.0012-.0027"
				3	.015-.055"	.000-.005"
292"	.0026-.0036"	.00015-.00025"	.0008-.0016"	1	.010-.020"	.0020-.0040"
				2	.010-.020"	.0020-.0040"
				3	.015-.055"	.0005-.0055"

① — Interference fit.

OIL PAN

See *Oil Pan Removal at end of ENGINE Section.*

PISTON & ROD ASSEMBLY

Removal — With oil pan, oil pump and cylinder head removed, remove any ridge in top of cylinder bore with a suitable ridge reamer. Check connecting rod and cap for identification marks or numbers and identify if necessary. Remove connecting rod cap nuts and rod cap. Push piston and rod assembly up and out of cylinder block. It will be necessary to rotate crankshaft to various positions to facilitate removing piston and rod assemblies.

Installation — Before installing piston and rod assembly, place ring end gaps in positions shown in illustration. Ensure that cylinder bores are clean and oiled before installing piston and rod assemblies. Lubricate crankshaft journal and rod bearings. Compress piston rings with a suitable ring compressor. Position piston and rod assembly in bore with notch in top of piston facing toward front of engine. Push piston and rod assembly into position carefully aligning bearing on crankshaft. Install connecting rod cap noting identification marks and evenly tighten rod nuts.

FITTING PISTONS

1) With piston and rod assemblies removed, wipe cylinder bores clean and measure diameter 2 1/2" below top of cylinder with a micrometer. If cylinder is worn or tapered more than .005", cylinder must be bored for oversize pistons.

2) If bore is worn or tapered less than .005", cylinder can be cleaned and honed, and .001" oversize pistons installed. If cylinders are bored, various oversize pistons are available. See oversize piston table for oversize pistons available from manufacturer.

Oversize Pistons

Application	Size
194"020, .030 & .040"
230"020, .030 & .040"
250"	
1965-70020, .030 & .040"
1972-74030"
292"	
1965-67020, .030 & .040"
1968-71020 & .040"
1972-74030"

3) To check fit of rings in cylinder bore, insert ring in cylinder bore and push ring into bore 2" with head of piston and measure ring end gap with a feeler gauge. Before installing rings on pistons, ensure ring grooves are clean of carbon and

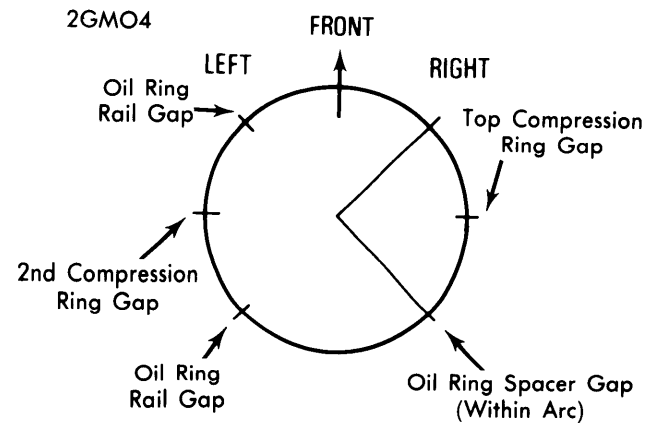

RING GAP LOCATIONS

General Motors 6 Engines

1965-74 194", 230", 250", 292" 6 CYL. ENGINES (Cont.)

inspect grooves for nicks or burrs. Install rings with gaps positioned as shown in illustrations.

PISTON PINS

Removal — With piston and rod assembly removed, press out piston pin using a suitable removing and installing tool set (J-6964 for 1965-66 engines and J-9510 for 1967-74 engines), and an arbor press. Separate piston from connecting rod.

Installation — Check clearance of piston pin in piston. If clearance exceeds .001" over specified clearance, piston and pin must be replaced. Position piston on rod so that bearing tangs face away from camshaft and notch on top of piston is toward front of engine. Lubricate piston pin and press in using same tools as outlined in removal procedure. Check piston for freedom of movement on piston pin.

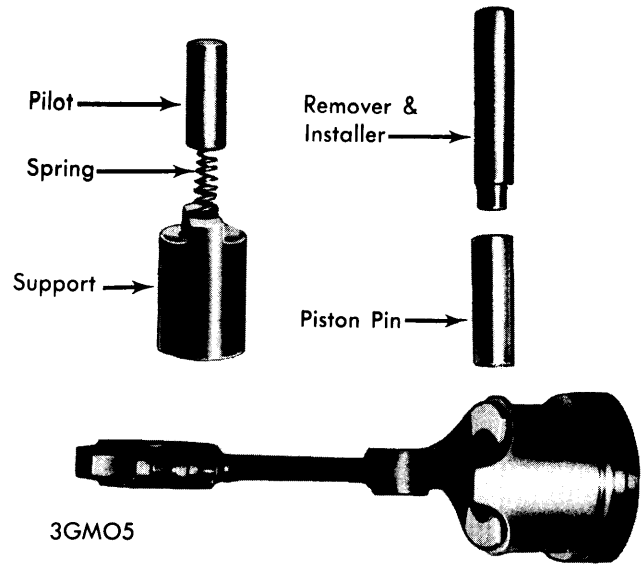

PISTON PIN REMOVAL & INSTALLATION

CRANKSHAFT MAIN & CONNECTING ROD BEARINGS							
Engine	MAIN BEARINGS				CONNECTING ROD BEARINGS		
	Journal Diam.	Clearance	Thrust Bearing	Crankshaft End Play	Journal Diam.	Clearance	Side Play
1965-66							
194"	2.2983-2.2993"	.0008-.0040"	No. 7	.002-.006"	1.999-2.000"	.0007-.0028"	.008-.014"
230" & 250"	2.2983-2.2993"	.0003-.0029"	No. 7	.002-.006"	1.999-2.000"	.0007-.0027"	.009-.014"
292"	2.2983-2.2993"	.0008-.0034"	No. 7	.002-.006"	2.099-2.100"	.0007-.0028"	.009-.014"
1967-72							
230" & 250"	2.2983-2.2993"	.0003-.0029"	No. 7	.002-.006"	1.999-2.000"	.0007-.0027"	.009-.014"
292"	2.2983-2.2993"	.0008-.0034"	No. 7	.002-.006"	2.099-2.100"	.0007-.0027"	.009-.014"
1973-74							
250"	2.2983-2.2993"	.0003-.0029"	No. 7	.002-.006"	1.999-2.000"	.0007-.0027"	.006-.017"
292"	2.2983-2.2993"	.0008-.0034"	No. 7	.002-.006"	2.099-2.100"	.0007-.0027"	.006-.017"

MAIN & CONNECTING ROD BEARINGS

NOTE — Following procedures are performed with oil pan and oil pump removed.

Connecting Rod Bearings — 1) Mark or identify rod cap to rod before removing rod cap nuts. With rod nuts removed, remove rod cap and bearing. Push up on piston and rod assembly and remove bearing from rod. Inspect bearings for wear or damage and replace as necessary.

2) Check crankshaft rod bearing journal for out-of-round or taper conditions. If crankshaft is out-of-round or tapers more than .001", crankshaft must be removed and ground for undersize bearings.

3) Check rod bearing clearance using the Plastigage method. If clearance exceeds specifications, a .001" or .002" undersize bearing may be installed to obtain correct clearance. If clearance is still excessive, crankshaft must be removed and ground for undersize bearings. Connecting rod bearings are available .010" and .020" undersize.

4) To install bearings, clean crankshaft journal and bearing surface in rod. Insert bearing halves in rod and cap. Lubricate journal and pull piston and rod assembly down, aligning bearing on journal. Install rod cap noting identification marks and evenly tighten rod nuts.

Main Bearings — 1) Main bearings are selective fit by manufacturer during production. A standard size bearing half may be used in combination with a .001" undersize bearing half to obtain correct clearance. This combination will decrease clearance .0005".

2) If correct clearance could not be obtained during production, a crankshaft with .009" undersize main bearing journals is fitted. A .009" and .010" bearing half combination may be used to obtain correct clearance.

3) If engine is fitted with a crankshaft with .009" undersize main bearing journals, it will be identified by a 9 stamped in left front oil pan rail. Crankshaft can also be identified by a .009" stamped in crankshaft counterweight forward of center main bearing.

1965-74 194", 230", 250", 292" 6 CYL. ENGINES (Cont.)

4) Main bearings may be removed and replaced with crankshaft still installed. Mark or identify main bearing caps to cylinder block before removing caps. With the exception of rear main bearing, main bearings are removed from cylinder block by inserting a bearing removal and installing tool in oil hole in crankshaft and rotating crankshaft clockwise. To remove rear main bearing, drive bearing partly out with a drift punch and hammer. Using a pair of pliers with taped jaws, grab bearing thrust surface and slinger on crankshaft and rotate crankshaft to remove bearing.

5) Crankshaft clearance, taper or out-of-round conditions can be checked using the Plastigage method. If clearance exceeds specifications, a .001" or .002" undersize bearing may be installed to obtain correct clearance. Both bearing halves must be replaced.

6) If correct clearance cannot be obtained or if journal is tapered or is out-of-round more than .001", crankshaft must be removed and ground for undersize bearings. Bearings are available .010", .020" and .030" undersize.

7) To install bearings, ensure crankshaft journal and bearing surface in cap and block are clean. Lubricate journal and install bearing in cap. If bearings were removed with crankshaft still installed, use bearing removal and installation tool inserted in crankshaft oil hole to install upper bearing half. To install rear upper main bearing, place in position and use plier procedure, as previously described, to install bearing. Install main caps noting identification marks and evenly tighten main bearing bolts.

THRUST BEARING ALIGNMENT

Pry crankshaft forward as far as possible and check crankshaft end play with a feeler gauge inserted between front of rear main bearing and crankshaft. Replace rear main bearing if end play not to specifications.

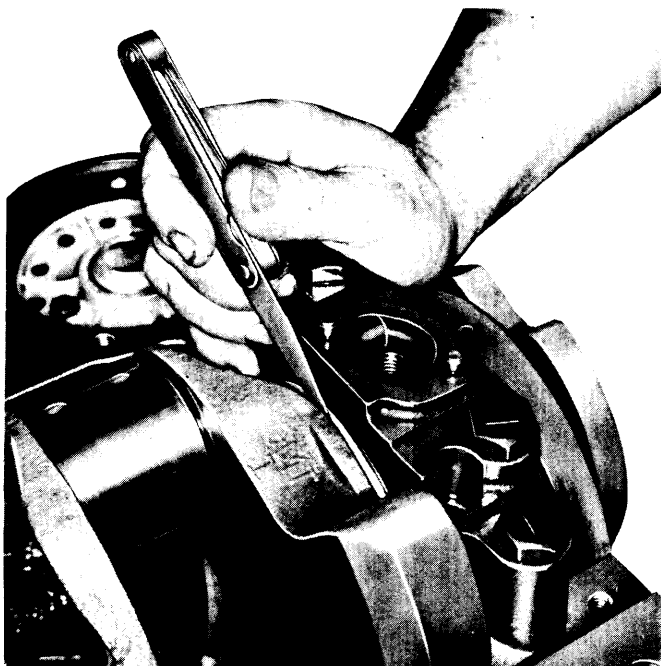

9GMO6

CHECKING CRANKSHAFT ENDPLAY

REAR MAIN BEARING OIL SEAL

Removal — Remove rear main bearing cap and pry out old seal. Remove upper half of seal by tapping end with brass punch until end of seal protrudes enough to be removed with pliers.

Installation — 1) Fabricate installation tool as shown in illustration. Coat seal lips and seal bead of upper seal with motor oil. Keep ends of seal dry of oil and position tool between crankshaft and seal seat in cylinder block. Position seal between tip of tool and crankshaft.

2) Roll seal around crankshaft, using tool as a "shoehorn" to protect seal from sharp corner of seal seat surface. Make sure that oil seal lip is positioned towards front of engine. *NOTE* — Installation tool must remain in position until seal is positioned with both ends flush with block. Remove tool taking care not to remove seal.

3) Install lower half of seal in bearing cap, using tool as a "shoehorn". Feed seal into cap using light pressure with thumb and finger. Install bearing cap with sealant applied to face, taking care to keep sealant off of split line.

4GMO7

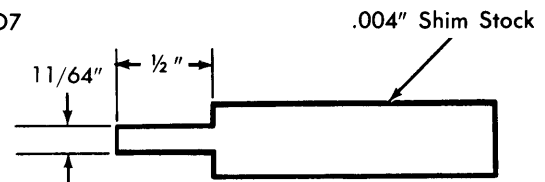

REAR MAIN OIL SEAL INSTALLATION TOOL

ENGINE FRONT COVER

Removal — Remove fan belt, fan and pulley. Remove radiator shroud and accessory drive pulley. Remove harmonic balancer pulley bolt (if equipped). Pull off harmonic balancer with a suitable puller (J-23523). Remove front cover retaining screws and remove cover and gasket.

Installation — Make sure that gasket surface on cover and cylinder block are clean. Coat front cover oil seal with oil and install cover with gasket coated with sealer and evenly tighten screws. Install harmonic balancer and pull into position with a suitable puller (J-23523) or drive into position with a suitable driver and a hammer. To install remaining components, reverse removal procedure.

FRONT COVER OIL SEAL

With Cover Removed — Pry seal out of cover with a screwdriver. Install new seal with open end of seal toward inside of cover and drive into position with a suitable driver (J-23042) and a hammer. Support cover at seal area before driving in seal.

With Cover Installed — With harmonic balancer removed, pry seal out front of cover. Install seal with open end of seal toward engine and drive into place with a suitable driver (J-23042) and a hammer.

General Motors 6 Engines

1965-74 194", 230", 250", 292" 6 CYL. ENGINES (Cont.)

CAMSHAFT			
Engine	Journal Diam.	Clearance	Lobe Lift
1965			
194" & 230"	1.8687-1.8692"	.0015-.0035"	.1914"
292"	1.8687-1.8692"	.0015-.0035"	.2280"
1966-74			
194" & 230"	1.8682-1.8692"	.0015-.0035"	.1896"
250"	1.8682-1.8692"	.0015-.0035"	.2217"
292"	1.8682-1.8692"	.0015-.0035"	.2315"

CAMSHAFT

Removal — 1) Drain cooling system and remove radiator. Remove front grille assembly. Remove valve cover and loosen all rocker arm nuts. Rotate rocker arms to side and withdraw all push rods.

2) Remove coil, side cover and all valve lifters. Remove front engine cover as previously outlined. Rotate engine until timing marks on camshaft gear and crankshaft gear are aligned. Remove distributor, noting position of rotor. Remove two camshaft thrust plate screws and carefully pull camshaft out front of engine to remove.

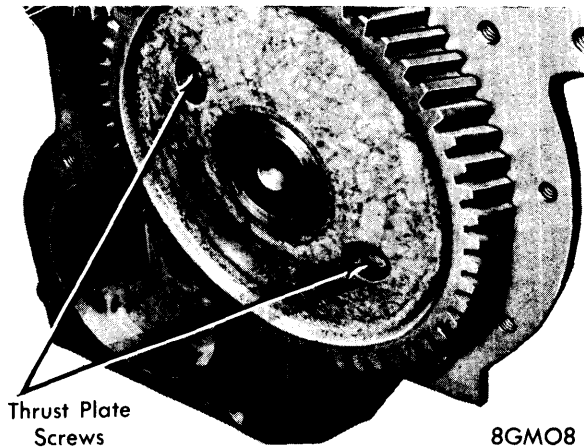

Thrust Plate
Screws

8GMO8

CAMSHAFT THRUST PLATE SCREWS

Installation — To install camshaft, reverse removal procedure. Carefully install camshaft in cylinder block to prevent damage to camshaft lobes or bearings. Make sure marks on timing gears are aligned (see illustration).

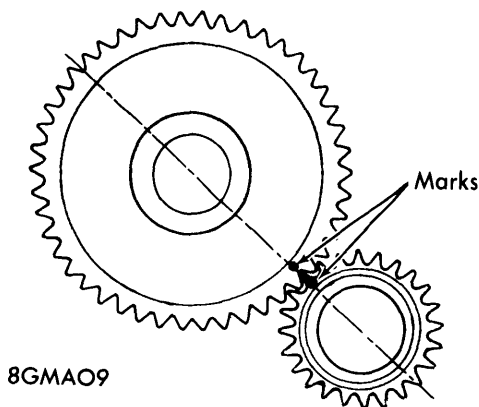

8GMA09

TIMING GEAR MARKS

TIMING GEARS

With camshaft installed, check gear backlash with a narrow feeler gauge. If backlash is less than .004" or exceeds .006", timing gears must be replaced. Check both gears for runout with a dial indicator. If camshaft gear runout exceeds .004", or crankshaft gear runout exceeds .003", gears must be replaced.

Removal — With camshaft removed, position camshaft and a suitable mandrel (J-971) in a press and press camshaft out of gear. Make sure thrust plate is positioned so that Woodruff key will not damage it when camshaft is pressed out of gear. To remove crankshaft gear from crankshaft pull off with a suitable puller.

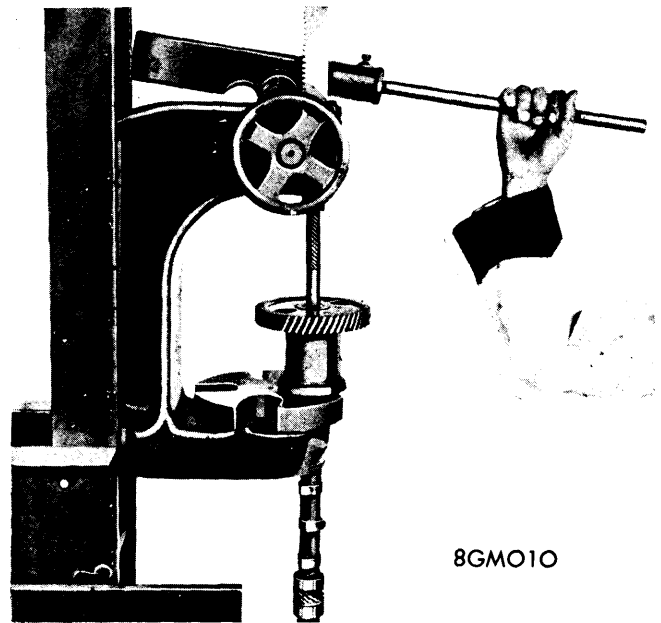

8GMO10

PRESSING CAMSHAFT FROM GEAR

Installation — To install crankshaft gear, align gear on key and drive gear onto crankshaft with a suitable driver. To install camshaft gear, position camshaft in a press with camshaft supported at back of front journal. Place gear spacer ring and thrust plate over camshaft and install Woodruff key in keyway. Press gear onto shaft until clearance between thrust plate and gear is .001-.005".

CAMSHAFT BEARINGS

Use suitable tools for removal and installation and note the following:

Front Bearing — Front bearing must be driven approximately $\frac{1}{8}$ " behind front of cylinder block to uncover oil hole to timing gear oil nozzle.

Rear Bearing — Rear bearing installed position is flush with inner edge of rear cam bearing bore in block.

All Bearings — All cam bearing oil holes must be aligned with oil hole in cam bore.

1965-74 194", 230", 250", 292" 6 CYL. ENGINES (Cont.)

CAMSHAFT END THRUST

Check camshaft end play with a feeler gauge (see illustration). If end play exceeds .005", gear, thrust plate or both must be replaced.

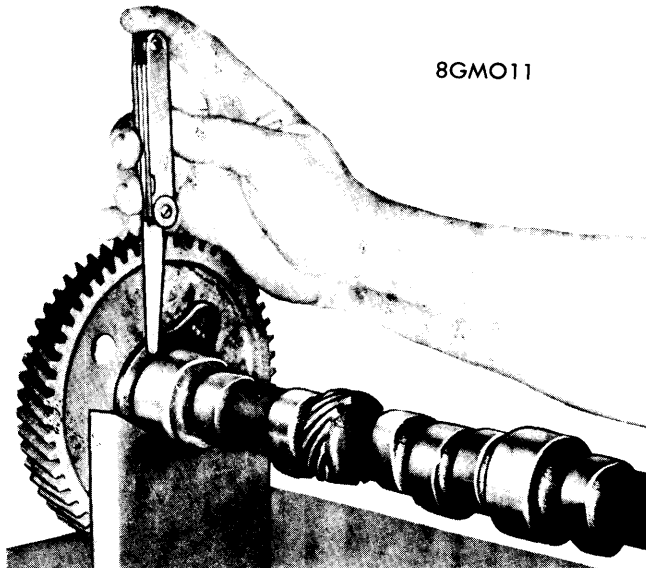

CHECKING CAMSHAFT END PLAY

CAM LOBE LIFT

With valve cover removed, remove rocker arm. Mount dial indicator on rocker arm stud and position dial indicator stem on push rod using a suitable ball adapter (J-8520). Rotate engine slowly until lifter is on heel of camshaft and set dial indicator to 0. Rotate engine slowly until push rod is at fully raised position. Dial indicator will give total camshaft lobe lift. Lift should be within specifications.

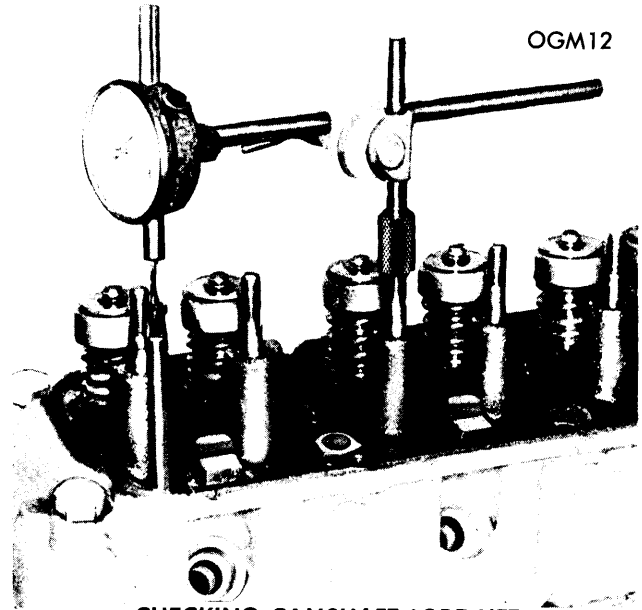

CHECKING CAMSHAFT LOBE LIFT

ENGINE OILING

Crankcase Capacity — All engines (except 292") 4 quarts. All 292" engines 5 quarts. On all engines, add 1 quart with filter change.

Oil Filter — Replaced every other oil change or more often under dusty or severe conditions.

Application	Oil Pressure	Lbs. @ RPM
All (1965-67)	30-40	@ 1500
All (1968-70)	50-65	@ 2000
All (1971-74)	40	@ 2000

ENGINE OILING SYSTEM

Oil pump mounted on right lower flange of crankcase in oil pan draws oil from pan through a floating screen and delivers oil through passage in pump body and crankcase to full flow filter on right side of engine. Oil flows from filter to main oil gallery in block and is distributed as detailed below. Pressure regulator valve is located in oil pump and a by-pass valve is located in filter base.

Crankshaft & Camshaft Bearings — Each main and camshaft bearing is fed oil by a passage extending through crankcase webs from main oil gallery.

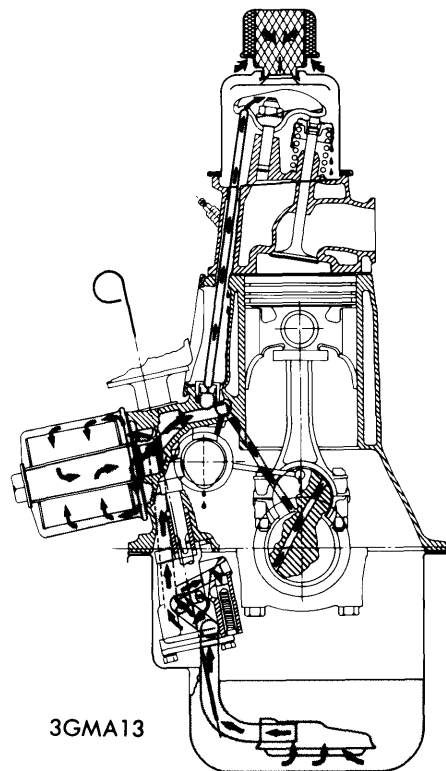

ENGINE OILING SYSTEM

General Motors 6 Engines

1965-74 194", 230", 250", 292" 6 CYL. ENGINES (Cont.)

ENGINE OILING (Cont.)

Connecting Rods & Pistons — Oil is delivered from each main bearing to adjacent connecting rod bearing through drilled passages in crankshaft. A hole in connecting rod sprays oil onto cylinder walls for pistons and pin lubrication, when holes in rod and journal index. Oil hole in rod is towards camshaft side of engine.

Valve Lifters — Main oil gallery intersects lifter bores and lifters are supplied with oil directly from gallery. Lifter has metering valve directly below hole in push rod seat to permit oil to pass into hollow push rod.

Rocker Arms & Valve Stems — Oil passes up through hollow push rods to a hole in upper end of push rods that matches hole in rocker arm. Oil sprayed from this hole and across rocker arm lubricates valve stem tip. Oil in rocker arm chamber drains down through push rod holes to valve lifter chamber, then returns to crankcase through drain holes.

Timing Gears — Lubricated by oil flow from nozzle pressed in front face of block above crankshaft gear. Oil is fed to nozzle through cross-passage from front camshaft bearing.

Distributor Drive Gear — Lubricated by oil drainage from valve lifter compartment (drain hole directs oil onto gears).

DISTRIBUTOR DRIVE SHAFT LOWER BEARING

Bushing pressed into lower side of cylinder block (with or without thrust washer at upper end) and serves as lower bearing for distributor shaft (inside diameter), and as pilot for oil pump shaft (outside diameter). Replace bushing (and thrust washer) when distributor shaft-to-bushing clearance exceeds .0035".

Removal — Use Tool J-9534 and slide hammer to remove bearing. Drive out thrust washer with suitable drift.

Installation — Drive new thrust washer into place with Tool J-9535. Using Tool J-9535 with driver-bolt in the driver handle, install driver into new bushing from large inside diameter. Drive bushing into position.

NOTE — Proper position of bushing is determined when tool bottoms against cylinder block. Withdraw tool from bushing. If bushing siezes on installer arbor, remove tool with slide hammer. Bushing will not be damaged and tool is designed for this purpose.

OIL PUMP

Removal — Mark gears so they may be reassembled with the same teeth indexing. Do not disturb pickup screen on pipe. Screen is serviced as an assembly. **NOTE** — If pump gears or body are damaged or worn, replacement of entire pump assembly is required.

Installation — Apply sealer to end of pipe and tap into place. Install idler gear in pump body with smooth side of gear toward cover opening. **NOTE** — Bottom of screen must be parallel with bottom of pan.

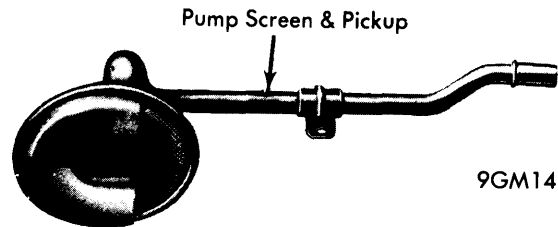
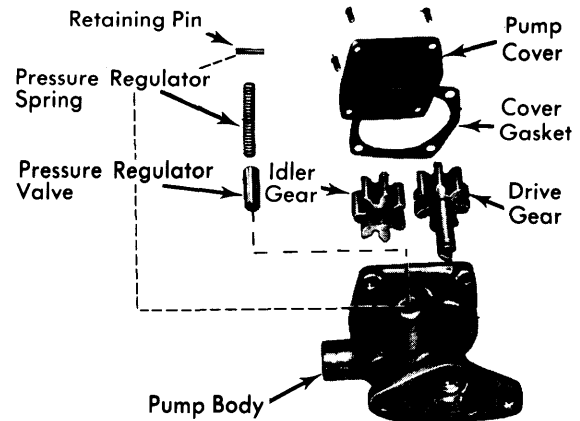

ENGINE OIL PUMP (TYPICAL)

TIGHTENING SPECIFICATIONS

Application	Ft. Lbs.
Cylinder Head	95
Intake & Exhaust Manifold Assy.	
1965-71 (Outer).....	20
1965-71 (Inner).....	30
1972-74 (All).....	30
Main Bearing Cap Bolts.....	65
Connecting Rod Nuts	
All (Exc. 292").....	35
292".....	40
Camshaft Thrust Plate.....	80 INCH Lbs.
Flywheel Bolts	
All (Exc. 1967-74 292").....	60
1967-74 292".....	110
Harmonic Balancer Bolt (292" Only).....	60