

SUBARU 4-WD REAR AXLE

DESCRIPTION

The rear axle assembly of all 4-WD vehicles is a hypoid type with integral carrier housing. The pinion bearing preload adjustment is made by a selective spacer and washer.

The differential side bearing preload and pinion depth adjustments are made with shims. Driving power is transmitted to rear axle by ball spline type drive shafts with constant velocity (CV) joints at each end.

AXLE RATIO & IDENTIFICATION

All 4-WD vehicles use one basic type rear axle assembly. To determine axle ratio, divide number of ring gear teeth by number of pinion teeth.

REMOVAL & INSTALLATION

AXLE SHAFT & BEARINGS

Removal

1) Apply hand brake. Remove wheel cap and cotter pin. Loosen castle nut and wheel nuts. Disconnect lower bolt of shock absorber. Loosen locking bolts of crossmember outer bushing.

2) Raise and support vehicle. Remove wheel and tire assembly. Remove castle nut and brake drum.

3) Drive out spring pins of inner and outer Double Offset Joint (DOJ) by using 6 mm diameter steel rod. Remove outer DOJ from spindle of trailing arm with trailing arm lowered fully. Remove inner DOJ from differential spindle.

Fig. 1: Sectional View of Rear Drive Axle Assembly

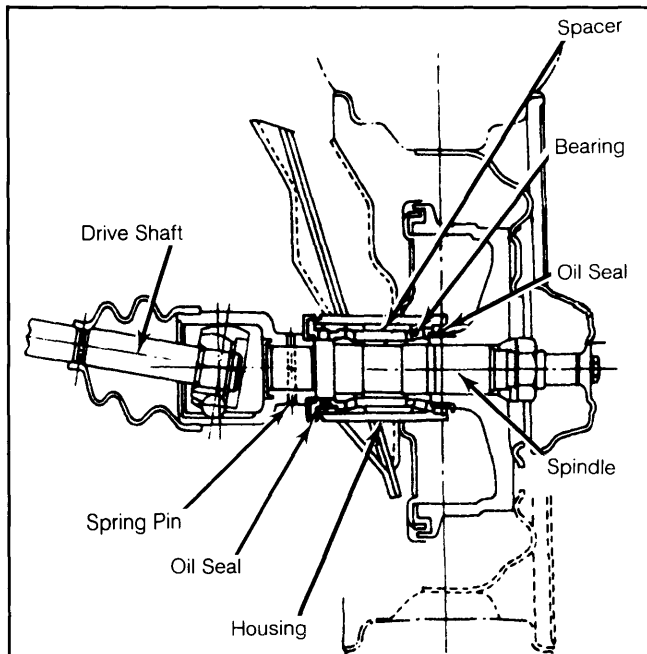

4) Remove rear exhaust pipe, muffler and covers. Disconnect brake line and plug end. Remove brake assembly from trailing arm by removing 4 bolts.

5) Remove bolt from inner bushing of inner trailing arm. Remove 3 bolts from inner arm and outer arm, remove inner arm.

6) Place inner arm in vise. Straighten staked portion of housing. Remove ring nut and remove spindle inward by tapping from outside with a soft hammer.

7) Remove oil seal. Insert spindle from outside of housing and press outer bearing out by pushing inner race through housing. Press out inner race of spindle.

Fig. 2: Driving Spring Pins Out of Double Offset Joint

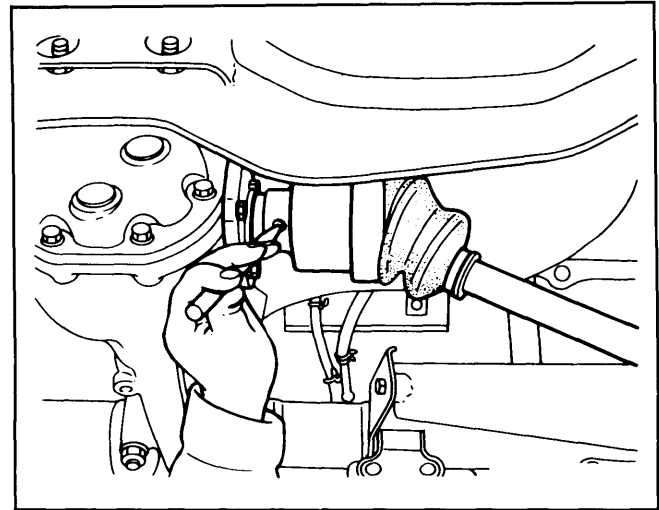

Drive out springs of double offset joint using a 6 mm diameter steel rod.

Installation

To install and reassemble, reverse removal procedures, noting the following: Assemble using new seals and lubricate all bearings and joints.

PINION FLANGE & OIL SEAL

Removal

1) Drain gear oil from differential. Raise and support rear of vehicle. Disconnect propeller shaft from pinion flange. Measure and record turning torque of pinion flange.

2) Hold pinion flange with flange wrench. Remove pinion nut. Remove pinion flange with puller and remove oil seal.

Installation

1) Apply grease between oil seal lips. Install oil seal using drift. Install pinion flange.

Fig. 3: Drive Pinion Nut Removal

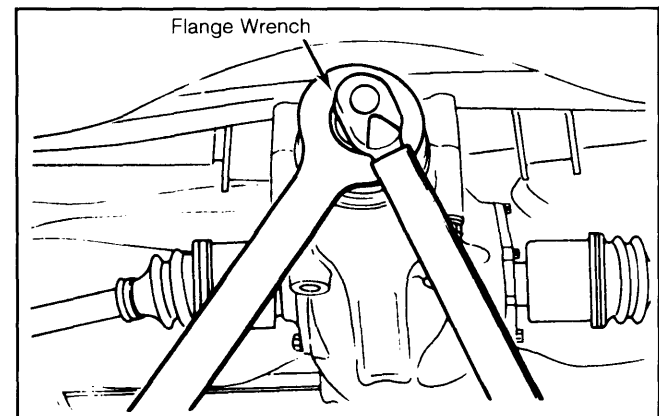

Hold pinion flange from turning with flange wrench.

Drive Axles

SUBARU 4-WD REAR AXLE (Cont.)

2) Hold flange with flange wrench and tighten nut until turning torque is same as recorded before removal. Install remaining components in reverse order of removal procedure.

DIFFERENTIAL ASSEMBLY

Removal

1) Raise and support rear of vehicle. Drain gear oil. Remove exhaust pipe, muffler, propeller shaft and drive shafts.

2) Support axle assembly with a jack. Remove nuts on mounting member. Remove 2 bolts retaining front end of differential carrier. Lower jack and remove axle assembly.

Installation

To install, reverse removal procedure and note the following: Tighten bolts to specification and fill unit with gear oil.

OVERHAUL

DRIVE AXLE SHAFT

Disassembly

Hold drive shaft in a vise and remove rubber boot. Remove snap ring and stopper, then disassemble ball spline. Remove snap ring, needle bearing and universal joint.

Inspection

1) Check rubber boot and oil seals for damage and replace as necessary. Inspect drive shaft for straightness, cracks, damage and distortion. Replace drive shaft if ball spline portion is worn or damaged.

2) Check drive shaft play at ball spline and free play of needle bearing. Maximum play of ball spline is .04" (1 mm).

Fig. 4: Exploded View of Drive Axle Shaft

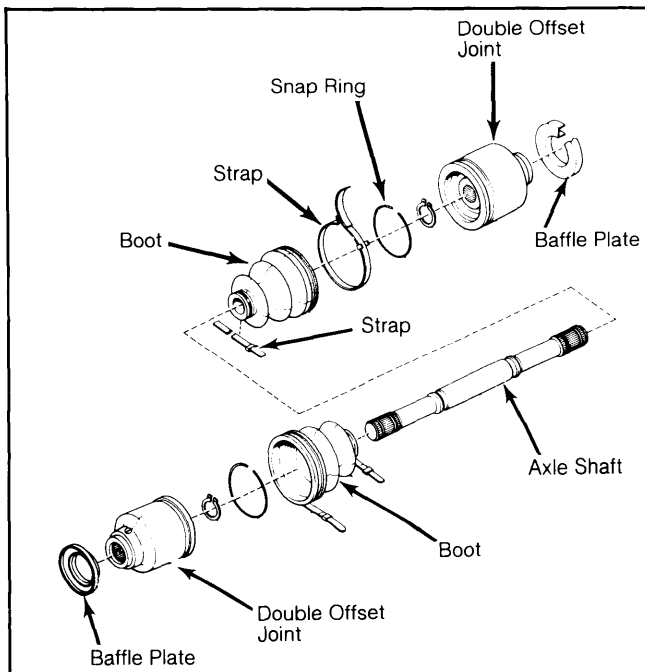

Drive axle shaft should be disassembled only to lubricate ball spline.

Reassembly

1) To reassemble, reverse disassembly procedure and note the following: Apply grease to points shown in Fig. 5. Install rubber boot and adjust drive shaft length to 13.15" (334 mm).

2) Adjust axial play to within .0008" (.02 mm) by selecting proper size snap ring. Tighten all bolts.

Fig. 5: Drive Axle Shaft Grease Locations

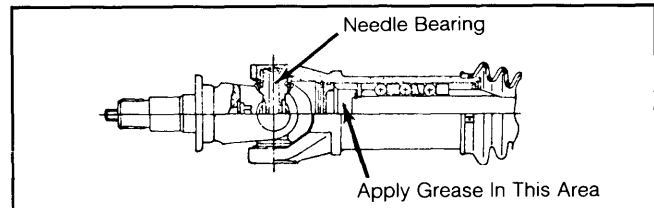

Adjust drive shaft length to 13.15" (334 mm).

DIFFERENTIAL CASE

NOTE: Mark side retainers for reassembly reference. Left and right retainers are not interchangeable.

Disassembly

1) Mount carrier on holding fixture and remove cover plate. Using puller, remove side retainer. Remove differential case assembly from carrier.

2) If side bearings are to be replaced, remove bearing outer races from side retainers with puller.

3) Hold pinion flange stationary and remove pinion nut. Remove pinion flange with puller. Press drive pinion from carrier and remove rear bearing inner race, bearing spacer and adjusting washer.

4) Remove side bearings from differential case with puller. Remove ring gear by unfolding lock strap and loosening bolts. Unstake pinion shaft lock pin and punch pin out from flange side.

5) Remove pinion shaft, pinion gears, side gears and thrust washer. Thoroughly clean all parts and inspect for wear or damage; replace as necessary.

Reassembly & Adjustment

1) Assemble pinion gears, side gears and thrust washers in original positions in differential case. Fit pinion shaft to differential case so that it aligns with lock pin holes.

2) Adjust clearance between differential case and back of side gear to .004-.008" (.1-.2 mm) by selecting proper thrust washer. Thrust washers are available in the following sizes, .030-.032" (.75-.80 mm), .032-.034 (.80-.85 mm), and .034-.036" (.85-.90 mm).

3) Install pinion shaft lock pin and lock in place on both sides. Apply gear oil to gear tooth surface and thrust surfaces and make sure gears rotate smoothly. Install ring gear on differential case and install bolts and new lock washers.

NOTE: Tighten ring gear bolts diagonally while tapping around bolt heads with a hammer.

4) When replacing side bearings, measure bearing width by using a weight block of approximately 5.5 lbs. (2.5 kg). Standard Bearing width is .787" (20 mm).

5) Press side bearing inner race onto differential case and bearing outer race into side retainer. Install

SUBARU 4-WD REAR AXLE (Cont.)

Fig. 6: Measuring Side Bearing Width

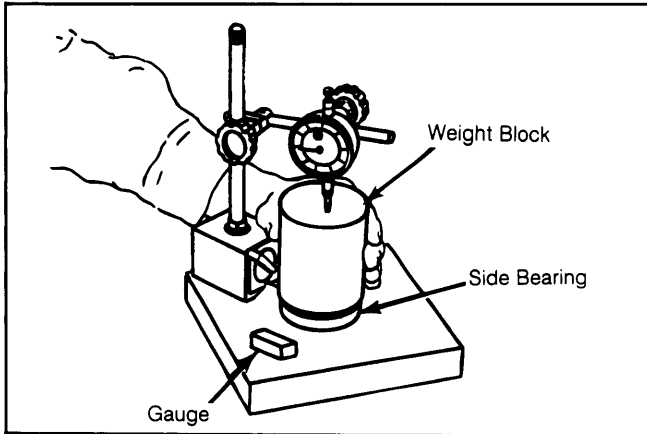

Standard bearing width is .787" (20 mm).

new oil seal on side retainer and apply grease to cavity between seal lips.

Drive Pinion Bearing Preload Adjustment

1) Press front and rear bearing outer races into carrier. Install dummy pinion shaft with rear bearing and pinion depth washer into the carrier.

2) Install preload adjusting spacer and washer, front bearing inner race, dummy collar, companion flange

and nut onto dummy shaft. Do not install oil seal. Rotate pinion by hand until it is seated.

NOTE: Do not exceed specified preload torque during preload adjustment.

3) Tighten nut to specified torque. Using an INCH lb. torque wrench, check rotating torque of pinion shaft. If preload is not within specification, select the correct washer and spacer so that specified preload is obtained when nut is tightened to correct torque.

Fig. 8: Installing Dummy Shaft

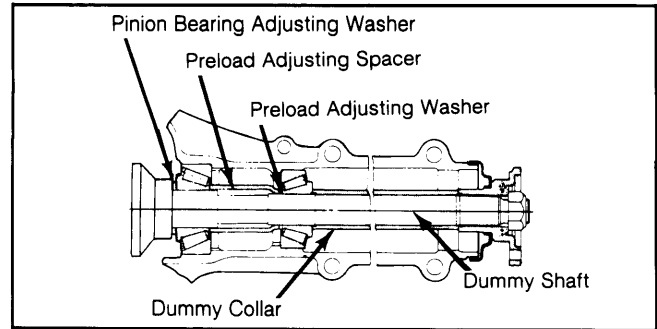

If ring and pinion gear tooth contact pattern show normal pattern, reuse original washer.

Fig. 7: Exploded View of Subaru 4-WD Differential Assembly

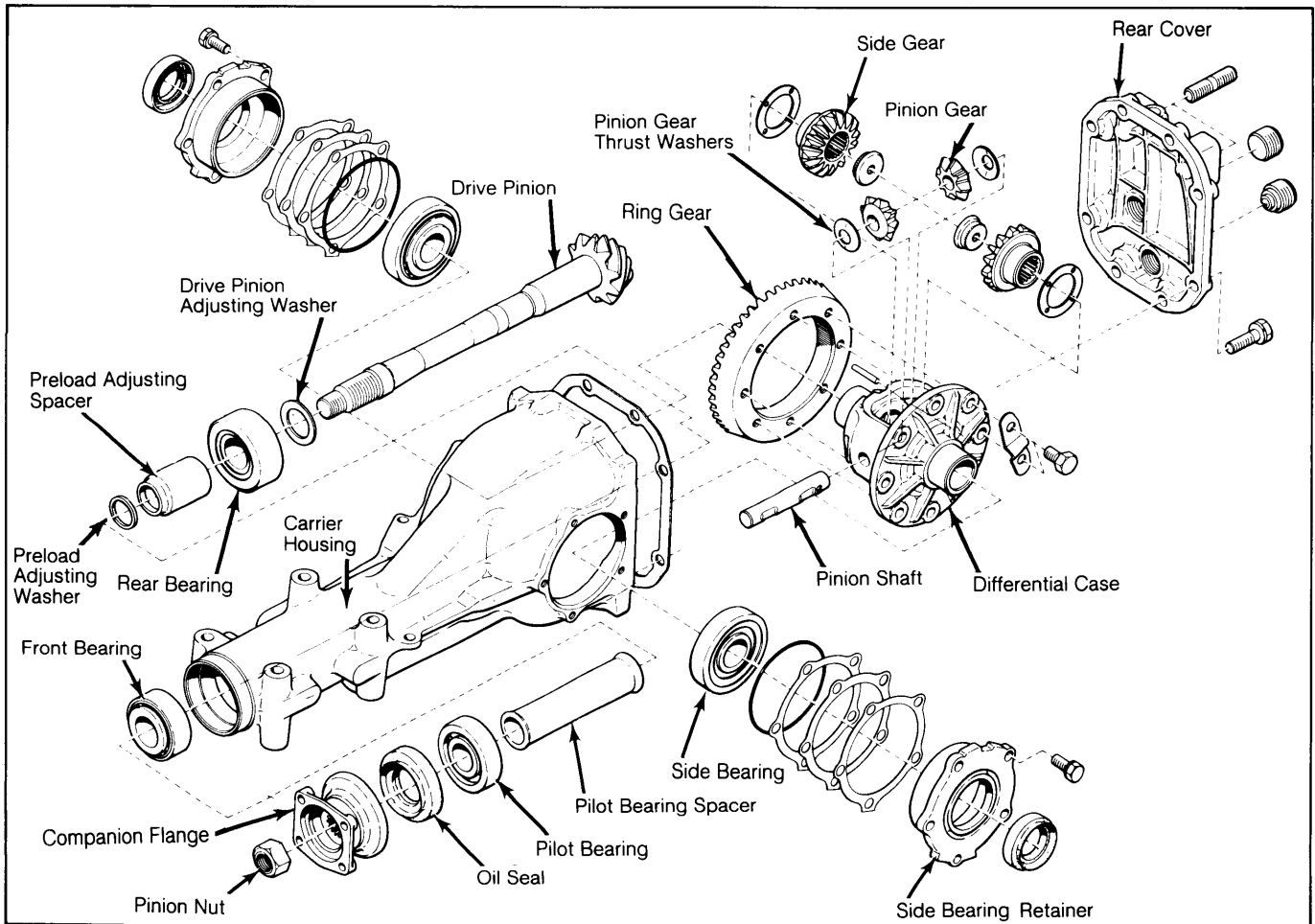

Drive Axles

SUBARU 4-WD REAR AXLE (Cont.)

4) Spacers are available in lengths from 2.213" (56.2 mm) to 2.252" (57.2 mm) in increments of .008" (.20 mm). Washers are available in thicknesses from .102" (2.59 mm) to .0909" (.231 mm) in increments of .0008" (.02 mm).

Drive Pinion Gear Installed Height

1) Leave dummy drive pinion shaft installed and install height gauge. See Preload Adjustment. Measure clearance between end of pinion gear head and height gauge using feeler gauge.

2) Determine the thickness of the pinion height adjusting washer to be installed using the following formula.

NOTE: Formula values are given in millimeters.

$$T = T_o + N - (H \times .01) - .20$$

T = Thickness of adjusting washer needed.

T_o = Thickness of washer temporarily installed.

N = Clearance between gauge and dummy shaft.

H = Figure marked on drive pinion head.

2) After determining the correct thickness of required pinion height adjusting washer, remove dummy shaft and height gauge. Install pinion height adjusting washer on drive pinion, then press rear bearing inner race into position.

3) Insert drive pinion into gear carrier. Install previously selected preload adjusting spacer, washer, oil seal, companion flange, and pinion nut. Tighten pinion nut to specification.

Fig. 9: Measuring Drive Pinion Gear Installed Height

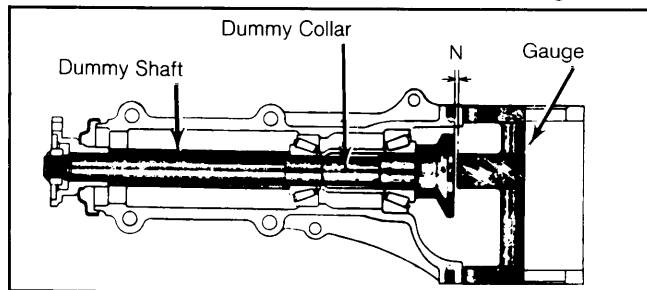

Measure clearance (N) between end of pinion gear head and height gauge using a feeler gauge.

Side Bearing Preload

1) Use the following formula to obtain the proper thickness of left and right side retainer shims.

NOTE: Formula values are given in millimeters.

$$T_1 \text{ (Left)} = (A + C + G_1 - D) \times .01 + .76 - E$$

$$T_2 \text{ (Right)} = (B + D + G_2) \times .01 + .76 - F$$

T₁ = Required thickness of left side retainer shim.

T₂ = Required thickness of right side retainer shim.

A & B = Figure marked on gear carrier.

C & D = Figure marked on differential case.

E & F = Difference in width of left or right bearing.

G₁ = Figure marked on left side retainer.

G₂ = Figure marked on right side retainer.

Fig. 10: Location of Identification Marks

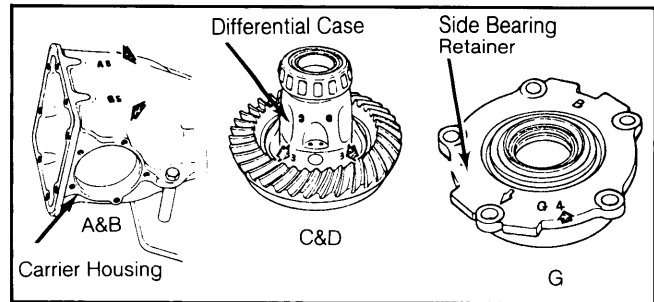

If the identification mark is not present, regard it as zero.

2) Install differential case assembly into differential carrier in reverse order of disassembly. Fit selected shims and "O" ring on the side retainer and install retainers in carrier with arrow pointing as shown in Fig. 11.

Fig. 11: Aligning Side Retainer

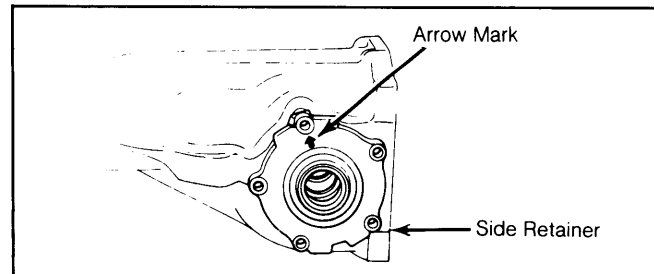

Arrow must point as shown for proper alignment.

3) Measure drive gear-to-drive pinion backlash. If reading is not within specification, correct by decreasing the shim thickness on one side and increasing the shim thickness on other side the same amount. Total shim thickness must be the same to maintain proper preload.

AXLE ASSEMBLY SPECIFICATIONS

Application	Specification
Pinion Bearing Preload	
New Bearing	4.4-6.4 Ft. Lbs. (6.0-8.7 N.m)
Used Bearing	1.9-3.7 Ft. Lbs. (2.6-5.0 N.m)
Side Bearing Clearance	.004-.008" (.1-.2 mm)
Drive Gear-to-Pinion Backlash	.004-.008" (.1-.2 mm)
Drive Gear Backface Runout ¹	.002" (.05 mm)

¹ — Maximum Clearance.

TIGHTENING SPECIFICATIONS

Application	Ft. Lbs. (N.m)
Pinion Nut	123-145 (167-197)
Ring Gear Bolts	51-58 (69-79)
Side Bearing Retaining Bolt	7-9 (9-12)
Side Yoke Retaining Bolt	14-19 (19-26)
Rear Cover Bolts	14-19 (19-26)
Front Carrier Mounting Bolts	58-72 (79-98)
Rear Carrier Mounting Bolts	43-51 (58-69)
Propeller Shaft Flange Bolts	13-18 (18-24)
Companion Flange Bolts	13-18 (18-24)
Axle Nut	174 (237)
Rear Drive Shaft Spindle Ring Nut	130-160 (177-217)