

Drive Axles

JAGUAR

XJ6, XJS

DESCRIPTION

The differential assembly is of hypoid ring and pinion design with center line of drive pinion gear set below centerline of ring gear. A collapsible spacer is used to set drive pinion bearing preload and all other differential adjustments are accomplished using shims.

Stub axles transmit power out of differential, through independent rear suspension, to drive wheels. A clutch pack limited slip unit, "Powr-Lok", is used on some models.

AXLE RATIO & IDENTIFICATION

Jaguar uses an integral carrier rear axle which may be equipped with a "Powr-Lok" differential. "Powr-Lok" can be identified by the letters "PL" on a tag under the axle cover bolt.

Two different axle ratios are used. A 3.07:1 gear ratio is used as standard on 12 cylinder models and as an alternative on six cylinder models. A 3.31:1 gear ratio is used as standard on six cylinder models. To determine axle ratio, divide number of ring gear teeth by number of pinion gear teeth.

REMOVAL & INSTALLATION

REAR SUSPENSION ASSEMBLY

NOTE: This procedure is provided since many operations on the final drive require removal of rear suspension assembly before starting work on final drive.

Removal

1) Raise and support vehicle. Place stands forward of radius arms on body with wood blocks between body and stands. Remove wheels. Remove mufflers from tail pipes.

2) Remove safety wire and bolts securing safety strap to body. Remove radius arm securing bolt, safety strap and radius arm from body mounting post. Disconnect and plug brake lines at body.

3) Remove clevis pin securing hand brake cable to actuating levers on crossmember. Loosen lock nut and remove outer hand brake cable screw from adjuster block. Detach drive shaft from differential.

4) Place jack under rear suspension. Remove bolts and lock nuts securing crossmember mounts to frame. Lower and remove rear suspension from vehicle.

Installation

To install, reverse removal procedure and note the following: Bleed brakes. Tighten radius arm nuts on lower control arm when weight of vehicle is on wheels.

HALF SHAFT

Removal

1) Remove rear suspension assembly. Remove rear hub as follows. Remove fulcrum shaft grease fitting. Withdraw cotter pin and remove nut and washers from splined end of half shaft. Using puller, pull hub and carrier from half shaft.

Fig. 1: Hub and Carrier Assembly Removal from Half Shaft

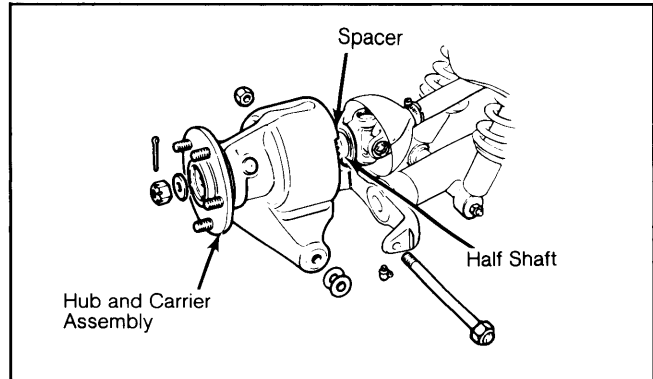

A puller must be used to remove hub and carrier from half shaft.

2) Remove spacer from half shaft and examine inner oil seal track. Replace track if necessary. Remove 1 nut from outer suspension arm fulcrum shaft and using soft hammer, drift out shaft. Remove hub and carrier assembly from car.

3) Support suspension arm with jack and remove nut and bolt securing top of forward shock absorber. Remove nuts and washer securing shock absorber to suspension arm and remove shock. Remove 4 nuts securing half shaft flange to stub axle flange and brake rotor.

4) Pull half shaft from suspension unit noting number of camber shims installed between half shaft flange and brake rotor. If necessary, remove joint shields by drilling out rivets.

Fig. 2: View of Half Shaft with Hub and Carrier Assembly Removed.

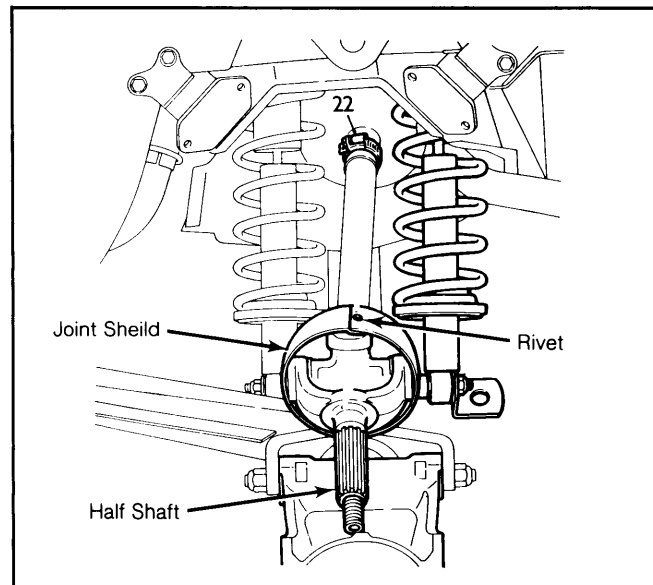

If necessary drill out rivets to remove joint shields.

Installation

1) To install, reverse removal procedure, noting the following: If necessary, replace joint shield, positioning grease nipple access hole correctly.

JAGUAR (Cont.)

2) Cover joint lines in shield with non-hardening waterproof sealing compound. Be sure to replace camber shims.

3) To reinstall rear hub, proceed as follows. Install dummy shaft in hub carrier fulcrum. Install carrier on suspension arm, installing shims removed from between carrier and suspension arm. Replace outer suspension arm fulcrum shaft, displacing dummy shaft. Secure shaft with nut and reinstall grease nipple.

4) If necessary, install oil seal track to half shaft splined flange, replace spacer. Thoroughly clean and degrease splines of half shaft and bore of hub.

5) Using a small brush, sparingly apply Loctite "Stud Lock" to outer two thirds of half shaft splines. Assemble hub carrier to half shaft. Install washer and tighten hub carrier assembly nut. Install new cotter pin.

6) Install dial indicator so it bears against hub and zero indicator. Using 2 levers, pry out on hub and measure hub bearing endplay. If endplay exceeds specifications, overhaul rear hub and carrier assembly. After installation of rear suspension in vehicle, check rear wheel camber.

STUB AXLE OIL SEAL

NOTE: To remove stub axle it is necessary to remove the inboard end of the drive shaft, the forward attachment of the radius rod, and the brake caliper and disc.

Removal

1) Remove half shaft. Remove locking wire securing caliper mounting bolts. Remove caliper mounting

bolts and caliper. Remove brake rotor, noting number of shims removed between rotor and stub axle flange. Remove lock wire and 5 bolts securing caliper mounting flange (bearing housing) to final drive.

2) Withdraw stub axle, together with caliper mounting shims, bearings and oil seal. Discard oil seal. Turn down tab washer and remove nut from stub axle. Remove bearings and caliper mounting flange from stub axle.

Installation

1) Lightly oil new seal and position carefully in drive case. Press seal squarely and fully seat in case groove. DO NOT remove protruding portion of seal.

2) Coat seal with hypoid oil and place caliper mounting flange and seal assembly over stub axle. Slide bearings on drive shaft followed by new tab washer and nut. Ensure bearings seat square to stub axle shoulder and tighten nut. Turn tab up on washer.

3) Lightly oil stub axle splines and install shaft in final drive housing. Install bolts securing mounting bracket finger tight. Using feeler gauge, measure dimension between inside face of mounting bracket and final drive housing.

4) The measurement obtained determines shim thickness required. Remove stub axle and select shims of required thickness, and thinly coat mating faces and shims with sealant. Tighten bolts in a diagonal sequence.

5) Wire lock securing bolts to tension in clockwise direction. Install brake rotors and half shaft flange, using shims removed from between rotor and flange. Install caliper on mounting bracket.

6) Install distance spacers (oversize nuts) to rotor studs and tighten nuts. Use feeler gauges to ensure that rotor is centrally located between jaws of caliper. If necessary add to or remove from shim pack between flange and disc to center rotor. Continue assembly in reverse of disassembly procedure.

PINION FLANGE & SEAL

Removal

1) Disconnect propeller shaft. Check and record torque required to turn drive shaft flange clockwise (viewed from front) through backlash movement.

2) Block rear wheels and remove flange securing nut and washer. Remove flange. Pry oil seal out of final drive case. Lightly score oil seal recess with tang of file.

Installation

1) Ensure oil seal recess is clean and free of oil. Lightly tap new oil seal into recess ensuring seal is square with case. Reinstall flange, washer and nut.

2) Tighten nut to specifications while rotating flange to ensure bearing seats correctly. Recheck pinion preload.

3) If preload is below specifications, continue tightening flange nut until specified preload is obtained. If preload exceeds maximum specified value, new collapsible spacer must be installed (see differential overhaul). Reconnect propeller shaft and remove wheel chocks.

REAR AXLE ASSEMBLY

Removal

1) Remove rear suspension assembly and drain final drive unit. Remove final drive mounting plate and shock absorber/spring units. Remove nuts securing half shaft inner universal joint to brake rotor.

Fig. 3: Sectional View of Stub Axle Assembly

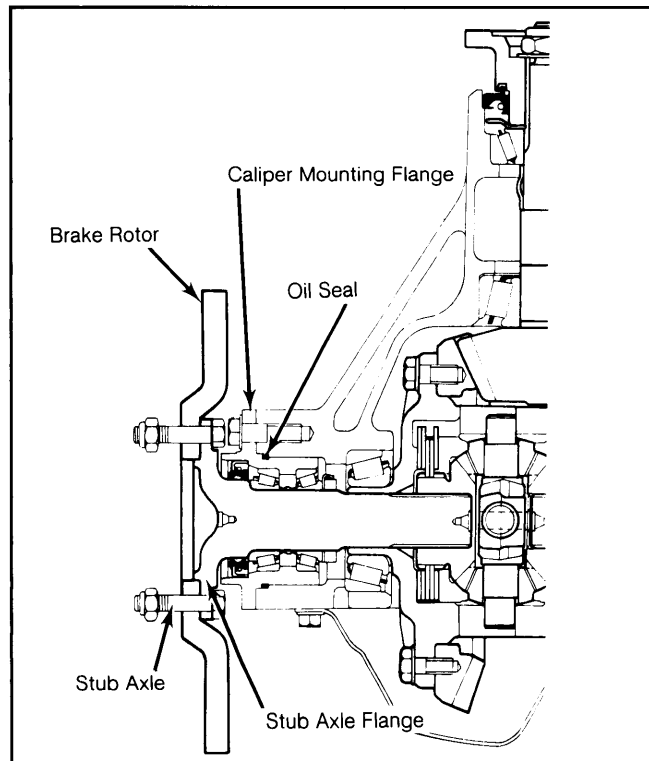

Remove stub axle, caliper mounting shims, bearing, and oil seal as a unit.

JAGUAR (Cont.)

6) Remove bolts securing both halves of differential case. Split case and remove clutch discs and plates from one side.

7) Remove differential side ring, pinion side gear and pinion cross shafts complete with gears. Remove remaining side gear and ring and remove remaining clutch discs and plates.

8) On non "Powr-Lok" differentials only, remove peening and drift pinion shaft lock pin out of carrier. Remove gears, shaft and shims from carrier.

REASSEMBLY & ADJUSTMENT

Case Assembly

1) On "Powr-Lok" differentials, install clutch plates and discs alternately into flange half of case. Install 2 belleville clutch plates so that convex sides are against case.

2) Install side ring and position 1 side gear into ring recess. Install pinion cross shafts complete with pinion gears, ensuring that ramps on shafts coincide with mating ramps in case.

3) Assemble differential case halves ensuring that reference marks are lined up and clutch friction plate tongues are aligned with grooves in differential case. Install bolts, but do not tighten. Check alignment of splines by inserting both stub axles.

4) Tighten differential case bolts with stub axles in position. With 1 stub axle locked, other axle must not turn more than .75" (19 mm) measured on a 6" (152 mm) radius.

5) On non "Powr-Lok" differentials, install pinion shaft, shims and gears into differential carrier. Secure lock pin by peening.

Fig. 5: Exploded View of "Powr-Lok" Differential Clutch Pack and Side and Pinion Gears

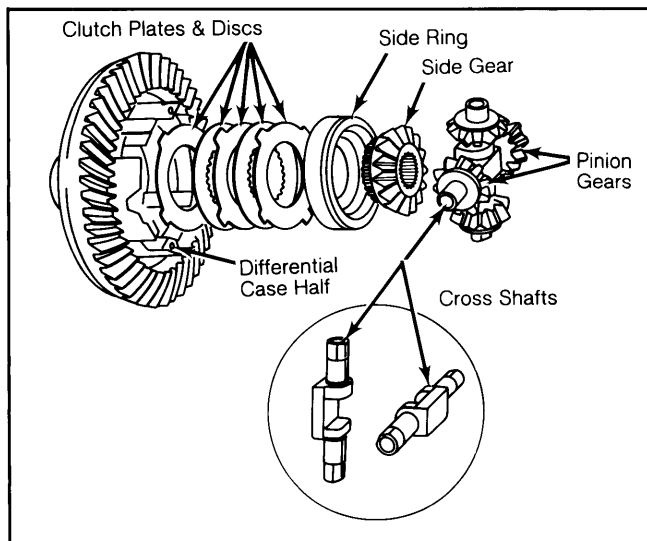

Alternate clutch plates and discs into case.

Side Bearing Preload

1) Install differential side bearing, without shims, on differential case, making sure that bearings and housing are perfectly clean. Place differential assembly in housing.

2) Install dial indicator with indicator leg against back face of ring gear. Using pry bars between

housing and bearing cups, move differential assembly fully to one side of housing.

3) Zero dial indicator and move assembly to other side. Record indicator reading and add .009" (.20 mm) to reading to give total shim pack required. Remove differential assembly from housing.

Fig. 6: Measuring Side Bearing Preload

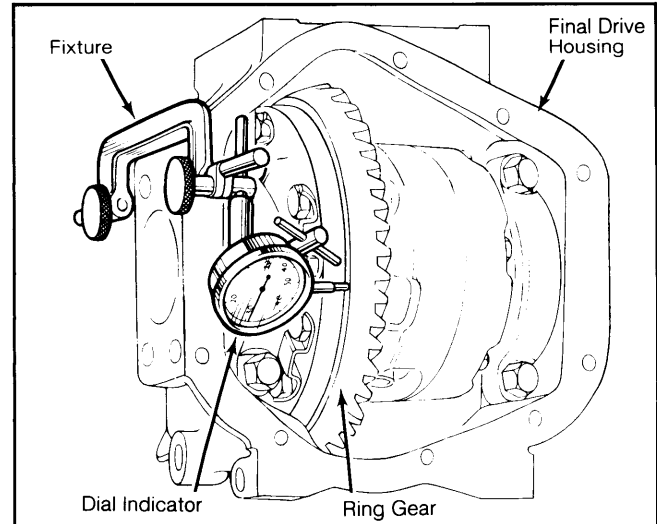

Record indicator reading and add .009" (.20 mm) to give total shim pack required.

Drive Pinion Depth

1) Place pinion, together with inner bearing cone, into housing. Turn housing over and support pinion. Install pinion outer bearing cone, flange, washer and nut, omitting collapsible spacer, oil slinger and oil seal, tighten nut.

2) Using a dial indicator support fixture (SL.3), zero dial indicator on gauge block (4H.A). Place dial indicator fixture firmly on face of pinion and note indicator reading to bottom of housing bearing bore (see illustration).

3) The indicator reading shows deviation of pinion setting from zero cone setting. This value should agree with value etched on face of pinion at bottom.

4) For example, if value etched on pinion is — 2, dial indicator should read —.002". If setting is incorrect, dismantle pinion and remove pinion inner bearing cup. Add or remove shims as required, reassemble and recheck pinion depth.

5) When setting is correct, remove pinion from housing. Remove outer bearing cone. Install collapsible spacer to pinion ensuring that it seats firmly on machined shoulder of pinion. Insert pinion into housing.

6) Install outer bearing cone, oil slinger and oil seal. Lightly grease splines of pinion shaft and install flange. Install new washer on end of pinion with convex side facing end of shaft. Install but do not tighten nut.

Backlash Adjustment

1) Place differential assembly, complete with side bearings but less shims, in housing. Ensure that bearings and housing are clean. Install dial indicator on housing with feeler on back face of ring gear.

2) Pry differential case and ring gear assembly away from pinion until opposite side bearing is seated against housing. Zero dial indicator at this point.

Drive Axles

JAGUAR (Cont.)

Fig. 7: Measuring Drive Pinion Gear Installed Depth

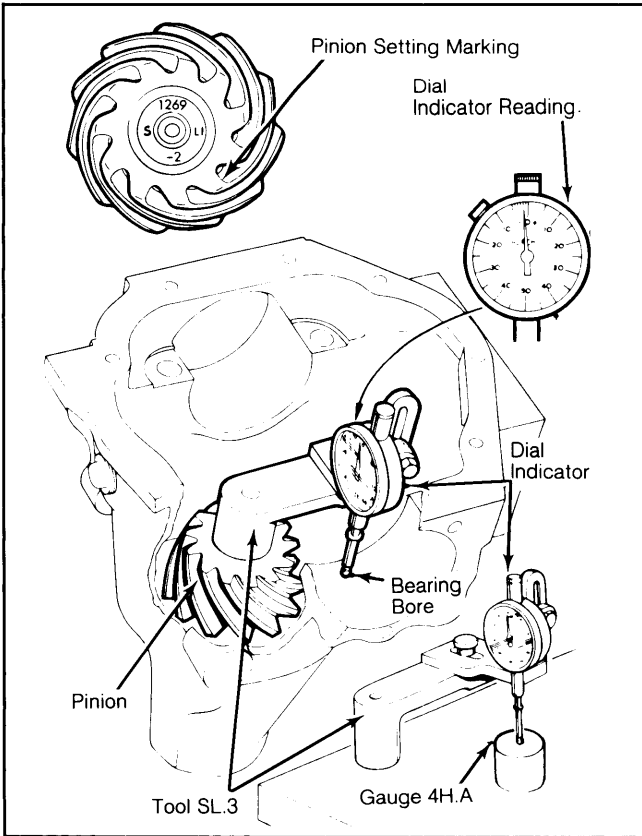

Pinion deviation from zero cone setting is etched on face of pinion.

3) Move differential assembly towards pinion until ring gear is deeply meshed with pinion. Note indicator reading and from this value, subtract the backlash allowance etched on drive gear (eg. B/L.007 denotes .007").

4) This result will yield the thickness of shims (in inches) to be placed between differential case and side bearing on ring gear side of differential.

5) Install this thickness of shims, taking shims from pack determined previously under "Side Bearing Preload". Install balance of total shims required on opposite side of case. An example of calculations required follows:

EXAMPLE:

Side Bearing Preload Reading080"
PLUS Preload Value009"
Total Shim Pack089"
Pinion-to-Ring Gear Clearance042"
MINUS Etched Backlash Value007"
Total Ring Gear Side Shims035"
Total Shim Pack089"
MINUS Ring Gear Side Shims035"
Opposite Ring Gear Shim Pack054"

6) With shims calculated installed, lower differential assembly into position, lightly tapping bearings home with soft hammer. Make sure ring and pinion gears mesh as installation proceeds.

7) Install side bearing caps, ensuring proper cap is placed on proper bearing. Tighten cap bolts. Mount dial indicator on housing with feeler against back face of ring gear.

8) Turn pinion by hand and check ring gear run out. If run out exceeds specifications, disassemble differential, clean all mounting surfaces and check for burrs.

9) Now place dial indicator to measure ring gear backlash. Move ring gear and check that backlash is to the specification etched on ring gear. If backlash is not to specifications, transfer necessary shims from side of differential case to the other.

NOTE: To increase backlash, remove shims from ring gear side and install on opposite side and visa versa. Finally, run a gear tooth contact pattern and adjust shims as necessary.

Pinion Bearing Preload

1) Install pinion and stub axle oil seals. Install stub axles following procedure given under stub axle removal and installation. Tighten flange nut to specified torque. During tightening process, rotate flange to ensure correct seating of taper roller bearings.

2) Use care not to over tighten nut. If nut is over tightened, install a new collapsible spacer as pinion bearing preload will otherwise be incorrect. Install final drive rear cover using new gasket and sealer (Hylomar).

Fig. 8: Measuring Ring Gear-to-Drive Pinion Gear Backlash

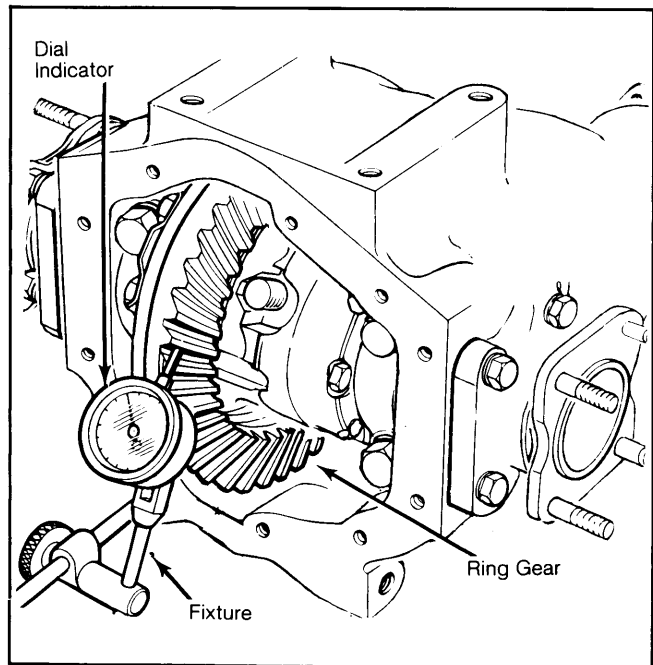

If nut is over tightened a new collapsible spacer must be installed.

Drive Axles

JAGUAR (Cont.)

AXLE ASSEMBLY SPECIFICATIONS

Application	Specification In. (mm)
Rear Hub Bearing Endplay	
Preferred001-.003 (.03-.08)
Acceptable	¹ .005 (.13)
Zero Cone Setting	² 2.625 (66.67)
Drive Pinion Preload	
Preferred001-.003 (.03-.08)
Acceptable	¹ .005 (.13)
Side Bearing Preload	¹ .009 (.23)
Ring Gear Run Out	¹ .005 (.13)

¹ — Maximum clearance.
² — Distance from centerline of differential bearing bores to pinion face.

TIGHTENING SPECIFICATIONS

Application	Ft. Lbs. (N.m)
Radius Arm & Safety Strap-to-Body	40-45 (54-61)
Half Shaft Flange Nuts	49-55 (67-75)
Outer Suspension Arm Fulcrum Nut	95-105 (129-143)
Hub Carrier Assembly Nut	100-120 (136-163)
Stub Axle Nut	90-110 (122-150)
Caliper Bracket-to-Final Drive Housing .	60-69 (81-93)
Pinion Flange Nut	120-130 (163-177)
Differential Case Bolts	43-50 (58-68)
Bearing Cap Bolts	63-70 (86-96)