

Drive Axles

ISUZU P'UP & LUV

8-41

DESCRIPTION

Rear axle housing is banjo type with removable differential carrier and semi-floating axle shafts. Front axle has removable differential carrier and full-floating axle shafts.

Both differentials are hypoid type ring and pinion gears. The axle shafts are retained in housing by cone-type roller bearings and bearing retainers at axle housing outer ends.

AXLE RATIO & IDENTIFICATION

All models are equipped with 1 type of rear axle. The front axle on 4-WD models is similar to rear axle. Rear axle ratio on 2-WD vehicles with manual transmission is 3.42:1 for gasoline model, and 3.73:1 for diesel model.

The gear ratio on automatics and 4-WD vehicles front and rear is 4.10:1. Gear ratio is determined by dividing the number of ring gear teeth by the number of drive pinion gear teeth.

REMOVAL & INSTALLATION

AXLE SHAFTS & BEARINGS

NOTE: Front axle assembly must be removed prior to removal of axle shafts and bearings.

Removal (Front)

1) Disconnect propeller shaft at front differential. Raise front of vehicle on hoist until weight is removed from springs. Support frame on jack stands. Remove wheels and skid plate.

2) Completely loosen torsion bar by turning height control arm adjusting bolts. Remove strut bars. Remove stabilizer bar-to-lower control arm bolts and disconnect stabilizer.

3) Remove brake calipers from supports and hang on frame with wire. Disconnect ball joints at outer tie rods. Remove upper control arms from frame brackets by removing bolts from upper pivot shafts.

4) Tape shims packs together and mark for reinstallation for proper camber and caster adjustments. Remove lower control arm link ends, shock absorber-to-lower control arm bolts and lower control arms.

5) Shift transfer shift lever into "2H" position and set locking hub knob to "FREE" position. Remove locking hub assembly. Remove snap ring and shims from end of spindle.

6) Remove hub and rotor assembly along with upper link and front axle (both sides). Disconnect Pitman arm and idler arm. Remove steering linkage assembly.

NOTE: See Locking Hub article in this section for complete removal and installation procedures of locking hubs.

7) Support front axle assembly on jack and remove 4 axle case mounting bolts. Lower and remove front axle assembly. DO NOT damage Birfield or double offset joints.

8) Drain differential housing, remove 4 axle mounting bracket-to-axle housing bolts. Pull axle shafts from both sides of housing.

9) Remove axle shaft bearing from steering knuckle using a puller. Drive out bearing races with brass drift and replace races with press. Install new bearings.

Installation

1) Install axle shafts in housing and tighten 4 axle mounting bracket-to-axle housing bolts. Place front axle assembly on jack and position under vehicle frame.

2) Install axle assembly and tighten case mounting bracket bolts. Install Pitman arm to steering sector shaft and idler arm to pivot shaft. Tighten bolts.

3) Install hub and rotor assemblies with upper control arms to axle shaft ends. Install pivot shaft to frame bracket. Install camber and caster adjusting shims in original positions.

4) Refit shock absorbers. Connect lower control arms to frame brackets. Connect ball joints to knuckle arms and tighten castellated nuts.

5) Install strut bars and stabilizer bar ends. Tighten control arm adjusting bolts. Install disc brake caliper assemblies. Thoroughly lubricate locking hub body and lock washer. Install snap ring.

6) Push axle shaft with hand pressure and set clearance between locking hub body and snap ring to 0-.01" (0-.3 mm) using required shims. Install gasket and locking hub cover, aligning stopper rails during installation.

7) Install wheels and skid plate. Align propeller shaft index marks and install propeller shaft. Tighten all nuts and bolts to specifications. Fill front differential with lubricant. Bleed hydraulic brake system if required.

Fig. 1: Exploded View of Isuzu & LUV 4-WD Front Axle Assembly

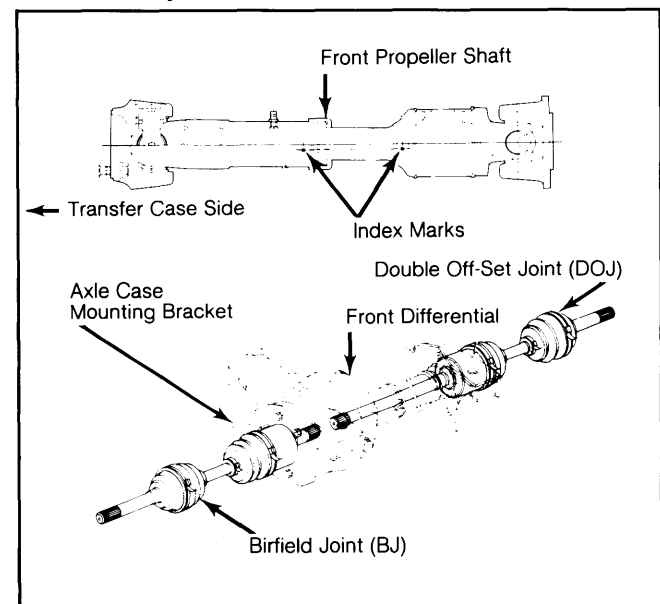

Removal (Rear)

1) Raise vehicle, remove wheel and tire assembly. Remove brake drum, brake shoes and disconnect parking brake inner cable. Disconnect brake line from wheel cylinder and cover end to prevent loss of fluid and entry of dirt.

2) From inboard side of brake backing plate, remove 4 nuts from the bearing holder through bolts. Pull axle shaft from housing.

Drive Axles

ISUZU P'UP & LUV (Cont.)

Fig. 2: Exploded View of Rear Axle Shaft Assembly

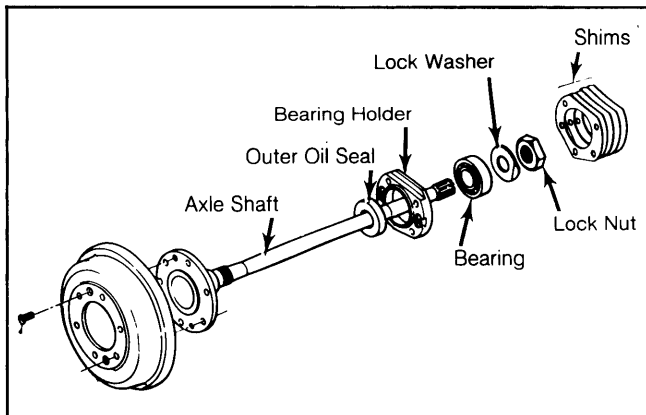

Bearing Replacement

1) To replace rear bearing, flatten locking tab of lock washer, mount axle shaft in a vise, clamping vise jaws around lock nut.

2) Using a puller positioned on lug bolts, turn axle shaft loose from lock nut, lock washer, bearing and holder and brake backing plate. Remove oil seal from outboard side of bearing holder. Drive off bearing outer race with a drift.

3) Install bearing outer race and grease seal into holder. Apply wheel bearing grease to bearing holder, rear axle tube and bearing inner race.

4) Insert 4 through bolts into backing plate. Install bearing holder to backing plate, making sure oil seal side of bearing holder is against backing plate.

5) Place backing plate assembly over axle shaft, position bearing over axle shaft and press into bearing holder. Install new lock washer with dished side away from bearing. Thread lock nut onto shaft.

6) Place lock nut between vise jaws and using tool used during disassembly, tighten lock nut securely. Bend over portion of lock washer opposite to locating tab to prevent lock nut from turning.

Installation

1) If both axle shafts were removed, insert a .079" (2 mm) shim between bearing holder and axle tube flange of first axle shaft to be installed. Insert shaft into axle tube and install and tighten bearing holder-to-flange bolts.

2) For the second axle shaft (or if only one shaft was removed), insert shaft without shims into axle tube until it comes into contact with thrust block in differential. Measure clearance between bearing holder and axle tube flange. See Fig. 4.

Fig. 3: Exploded View of Rear Axle Assembly

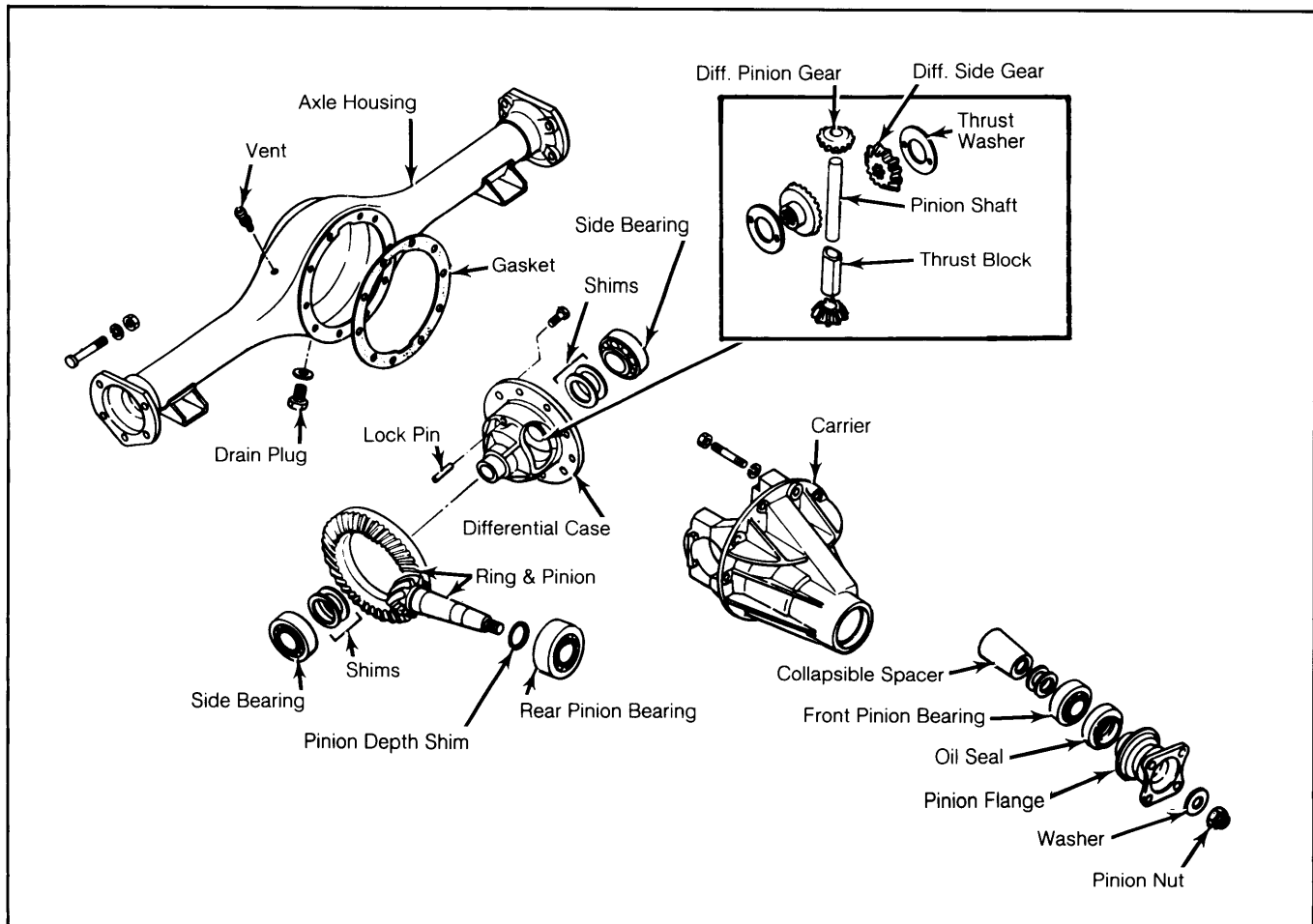

ISUZU P'UP & LUV (Cont.)

Fig. 4: Sectional View of Axle Shaft Bearing Assembly

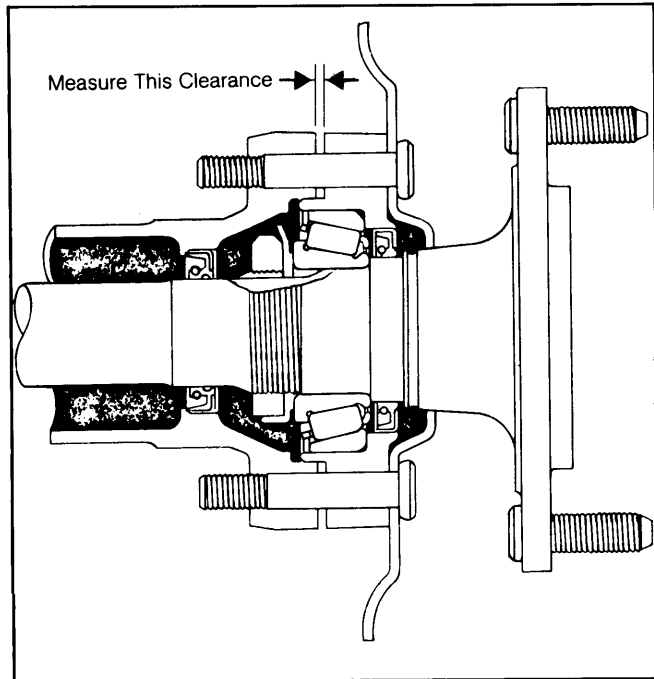

Measurement for rear axle shaft shim requirements.

3) Proper size shims for this location may be determined by adding .012" (.3 mm) to measurement just obtained. Select a shim or combination of shims, withdraw axle shaft and install shims between bearing holder and flange face.

4) Reinstall axle shaft and tighten 4 through bolts. Connect brake line to wheel cylinder. Install brake shoes, parking brake cable and brake drum. Install wheel and tire assembly, adjust brakes and bleed system.

DIFFERENTIAL CARRIER

NOTE: Front differential carrier is removed from front axle after axle has been removed from vehicle.

Removal (Rear)

1) Raise rear of vehicle and support with jack stands. Remove wheels and brake drums. Disconnect brake lines at wheel cylinders and plug. Disconnect parking brake cable brackets at rear spring location. Drain differential oil.

2) Remove 4 through bolts from each end flange and partially withdraw axle shafts from axle tubes. Disconnect propeller shaft from pinion flange and place out of way. Remove nuts attaching carrier to axle housing and remove carrier assembly.

Installation

To install, reverse removal procedure, making sure to refill axle with lubricant.

OVERHAUL

FRONT AXLE SHAFTS

NOTE: Axle shaft assembly is an integral unit and should be disassembled only to replace defective parts.

Fig. 5: Exploded View of Front Axle Shafts

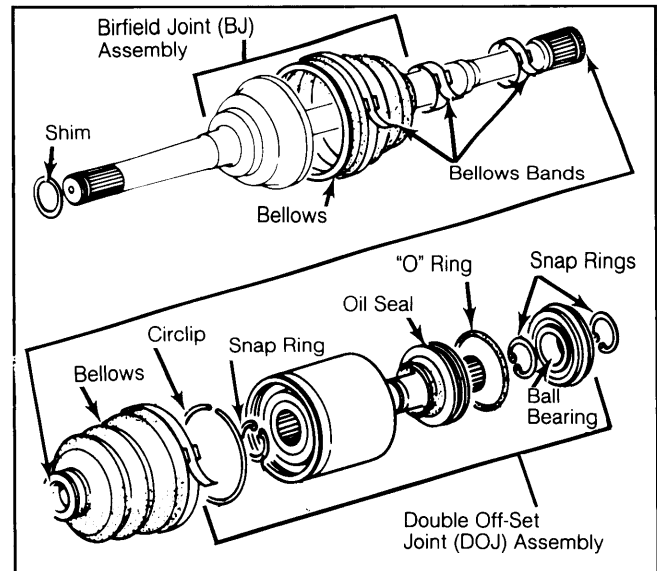

Birfield Joint (BJ) and Double Offset Joint (DOJ) shaft assemblies shown.

Disassembly

1) Remove front axle assembly and axle shafts as previously described. Using a screwdriver, lift hooked end of bellows band on larger diameter end of double offset joint (DOJ) and carefully remove bellows. Repeat procedure to remove band on smaller end. Discard bellows bands.

2) Slide bellows toward Birfield joint (BJ) side and pry off circlip. Hold DOJ case with hand and withdraw shaft. Remove grease. Remove 6 balls by prying out with screwdriver inserted against shaft.

3) Rotate bearing cage 1/2 pitch to align cage ball guide with ball retainer projection. Slide bearing cage toward bellows. Remove ball retainer. Remove bearing cage and bellow. See Fig. 6.

Fig. 6: Removing Bearing Cage and Retainer

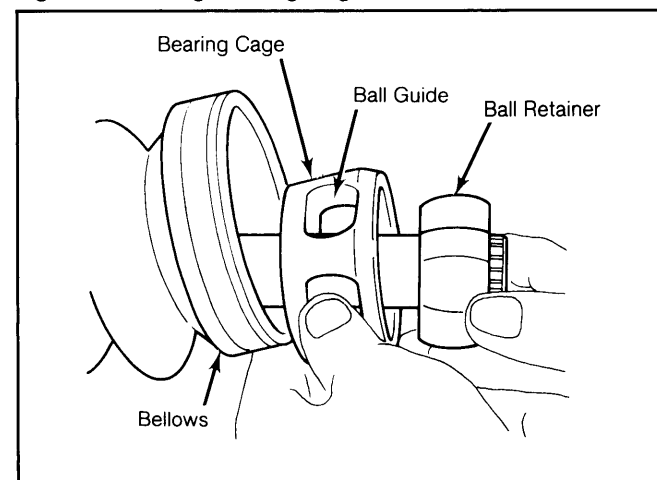

Bearing cage cannot be removed in reverse direction.

NOTE: BJ assembly is secured in position with axle shaft and cannot be disassembled. BJ assembly should be removed from DOJ assembly only to replace bellows.

Drive Axles

ISUZU P'UP & LUV (Cont.)

Inspection

1) Wipe all parts clean with a rag. Inspect the BJ and DOJ assemblies for play in normal direction of rotation. If variance exceeds $2\ 1/2^\circ$, replace entire axle shaft.

2) If axle shaft-to-case contact is found, check steering angle. If axle shaft-to-circlip or bottom case contact is found, check for transverse misalignment of front axle assembly.

Reassembly

1) Carefully install bellows to BJ assembly and fill half of the cavity with specified grease. Fill bearing cage with specified grease and seat bellows.

2) Install new bellows band. During installation of bellows, equalize air pressure on both sides to prevent premature wear due to collapse of bellows.

3) Working from DOJ assembly side, push bellows band and bellows onto shaft. Slide bearing cage onto shaft (smaller diameter side toward BJ end). Slide ball retainer onto shaft.

4) Secure ball retainer with snap ring. Align ball guide of bearing cage with ball retainer projection. Turn cage $1/2$ pitch. Press ball bearings into position with fingers.

5) Fill half the clearance of DOJ case with grease and position case over DOJ bearing assembly. Install circlip in groove with ends positioned at inner circumference, away from ball bearing groove. Pack DOJ assembly with grease and install bellows as previously described for BJ assembly.

DIFFERENTIAL ASSEMBLIES

NOTE: Overhaul procedures of front and rear differentials are similar.

Disassembly

1) Mark side bearing caps for reassembly reference. Remove nuts and bearing caps. Remove differential case assembly. Remove differential side bearings from case. Record thickness of each side bearing and shim pack and place with appropriate bearing race.

Fig. 7: Exploded View of Front Differential Assembly

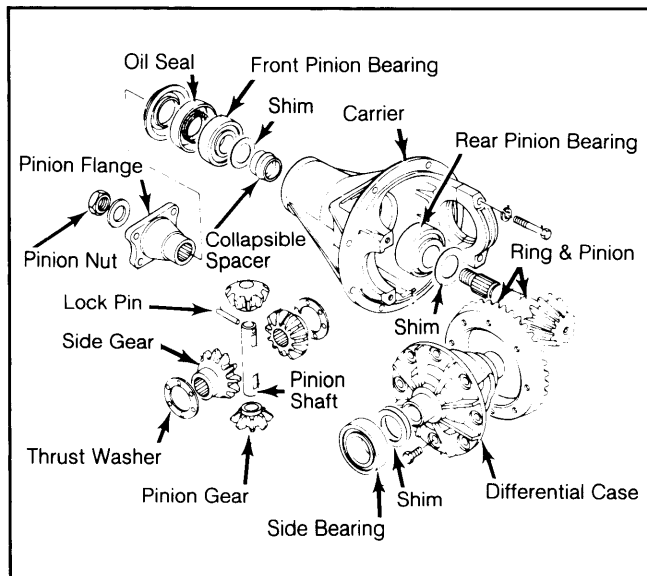

Keep right and left side bearing races with respective bearings.

2) Remove ring gear bolts and separate ring gear from case. Drive out pinion shaft lock pin using a long drift. Remove pinion shaft using a drift, then withdraw thrust block (rear differential), pinion gears, side gears and thrust washers.

Fig. 8: Removing Pinion Shaft Lock Pin

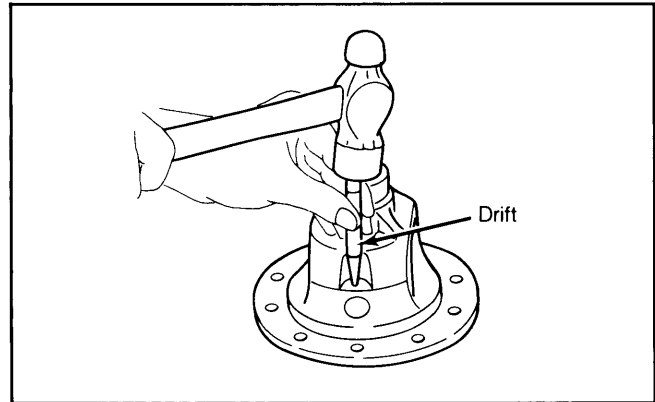

It may be necessary to remove caulking in lock pin using a 5 mm drill.

3) Remove pinion nut and pinion flange. Drive the pinion gear from carrier using a soft hammer or drift. Withdraw front pinion bearing and oil seal.

4) Using a drift, remove pinion bearing races from carrier. Mount pinion gear in a press and remove rear pinion bearing and depth shim from pinion gear.

Reassembly & Adjustment (Case Assembly)

1) Install side gears and thrust washers in case. Position thrust washers 180° apart, then roll gears into position making sure they are in alignment to allow installation of pinion shaft.

2) Place thrust block between pinion gears (rear differential only). Drive pinion shaft into position, making sure lock pin hole aligns with hole in case. Measure backlash between side gears and pinion gears; if greater than $.003"$ ($.08$ mm), install selective thrust washers to bring backlash within specifications.

3) Washers are available in thicknesses of $.041"$ (1.04 mm), $.045"$ (1.14 mm), $.049"$ (1.24 mm) and $.053"$ (1.35 mm).

NOTE: Increasing washer thickness decreases backlash; decreasing washer thickness increases backlash.

4) Install lock pin in pinion shaft and caulk end to prevent loosening. Install ring gear in position on case, apply Loctite to threads and tighten bolts in diagonal sequence to 80-87 ft. lbs. ($109-118$ N.m) on rear differential or to 44-58 lbs. ($60-80$ N.m) on front differential.

Reassembly & Adjustment (Drive Pinion Depth)

1) Install front and rear pinion bearing races into carrier bores. Lubricate pinion bearings and position in respective races. Install gauge plate, preload stud and pilot through front and rear bearing and tighten nut securely.

2) Rotate bearing to ensure proper seating. Tighten lock nut until 20 INCH lbs. (2.2 N.m) of torque are required to rotate new bearing, or 8-10 INCH lbs. ($1.0-1.2$ N.m) are required to rotate used bearings.

ISUZU P'UP & LUV (Cont.)

Fig. 9: Tool Arrangement for Measuring Drive Pinion Installed Height

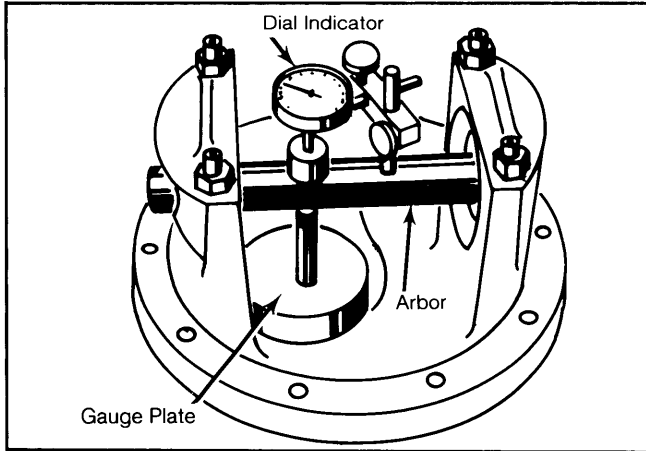

3) Place mounting discs on arbor tool and place assembly in position in side bearing bores. Install bearing caps snugly. Mount a dial indicator on arbor post and preload dial 1/2 revolution, then tighten indicator in this position.

4) Position indicator plunger on gauge plate, slowly swing across until highest reading is obtained, then "zero" indicator on highest reading of gauge plate.

5) Swing plunger off gauge plate and note indicator reading. Reading is the correct thickness of rear pinion depth shim for a nominal drive pinion.

NOTE: Front differential pinion shims are available in sizes ranging from .059-.077" (1.5-1.95 mm). Rear differential pinion shims are available in sizes ranging from .086-.101" (2.18-2.56 mm). A rear differential indicator reading of 0 (zero) or .001" (.03 mm) requires shims of .100" (2.54 mm) and .101" (2.56 mm) respectively.

Fig. 10: Pinion Depth Code Location on Pinion Head

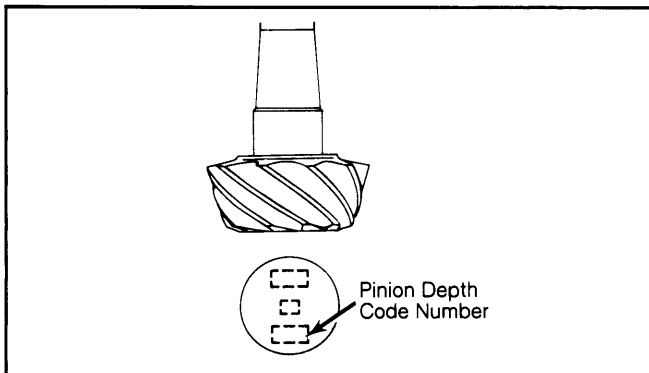

If pinion depth code is "0", the pinion is "nominal" and no dial indicator correction is required.

6) Examine head of drive pinion. Pinion depth code is stamped by chemical ink and is the lower of three numbers. A "+" (plus) number indicates need for greater mounting distance (decreased shim thickness).

7) A "-" (minus) number indicates need for smaller mounting distance (increased shim thickness). See appropriate chart to determine proper shim variation to compensate for plus or minus markings.

FRONT DIFFERENTIAL PINION DEPTH SHIMS

Pinion Code	Correction Required
+6	Subtract .0024" (.06 mm)
+4	Subtract .0016" (.04 mm)
+2	Subtract .0008" (.02 mm)
0	No Correction Required
-2	Add .0008" (.02 mm)
-4	Add .0016" (.04 mm)
-6	Add .0024" (.06 mm)

REAR DIFFERENTIAL PINION DEPTH SHIMS

Pinion Code	Correction Required
+10	Subtract .005" (.13 mm)
+8	Subtract .004" (.10 mm)
+6	Subtract .003" (.08 mm)
+4	Subtract .002" (.05 mm)
+2	Subtract .001" (.03 mm)
0	No Correction Required
-2	Add .001" (.03 mm)
-4	Add .002" (.05 mm)
-6	Add .003" (.08 mm)
-8	Add .004" (.10 mm)
-10	Add .005" (.13 mm)

8) Place selected shim on drive pinion and press rear bearing onto pinion. Remove gauging tools from carrier.

NOTE: DO NOT press on roller cage. Press only on bearing inner race.

Pinion Bearing Preload

1) Place drive pinion and collapsible spacer into carrier. Install front pinion bearing and oil seal. Mount pinion flange on drive pinion, apply lubricant to pinion threads and install pinion nut. Tighten rear differential nut to 85 ft. lbs. (116 N.m) and front differential nut to 108-145 ft. lbs. (150-200 N.m).

2) Rotate pinion to ensure bearings are seated. Wind a small amount of string (approximately 4-6 windings) around pinion flange. Using a pull scale, note reading required to rotate flange.

Fig. 11: Using Pull Scale to Measure Drive Pinion Bearing Preload

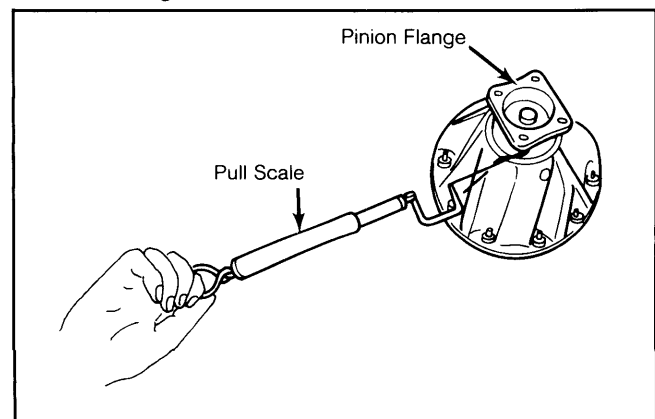

Drive Axles

ISUZU P'UP & LUV (Cont.)

3) Continue tightening nut in small increments until pull required to rotate flange is 17 lbs. (7.7 kg) for new bearings or 7-9 lbs. (3.2-4.1 kg) for used bearings.

CAUTION: Preload builds quickly. Nut should be tightened only in small increments and pull used after each small amount of tightening. If preload is exceeded, a new collapsible bearing spacer must be installed.

Backlash & Side Bearing Preload

1) If original side bearings, differential case, ring and pinion, and differential carrier are being reused, the original shims may be reinstalled in their respective positions.

2) If only new side bearings are being installed, measure new bearings with a micrometer and compare thickness with original bearings. If new bearing is thicker, SUBTRACT difference from shim pack. If new bearing is thinner, ADD difference to shim pack.

3) If new bearings, and/or differential case, ring and pinion, or differential carrier are being installed, new shims must be selected as follows. Install side bearings onto differential case, but do not install shims at this time.

4) Mount case into carrier bores. Move ring gear tightly against carrier on ring gear side (away from pinion), and hold in this position. Using a feeler gauge, measure clearance between bearing and differential carrier on side opposite ring gear. Record clearance.

5) Proper preload is established using the predetermined dimension of .002" (.05 mm). Therefore, ADD this dimension to clearance obtained in step 4) for proper preload. This will give required total thickness of both shim packs. Equally divide the total dimension for required shim pack thickness for each side.

6) Remove case from carrier, remove side bearings and install shim packs, then reinstall bearings. Install differential case into carrier, tapping carefully into place.

7) Install side bearing caps in original positions, install and tighten attaching bolts. Measure runout of ring gear. If runout exceeds .002" (.05 mm), correct by cleaning or replacing parts. See Fig. 12.

Fig. 12: Checking Ring Gear Backface Runout

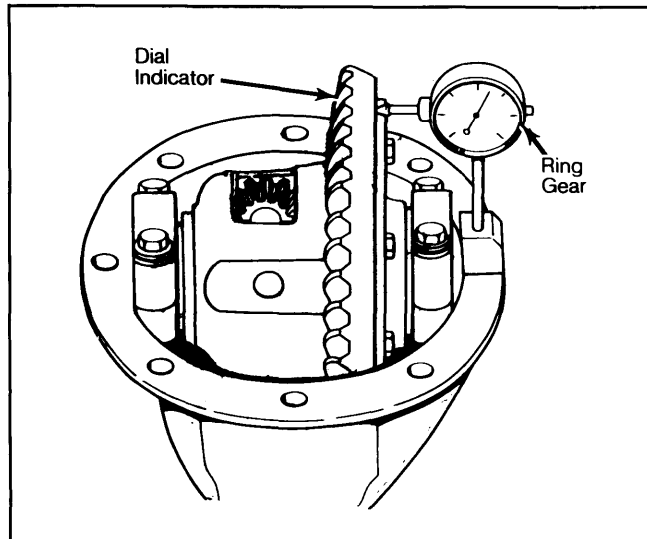

NOTE: Backlash changes approximately .002" (.05 mm) for each .003" (.08 mm) shim change.

8) Mount a dial indicator against ring gear teeth and measure backlash in three locations. Backlash should be .005-.007" (.13-.18 mm) on rear differential and .004-.006" (.10-.15 mm) on front differential.

9) If not within specifications, shims behind side bearings must be adjusted. To increase backlash, right side bearing shim must be increased and left side bearing decreased. To decrease backlash, right side bearing shim must be decreased and left side bearing increased.

NOTE: To maintain preload when backlash is adjusted, the total thickness of both shim packs must not be altered. Therefore, if it is necessary to increase one shim pack, the opposite shim pack must be decreased by the same amount.

Fig. 13: Checking Ring Gear-to-Drive Pinion Gear Backlash

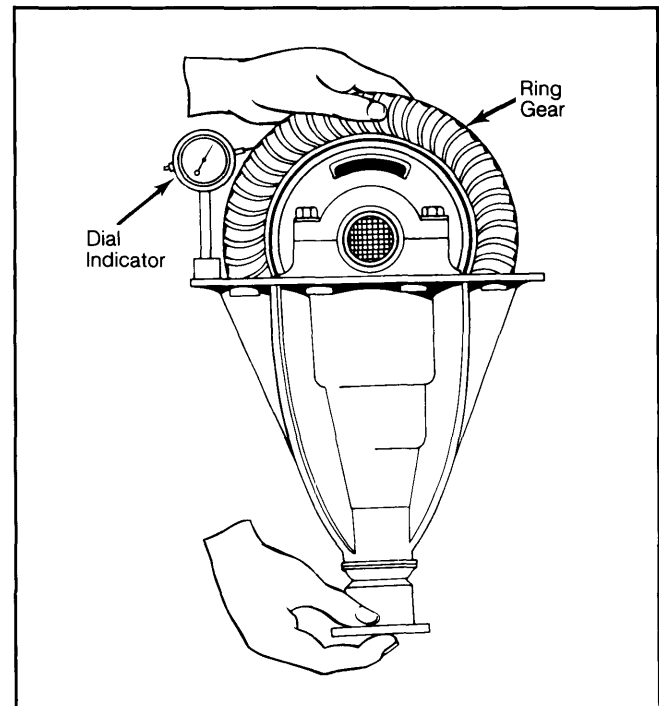

AXLE ASSEMBLY SPECIFICATIONS

Application	Specification
Pinion Bearing Preload ¹	
New Bearings	17 Lbs. (7.7 kg)
Used Bearings	7-9 Lbs. (3.2-4.1)
Side & Pinion Gear	
Backlash001-.003" (.025-.08 mm)
Side Bearing Preload	² .002" (.05 mm)
Ring Gear Backface Runout002" (.05 mm)
Ring Gear Backlash	
Front & Rear005-.007" (.13-.18 mm)

¹ — Measured with pull scale.

² — Add to side bearing "zero clearance" shim pack.

Drive Axles

ISUZU P'UP & LUV (Cont.)

TIGHTENING SPECIFICATIONS

Application	Ft. Lbs. (N.m)
Ball Joint Stud Nuts ¹	75 (102)
Ball Joint-to-Lower Arm	45 (61)
Control Arm Pivot-to-Frame	
Upper	76 (103)
Lower	130 (177)
Upper Control Arm Pivot Shaft Bushing	87 (118)
Lower Control Arm-to-Crossmember	94 (128)
Rotor-to-Hub	36 (49)
Strut Bar-to-Lower Arm	45 (61)
Strut Bar-to-Frame	
Lock Nut	50 (68)
Nut	15 (20)
Pitman Arm-to-Steering Shaft	160 (217)
Idler Arm-to-Pivot Shaft	87 (118)
Front Axle Mounting Bolts	15 (20)
Rear Propeller Shaft-to-Pinion Flange	18 (24)
Rear Axle Shaft Lock Nut	190 (258)
Rear Axle Bearing Through Bolt	52 (71)
Ring Gear-to-Case Bolts ²	
Front	44-58 (60-79)
Rear	85 (116)
Bearing Cap Nuts	
Front	50 (68)
Rear	75 (102)
Pinion Flange Nut ³	
Front	108-145 (147-197)
Rear	85 (116)
Carrier-to-Housing Bolts	18 (24)
Front Axle Shaft-to-Axle Case	44 (60)

¹ — Plus additional torque to align cotter pin hole.
NEVER back off to align cotter pin.

² — Threads coated with Loctite.

³ — Initial torque only.