

# Drive Axles

## COURIER

### DESCRIPTION

This axle assembly incorporates a removable carrier differential, having a hypoid type ring and pinion gear set. The pinion is retained in the carrier by a companion flange and nut. Semi-floating axles are secured in the housing by the axle shaft bearing retainers.

### AXLE RATIO & IDENTIFICATION

Only one type of axle assembly is used. Axle ratio can be determined by dividing the number of ring gear teeth by the number of pinion gear teeth. The 2.3L engine uses a 3.63:1 gear ratio, and the 2.0L engine uses a 3.31:1 gear ratio.

### REMOVAL & INSTALLATION

#### AXLE SHAFTS & BEARINGS

##### Removal

1) Raise and support vehicle. Remove tire and wheel. Remove brake drum and brake shoes. Disconnect and plug hydraulic line from wheel cylinder. Disconnect parking brake cable.

2) From inboard side of backing plate, remove 4 nuts from axle housing through bolts. Pull axle shaft, backing plate, bearing housing, and shims (if equipped) from axle housing using a puller. Remove oil seal from axle housing.

3) To replace rear bearings flatten locking tabs of lock washer. Loosen lock nut with spanner wrench. Remove lock nut and washer. Using a puller, remove bearing and housing assembly from axle shaft. Remove backing plate. Remove bearing and oil seal from housing.

##### Installation

1) Using seal driver, install new outer seal in bearing housing. Press or drive new bearing cup into retainer. Install brake backing plate, bearing housing, and bearing on axle shaft.

2) Place axle shaft on end in press. With bearing taper pointing in right direction, press bearing in place. Install lock washer and nut, using spanner to tighten nut.

3) Install axle shaft, and temporarily assemble 2 bolts through bearing housing and axle housing flange. Mount dial indicator to backing plate so axle end play can be measured.

4) If end play is not to specification, adjustment is made by using appropriate shims between axle housing

Fig. 2: Exploded View of Axle Assembly

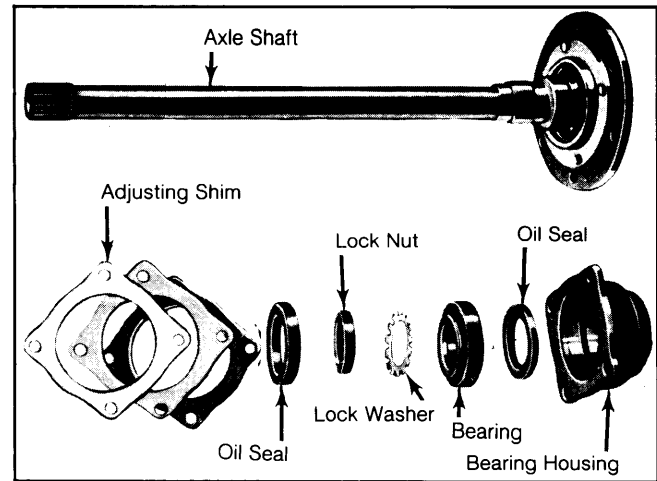
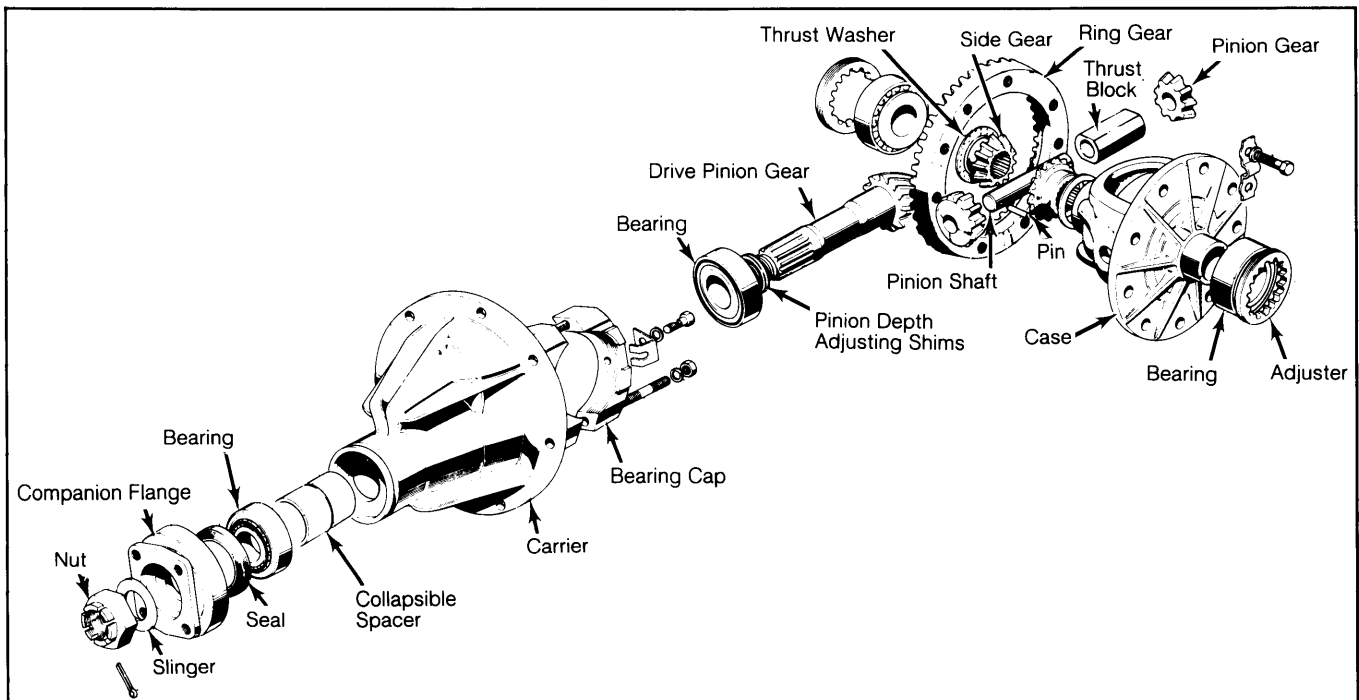

Fig. 1: Exploded View of Courier Differential Assembly



## COURIER (Cont.)

flange and bearing housing. After correct end play is obtained, install and tighten as necessary, all remaining components.

**NOTE:** If both axles have been removed, check end play of each shaft as it is installed.

### DIFFERENTIAL CARRIER

#### Removal

Raise and support vehicle. Drain lubricant from differential, and replace drain plug. Remove axle shafts as previously described. Mark drive shaft and companion flange at differential for reassembly reference. Remove drive shaft. Remove carrier-to-housing retaining nuts. Remove carrier from housing.

#### Installation

Reverse removal procedure noting the following. Use sealer between carrier and axle housing. Ensure drive shaft-to-companion flange reference marks are aligned.

## OVERHAUL

### DISASSEMBLY

1) Remove differential carrier as previously described. Mount carrier assembly in a holding fixture with ring gear facing upward.

2) Mount a dial indicator to carrier housing, and check ring gear runout for reference at time of reassembly. See Fig. 3. Also make a gear tooth contact pattern check. Refer to *Gear Tooth Patterns* article in this section.

**Fig. 3: Checking Ring Gear Backface Runout**

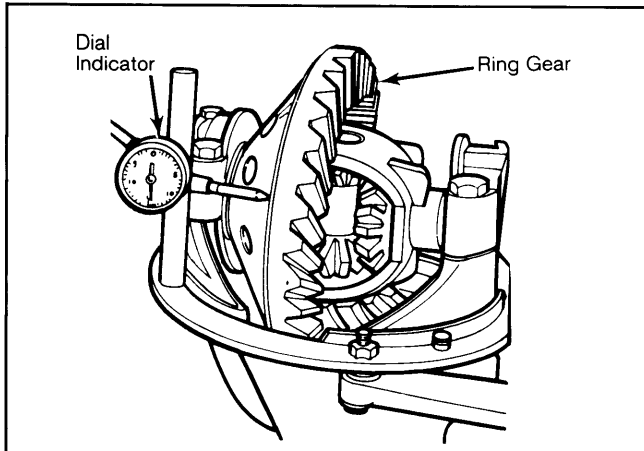

3) Punch mark differential bearing caps and adjusters for reassembly reference. Remove adjuster lock plates.

4) Loosen bearing cap nuts, and back off adjusters using spanner wrench. Remove nuts, bearing caps, and adjusters. Keep each bearing cap with its own adjuster.

**NOTE:** Left adjuster has left hand threads.

5) Lift out differential assembly keeping each bearing outer race with its own bearing. To remove differential bearings, use a puller. See Fig. 4. Remove

bolts and locks retaining ring gear to case. Remove ring gear.

6) Drive out differential pinion shaft lock pin, and remove pinion shaft and thrust block. See Fig. 4. Rotate pinion gears 90°, and remove them. Lift out differential side gears along with their thrust washers.

**Fig. 4: Removing Differential Bearings and Pinion Shaft Lock Pin**

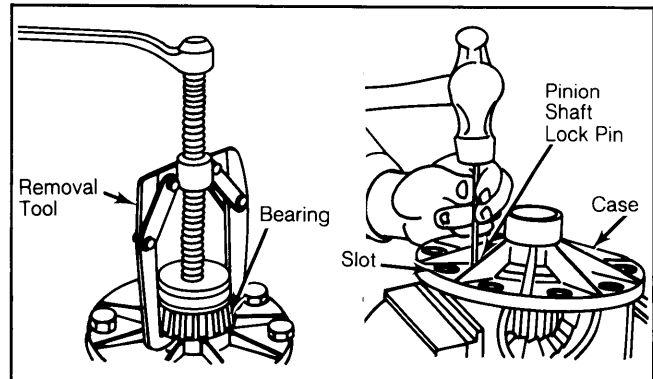

**CAUTION:** If required, use soft mallet to tap pinion gear from case, and guide pinion out to avoid damage to gear teeth.

7) Hold pinion gear companion flange. Remove nut and then flange. Remove drive pinion and rear bearing. Remove collapsible spacer, oil seal, and front bearing.

8) Remove pinion bearing races from carrier using a drift in slots provided. Remove bearing from pinion gear using puller. Remove pinion gear shim.

### REASSEMBLY & ADJUSTMENT

#### Case Assembly

1) If original ring and pinion gear set is being installed, use original shim between bearing and pinion head.

2) If a new gear set is being installed, determine the size of shim to use in the following manner. Drive pinions may be stamped either "A1, A2, A3" (positive amount) or "A-1, A-2, A-3" (negative amount).

3) Compare marks on tapered ends of old and new gears. Subtract the two numbers. A "+" number requires installation of THINNER shim than original. A "-" number requires installation of THICKER shim than original.

4) If gear is not marked, gear set is nominal size and NEW shim of original thickness in carrier should be used.

**NOTE:** Gear sets are stamped in increments of .0004" (.01 mm). To determine amount of variation, multiply stamped number times .0004" (.01 mm), and use the correct plus ("+") or minus ("-") sign. DO NOT use more than 4 shims.

5) Install pinion gear bearing races. See Fig. 5. Install selected shim on pinion gear. Install bearing on pinion using press. Install pinion gear and bearing in carrier followed by collapsible spacer, front bearing, oil seal and companion flange nut.

# Drive Axles

## COURIER (Cont.)

**Fig. 5: Installing Drive Pinion Bearing Races**

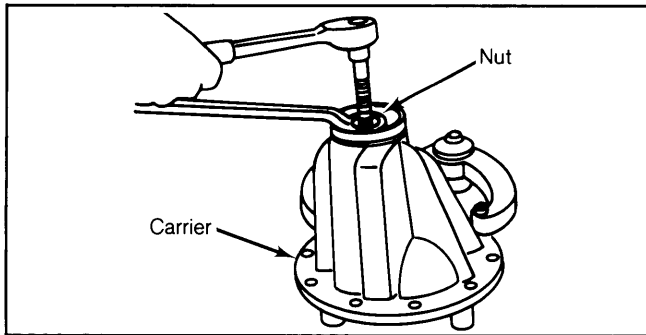

6) Using an INCH pound torque wrench on companion flange nut, rotate pinion gear, and note drag of oil seal. As nut is tightened, keep checking rotating torque with INCH pound torque wrench.

7) Preload is correct when nut is tightened to 145 ft. lbs. (197 N.m) minimum, and rotating torque is 11.3-15.6 INCH lbs. (1.28-1.76 N.m) plus oil seal drag.

**NOTE:** If preload is exceeded, install new collapsible spacer, and repeat procedure. Do not back-off nut to obtain preload.

### Differential Assembly

Reverse disassembly procedure noting the following checks and adjustments.

### Side-to-Pinion Gear Backlash

1) After installing side and pinion gears, insert pinion shaft, without thrust block, into its proper position. Check side-to-pinion gear backlash.

2) If backlash exceeds .008" (.20 mm), refer to table, and install appropriate side gear thrust washers to obtain the correct backlash. Remove pinion shaft, then reinstall it with the thrust block.

### SIDE GEAR THRUST WASHERS

I.D. Mark	Thickness In. (mm)
0 .....	.079 (2.0)
1 .....	.083 (2.1)
2 .....	.087 (2.2)

### Ring-to-Drive Pinion Gear Backlash

1) After differential is completely assembled and installed in carrier, snug bearing cap nuts. Turn adjusters, using spanner, until bearings are properly

**Fig. 6: Checking Ring-to-Pinion Gear Backlash**

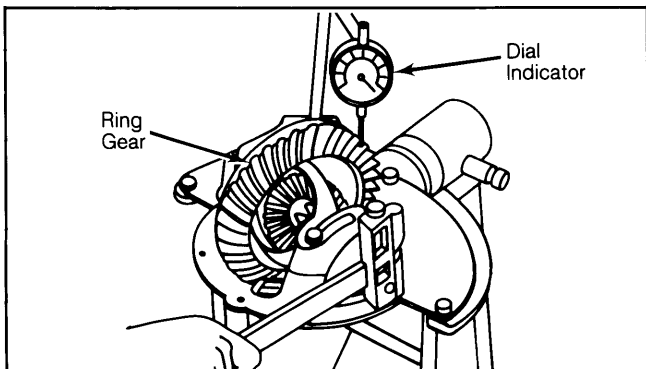

seated and end play is eliminated with a slight amount of ring-to-drive pinion gear backlash.

2) Slightly tighten one bearing cap nut on each side. Mount dial indicator to carrier flange with indicator plunger set at a right angle to ring gear teeth. Check ring-to-drive pinion gear backlash at four or five points around ring gear.

3) Turn both adjusters equally to obtain specified backlash. See Fig. 6. Proceed by setting differential bearing preload.

### Differential Bearing Preload

Taking care not to disturb ring-to-pinion gear backlash, set preload using a dial indicator. See Fig. 7. After setting preload, tighten bearing cap nuts, and complete assembly procedure.

**Fig. 7: Checking Differential Bearing Preload**

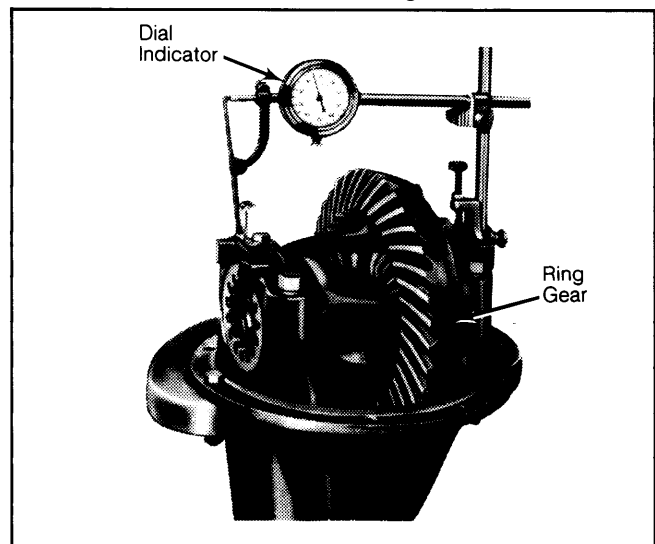

### AXLE ASSEMBLY SPECIFICATIONS

Application	Specification In. (mm)
Axle Shaft	
End Play <sup>1</sup> .....	.002-.004 (.05-.1)
Ring-to-Pinion Gear	
Backlash .....	.0075-.0083 (.19-.21)
Ring Gear Backface	
Runout (Max.) .....	.003 (.08)
Differential Bearing	
Preload .....	.0045 (.11)

<sup>1</sup> — If both shafts were removed, end play of first shaft installed should be .026-.033 (.65-.82).

### TIGHTENING SPECIFICATIONS

Application	Ft. Lbs. (N.m)
Differential Bearing Cap Nuts .....	40-49 (55-67)
Carrier-to-Axle Housing Nuts .....	11-17 (16-23)
Axle Shaft Bearing Retainer Bolts .....	12-16 (16-22)
Ring Gear-to-Case Bolts .....	53-60 (71-81)
Companion Flange Nut .....	145-250 (197-340)