

# Clutches

## SAAB 900 & 900 TURBO

### DESCRIPTION

Clutch is dry, single plate, diaphragm spring type. Primary components are: Disc, pressure plate assembly, and release bearing. Clutch operation is hydraulic. Slave cylinder is located inside clutch cover around input shaft. Slave cylinder acts directly on release bearing. Clutch adjustment is automatic.

### REMOVAL & INSTALLATION

#### CLUTCH ASSEMBLY

##### Removal

1) Remove the clutch cover housing. Disengage clutch and fit spacer ring 83 90 023 between diaphragm spring fingers and pressure plate cover. Spacer ring will keep clutch disengaged while removing components.

2) Unhook the spring clip and remove the cover located in front of the clutch input shaft. Remove the clutch input shaft plastic propeller.

3) Install an 8 mm bolt in the end of the clutch input shaft. Pry out the shaft with tool No. 83 93 175.

4) Remove the three slave cylinder retaining bolts. Remove the pressure plate bolts. Simultaneously lift out the clutch assembly, slave cylinder and release bearing.

**NOTE:** Make sure diaphragm spring does not damage slave cylinder sleeve during removal or installation.

Fig. 1: Lifting Out Clutch Assembly

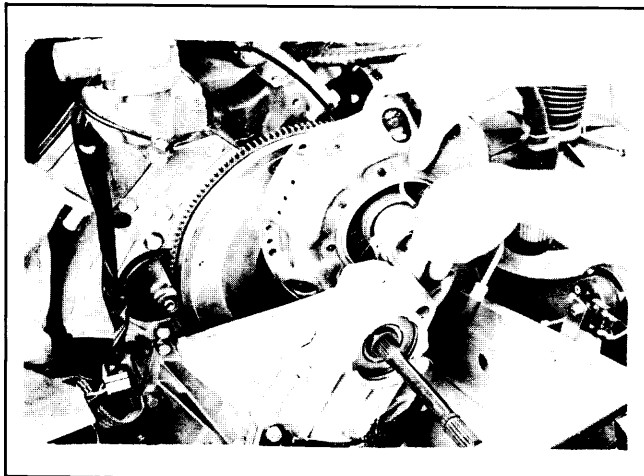

Illustration shows relationship of clutch assembly to surrounding engine components.

##### Inspection

1) Check the surface of the flywheel for burns, cracks or scoring. Resurface if necessary. The height of bolt heads on 5 speed transmissions are lower than 4 speed bolts. If replacing, use same type bolts.

2) Inspect the pressure plate surface for cracks or scoring. Measure pressure plate warpage with a straightedge and feeler gauge.

3) A maximum gap of .0012" (.03 mm) is allowable at the inner edge of the pressure plate friction surface. No clearance is allowed at the outer edge of the surface. Make checks at several points.

##### Installation

1) Before beginning clutch installation make sure input shaft seal is in good condition. Seal is located in primary gear case and forms a direct bond with sealing surface of input shaft.

2) Reassemble clutch assembly and loosely install two pressure plate retaining bolts. Hardened side of release bearing faces diaphragm spring.

3) Coat clutch input shaft splines with molybdenum grease and install. Knock the input shaft into position. Coat slave cylinder bolts with Loctite and install slave cylinder.

**NOTE:** DO NOT depress clutch pedal farther than necessary. Seal lip may be pressed too far, causing a hydraulic leak and seal damage.

4) Torque pressure plate bolts. Depress clutch pedal and remove spacer. With pedal depressed, install sliding lock ring toward slave cylinder. Complete installation by reversing removal procedure.

#### CLUTCH MASTER CYLINDER

##### Removal & Installation

1) Remove hydraulic line at rear of cylinder. From under instrument panel in vehicle, remove access cover on left side. Remove push rod pin at clutch pedal. Remove master cylinder retaining nuts from firewall.

2) From engine compartment, remove fluid supply line from top of cylinder and position so fluid does not leak. Remove master cylinder. To install, reverse removal procedure and bleed system.

#### CLUTCH SLAVE CYLINDER

Slave cylinder removal is accomplished during clutch assembly removal. See Clutch Assembly Removal in this article.

### OVERHAUL

#### CLUTCH MASTER CYLINDER

##### Disassembly

1) Pull back sealing bellows and remove retaining ring. Remove push rod and washer. Remove piston, convex washer, piston seal, and spring.

2) Inspect cylinder bore for wear or damage. Replace complete assembly if cylinder is worn or damaged. Replace seal if worn or swollen.

Fig. 3: Exploded View of Clutch Master Cylinder

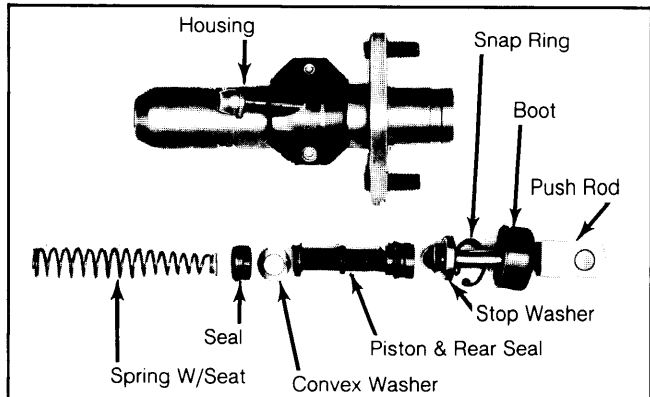

## SAAB 900 & 900 TURBO (Cont.)

### Reassembly

Install return spring and spring retainer. Lubricate piston and seals with clean brake fluid. Install seals, convex washer and piston. Install push rod followed by washer and retaining ring. Install sealing bellows. See Fig. 4.

**Fig. 4: Installing Convex Washer in Master Cylinder**

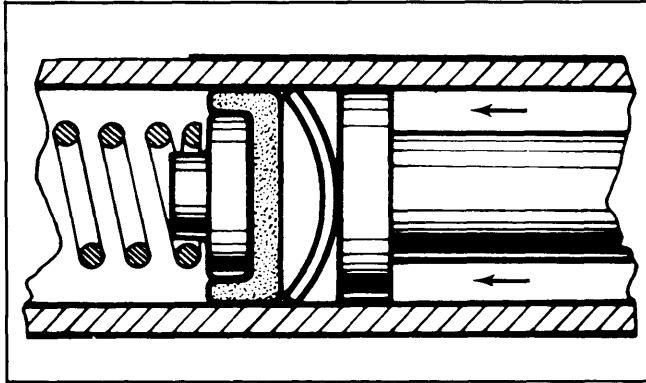

Convex side must face master cylinder piston.

### CLUTCH SLAVE CYLINDER

#### Disassembly

Remove clutch release bearing from slave cylinder. Set slave cylinder with release bearing end facing up. Press cylinder sleeve out. Remove "O" ring from sleeve. Remove piston and lip seal.

#### Reassembly

1) Before beginning reassembly, lightly coat lip seal and piston (not "O" ring) with Caster Rubber Grease (or equivalent).

2) Fit "O" ring to sleeve flange. Slide seal lip on sleeve. Coat sleeve flange with brake fluid. Insert sleeve into cylinder. Push seal lip part way into cylinder.

3) Guide sleeve and cylinder together by pushing on piston until lock rings and "O" ring are fitted. Place slave cylinder on support and seat sleeve into cylinder. Fit release bearing to piston.

**Fig. 5: Exploded View of Clutch Slave Cylinder**

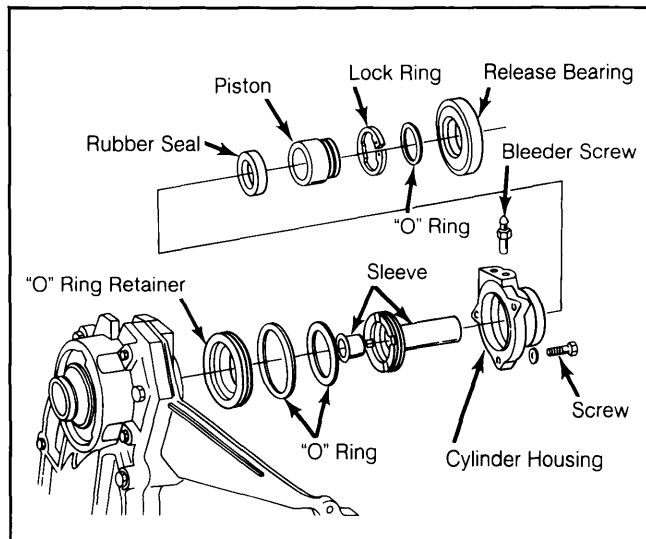

### INSPECTION

#### CLUTCH DISC WEAR

##### Early Design

1) Remove the rectangular inspection plate on the top of the clutch cover. Slowly disengage the clutch and then release the pedal. Release bearing should be in contact with pressure plate fingers.

2) Through the inspection hole, check that the sliding lock ring on the piston in the slave cylinder is in contact with the cylinder walls.

3) The minimum distance between the sliding lock ring and the lock ring behind the release bearing must be .04" (1 mm).

##### Late Design

Remove cover plate in the clutch housing cover and look through the inspection hole. Measure the distance between the plastic sleeve front edge and front edge of the machined surface of the slave cylinder housing. Clutch disc is worn if distance is less than .08" (2 mm).