

# Clutches

## DATSUN/NISSAN — EXCEPT 310, SENTRA & STANZA

### DESCRIPTION

Clutch is dry, single disc type. All models use a diaphragm spring type pressure plate and pre-lubricated clutch release bearing. Clutch is operated by a firewall mounted master cylinder and a clutch housing mounted slave cylinder.

All models except 210 have a non-adjustable slave cylinder assembly. On 210 models, a threaded push rod and lock nut enable adjustment at the slave cylinder.

**Fig. 1: Typical Datsun/Nissan Hydraulic Clutch System**

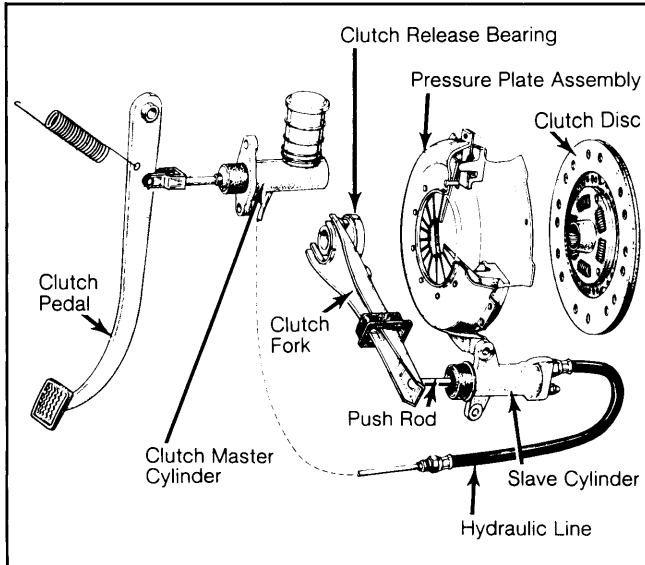

*Different models may vary slightly.*

### REMOVAL & INSTALLATION

#### CLUTCH ASSEMBLY

**NOTE:** Removal procedure is general. Some steps may not apply to all models.

#### Removal

1) Disconnect negative battery cable and accelerator linkage. Remove console box and place transmission shift lever in neutral. Remove control lever boots, snap ring (nut, if required), and shift lever pin. Remove shift control lever.

2) Raise and support vehicle on safety stands and disconnect exhaust pipe from manifold. If required, remove bolts mounting exhaust pipe bracket to extension housing or rear engine crossmember. Remove exhaust pipe insulator (if equipped) and lay over exhaust pipe.

3) Disconnect back-up light, neutral, overdrive and transmission controlled spark connectors (if equipped). Disconnect speedometer cable on all except 4-WD models.

4) Index mark all propeller shafts and companion flanges prior to removal. On 4-WD models, remove primary and front propeller shafts, and front differential carrier crossmember.

5) Remove slave cylinder. On all except 4-WD, separate center support bearing (if equipped) from crossmember and remove propeller shaft. On all models,

plug rear extension of transmission after removing propeller shaft to prevent loss of transmission fluid.

6) Support engine on jack. Support transmission with transmission jack, then loosen rear engine mount attaching bolt and remove rear engine mounting bracket. Remove starter.

7) Remove engine-to-transmission bolts. With engine supported and transmission mounted on transmission jack, slide transmission rearward and remove from vehicle.

8) Install clutch alignment tool and loosen pressure plate bolts one turn at a time. Use a criss-cross pattern to loosen bolts until spring pressure is relieved. Remove pressure plate and clutch disc.

**NOTE:** Be sure to keep disc facing flywheel and pressure plate clean, dry and free of grease and oil.

#### Inspection

1) With disc installed on transmission input shaft spline, the backlash measured at the outside edge of disc must be less than .016" (.4 mm). Replace disc and/or input shaft if backlash is excessive.

2) Check clutch for runout at the specified radius from the centerline of the disc hub. See Clutch Disc Runout Specifications table. Replace if runout exceeds limit.

#### CLUTCH DISC RUNOUT SPECIFICATIONS

Application	Radius In. (mm)	Runout In. (mm)
200SX	4.25 (108)	.20 (.5)
210	3.35 (85)	.20 (.5)
Maxima	4.23 (107.5)	.20 (.5)
280ZX		
Non-Turbo	4.23 (107.5)	.20 (.5)
Turbo	4.53 (115)	.20 (.5)
PickUp	4.25 (108)	.20 (.5)

3) Check face of disc for wear, grease or oil. The minimum distance from the rivet head to face of disc is .012" (.3 mm).

#### Installation

1) Lubricate clutch disc splines with small amount of multipurpose grease. Slip clutch assembly over guide dowels. Use clutch aligning tool to center disc and pressure plate.

2) Torque bolts one turn at a time in a criss-cross pattern. Adjust linkage and pedal. Check and refill transmission lubricant. Bleed clutch hydraulic system and replenish fluid.

#### CLUTCH MASTER CYLINDER

##### Removal & Installation

1) Disconnect master cylinder push rod at clevis. Disconnect hydraulic line to slave cylinder. Remove cylinder attaching bolts and remove cylinder. Remove master cylinder dust cover if equipped.

2) On 280ZX models only, remove windshield washer tank and clear fuel injection resistor before removing master cylinder. To install, reverse removal procedure, bleed hydraulic system and adjust pedal height and free play.

## DATSUN/NISSAN — EXCEPT 310, SENTRA & STANZA (Cont.)

### CLUTCH DAMPER

#### Diesel Engines Only

Remove hydraulic lines from clutch damper. Remove clutch damper from bracket. To install, reverse removal procedure, bleed hydraulic system and adjust pedal height and free play.

### CLUTCH SLAVE CYLINDER

#### Removal & Installation

Remove clutch fork return spring (if equipped). Disconnect hydraulic line from cylinder, remove bolts attaching cylinder to clutch housing, and remove slave cylinder. To install, reverse removal procedure, bleed hydraulic system and adjust pedal height and free play.

### CLUTCH RELEASE BEARING & LEVER

#### Removal

With transmission removed from vehicle, remove dust boot from clutch housing. Disconnect release lever retaining spring or return spring, as required, and retaining clips holding release bearing to lever. Remove bearing and lever through front of clutch housing. Remove bearing from collar using a puller.

#### Installation

To install, reverse removal procedure and note the following: Apply multi-purpose grease to inside surface of bearing collar, release bearing contact points, release bearing, ball pin in clutch housing, and ball contact points on release lever.

## OVERHAUL

**NOTE:** Master cylinders and slave cylinders may be supplied by more than one manufacturer. Parts are not interchangeable. Ensure that overhaul kit matches cylinder.

### CLUTCH MASTER CYLINDER

1) With master cylinder removed, remove filler cap and drain fluid. Remove dust cover and stopper ring.

Fig. 2: Exploded View of Clutch Master Cylinder

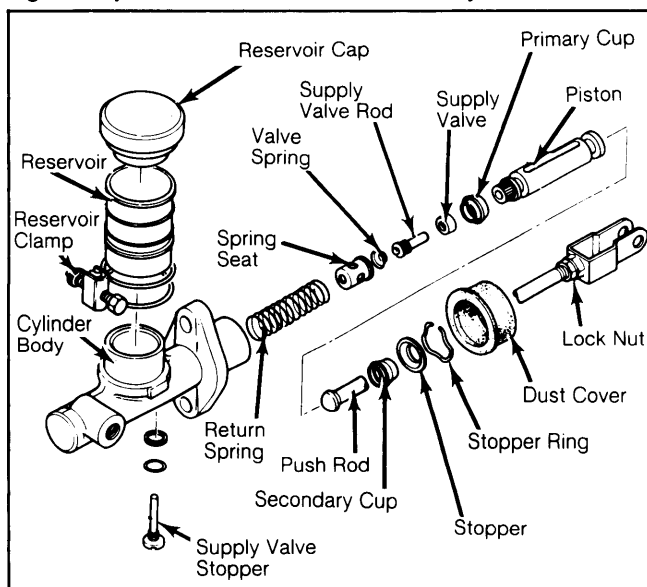

Remove push rod and stopper. Remove supply valve stopper, then take out piston, spring seat and return spring.

2) Clean all parts in clean brake fluid and inspect for wear or damage. If cylinder-to-piston clearance exceeds .006" (.15 mm), replace defective part.

3) Replace piston cup and dust cover during overhaul. To assemble, coat all parts with brake fluid and reverse disassembly procedure. Bleed hydraulic system and adjust pedal height.

### CLUTCH SLAVE CYLINDER

1) With slave cylinder removed, remove push rod and dust cover. Remove piston, piston cup and piston spring as an assembly. Remove bleeder screw.

Fig. 3: Exploded View of Clutch Slave Cylinder Assembly

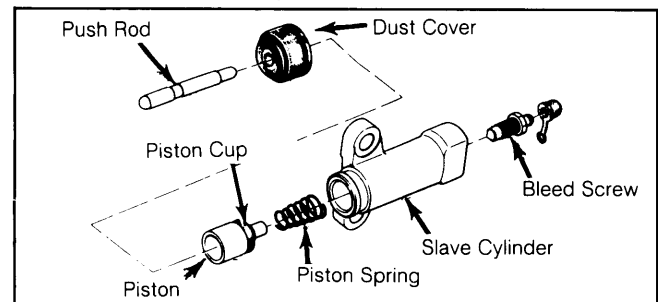

All models except 210.

2) Clean all parts in clean brake fluid and inspect for wear or damage. If cylinder-to-piston clearance exceeds .006" (.15 mm), replace defective part. Replace piston cup and dust cover during overhaul.

3) To assemble, coat all parts with brake fluid and reverse disassembly procedure. Ensure piston cup is installed properly and bleed hydraulic system.

Fig. 4: Exploded View of 210 Clutch Slave Cylinder

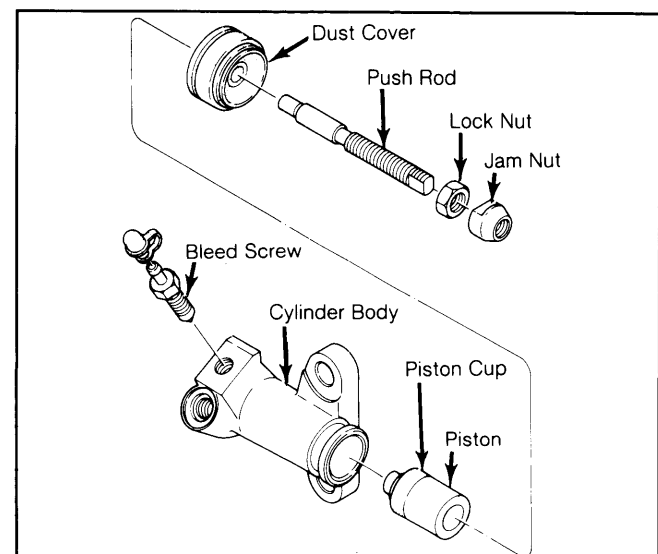

### CLUTCH DAMPER

#### Maxima & Pickup Diesel Engines Only

1) Remove four cover attaching screws. Do not let oil touch damper rubber. Remove damper rubber,

# Clutches

## DATSUN/NISSAN — EXCEPT 310, SENTRA & STANZA (Cont.)

piston and piston cup. Clean all parts in brake fluid. Check cylinder bore and piston for wear or damage.

2) If cylinder-to-piston clearance exceeds .006" (.15 mm), replace defective parts. Always replace piston cup during overhaul. Check damper rubber for cracks, deformation and elasticity and replace if necessary.

3) To assemble, lubricate all parts in brake fluid and reverse disassembly procedure. Bleed hydraulic system and adjust pedal height and free play.

### PEDAL HEIGHT SPECIFICATIONS

Application	In. (mm)
200SX .....	6.61-6.85 (168-174)
210 .....	5.63-5.87 (143-149)
280ZX .....	7.99 (203)
Maxima .....	7.17-7.32 (182-186)
Pickup	
Gasoline .....	6.73-6.97 (171-177)
Diesel .....	7.05-7.28 (179-185)

## ADJUSTMENT

### PEDAL HEIGHT & FREE PLAY

1) Adjust pedal height on all models except 280ZX and Pickup by turning pedal stopper adjusting nut. Pickup models are adjusted by turning clutch switch adjusting nut.

Fig. 5: Adjusting Clutch Pedal Height & Free Play

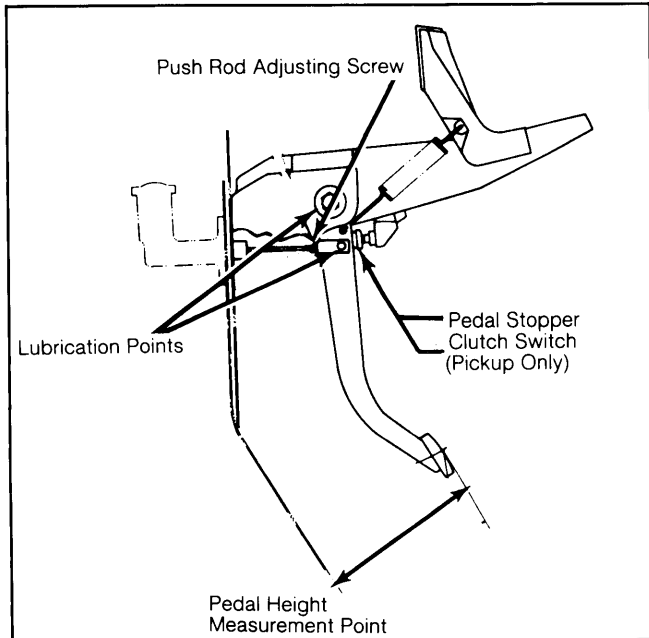

Figure applies to all models except 280ZX.

2) Adjustment on 280ZX models is made by first setting adjusting rod length to 6.10" (155 mm). See Fig. 6. Then adjust master cylinder push rod so that pedal height is 8.11" (206 mm).

3) Turn pedal stopper or clutch switch until pedal height is down to 7.99" (203 mm). See Fig. 7. On all models, free play is adjusted to .04-.20" (1-5 mm) by turning master cylinder push rod in or out.

Fig. 6: Adjusting Clutch Pedal Rod

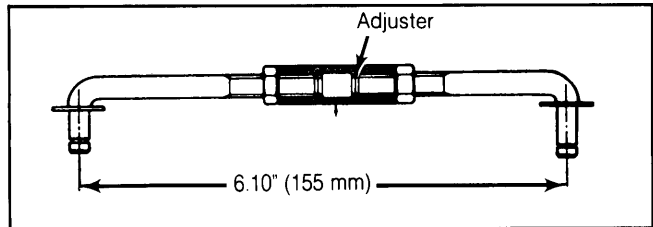

Illustration applies to the 280ZX model only.

### CLUTCH FORK FREE PLAY

#### 210

Loosen lock nut and push rod nut and turn push rod until release bearing lightly touches clutch diaphragm spring. Turn rod back (in opposite direction) about 1 1/4 turn and tighten lock nut.

Fig. 7: Adjusting Pedal Height & Free Play

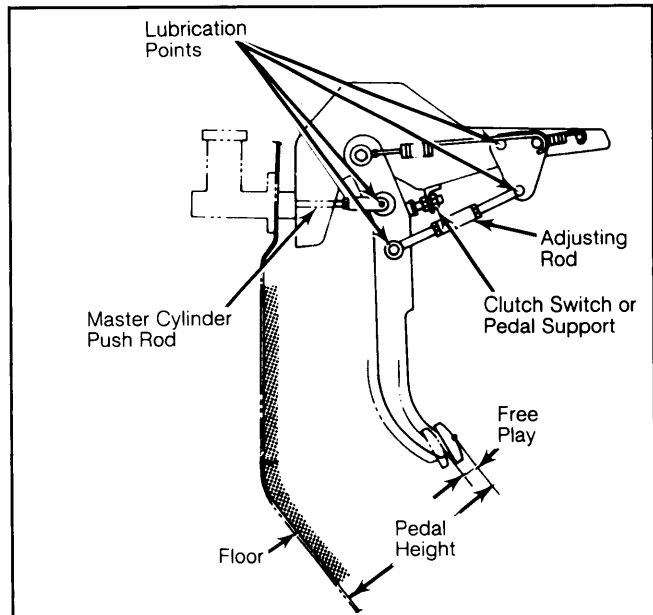

Illustration applies to 280ZX model only.

This provides about .04-.08" (1-2 mm) clearance between push nut and lever. Work clutch pedal several times and recheck pedal play.

Fig. 8: Adjusting Clutch Fork Free Play

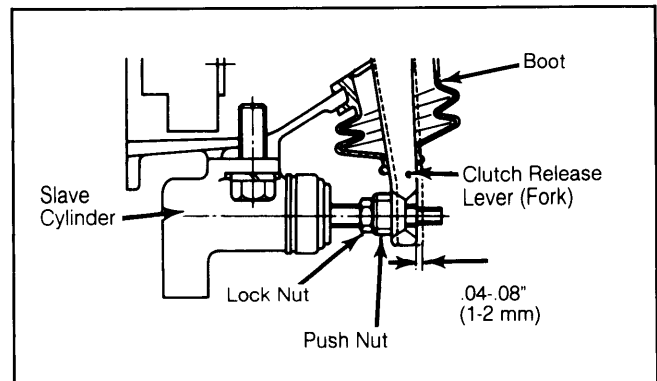

Illustration applies to Datsun/Nissan 210 model only.

## DATSUN/NISSAN — EXCEPT 310, SENTRA & STANZA (Cont.)

### HYDRAULIC SYSTEM BLEEDING

**NOTE:** On all diesel engine models equipped with clutch damper, bleed clutch damper then slave cylinder.

Fill reservoir with brake fluid. Fit bleeder hose to bleeder screw. Place opposite end of hose into a clear container partially filled with brake fluid. Pump clutch pedal two or three times and hold to floor.

Break bleeder screw loose and allow air to vent. Close bleeder screw and allow pedal to return. Repeat procedure until no air bubbles are present in discharged fluid.

### TIGHTENING SPECIFICATIONS

<b>Application</b>	<b>Ft. Lbs. (N.m)</b>
Clutch-to-Flywheel Bolts .....	12-15 (16-21)
Engine-to-Transmission Bolts	
210 .....	12-16 (16-22)
All Others .....	32-43 (43-58)