

BMW

320i, 528e, 633CSi, 733i

DESCRIPTION

Clutch is dry single disc type using a diaphragm spring pressure plate. System is hydraulically operated by a clutch housing mounted slave cylinder and a firewall mounted master cylinder. Slave cylinder automatically adjusts for disc wear.

Fig. 1: Typical BMW Clutch Assembly

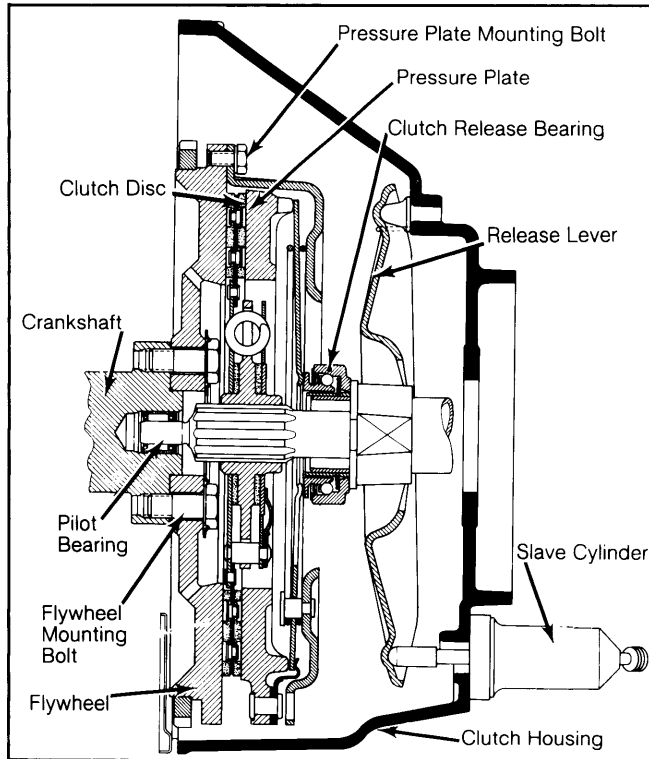

REMOVAL & INSTALLATION

CLUTCH ASSEMBLY

Removal

1) On 320i models only, engage reverse gear. On all models, detach selector rod from gearshift lever. From inside vehicle, left shift lever dust boot and remove circlip holding lever in place. Remove shift lever. Detach any exhaust system components which may interfere with transmission removal.

2) Fit clamp tool (26 1 011) to propeller shaft coupling and remove bolts holding coupling to transmission shaft coupler. Remove heat shield and detach bearing center bracket. On 733i, remove web under propeller shaft tunnel. On all models, remove center support bearing and bend propeller shaft so it can be removed from front coupling and placed out of way.

3) Support transmission and detach cross-member from body. Disconnect speedometer cable and housing from transmission. Detach clutch slave cylinder from clutch housing, leaving hydraulic line attached. Disconnect any electrical connections from transmission and remove transmission mounting nuts. Remove transmission.

4) Remove flywheel inspection cover and bolts securing clutch housing to engine. Loosen pressure plate bolts one turn at a time and remove clutch assembly.

Installation

1) Using an alignment tool (21-2-100 or equivalent), install clutch disc and pressure plate. Tighten mounting bolts 1 turn at a time to 16-17 ft. lbs. (22-23 N.m).

2) On all models except 320i, install clutch housing. On all models, apply a light film of grease on all surfaces subject to wear.

3) Install slave cylinder so that bleeder screw is at bottom. Install propeller shaft and preload center bearing by moving bracket .078" (2.0 mm) forward in slots provided. Install and tighten NEW nuts to 72 ft. lbs. (98 N.m) while holding bolts in front of propeller shaft coupling.

RELEASE BEARING & LEVER

NOTE: Coat all points subject to wear with Molykote 2 (or equivalent) prior to installation.

Removal & Installation

With transmission and clutch housing removed from engine, remove spring from pivot end of release arm and slide off arm and bearing assembly.

Separate release bearing from arm and measure for overall length of 1.93-1.97" (49.1-49.9 mm). Replace as required. To install, pack lubricating groove with lubricant and reverse removal procedure.

CLUTCH MASTER CYLINDER

Removal

1) Remove trim under left side of instrument panel. On 320i models, remove accelerator cable. Remove bolt attaching master cylinder push rod to clutch pedal.

2) Siphon off brake fluid from reservoir until level is below clutch master cylinder supply port and detach hydraulic lines from clutch master cylinder. On 733i models only, remove windshield washer tank. On all models, remove mounting bolts at firewall and remove master cylinder from vehicle.

Installation

To install, reverse removal procedures and bleed hydraulic system. On 633CSi and 733i, ensure that pedal over-center spring is engaged in pedal guide before attaching push rod.

CLUTCH SLAVE CYLINDER

Removal & Installation

Siphon fluid from reservoir and detach slave cylinder from housing. Disconnect hydraulic line and remove cylinder. To install, reverse removal procedure, ensuring that cylinder is mounted with bleeder screw at bottom. Fill reservoir and bleed system.

OVERHAUL

CLUTCH MASTER CYLINDER

Slide dust boot off and remove circlip holding push rod. Remove piston assembly and clean master cylinder and parts with alcohol. Inspect cylinder bore for corrosion or scoring; replace if required. Lubricate internal parts with brake fluid and reassemble. Adjust push rod length to approximately 5.5" (140 mm). See Fig. 2.

Clutches

BMW (Cont.)

NOTE: Coat all pivot points on clutch pedal assembly with Molykote 2 (or equivalent) prior to assembly.

Fig. 2: Sectional View of Clutch Master Cylinder

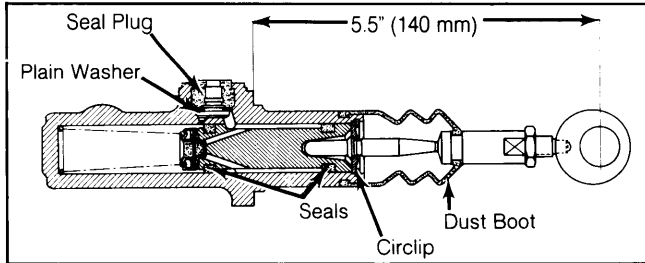

CLUTCH SLAVE CYLINDER

Remove retaining ring and take out push rod and boot. Remove piston and clean all internal parts with alcohol. Inspect bore for scoring and corrosion; replace if necessary. Lubricate all internal parts with brake fluid and reassemble.

Fig. 3: Sectional View of Clutch Slave Cylinder

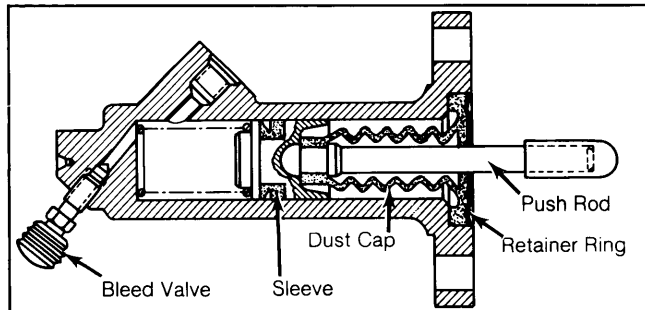

ADJUSTMENT

NOTE: Clutch free play is automatically adjusted for disc wear.

HYDRAULIC SYSTEM BLEEDING

Ensure that fluid reservoir is full and attach bleeder hose to bleed screw on slave cylinder. Submerge end of hose in partly filled container of brake fluid and pump clutch pedal about 10 times.

Hold pedal down on last stroke and loosen bleeder screw to allow air to escape. Close bleeder screw and repeat until air is bled from system.

TIGHTENING SPECIFICATIONS

Application	Ft. Lbs. (N.m)
Slave Cylinder-to-Clutch	
Housing Bolts	18-20 (24-27)
Clutch-to-Flywheel Bolts	16-17 (22-23)
Clutch Housing-to-Engine Bolts	
8 mm Bolts	18-20 (24-27)
10 mm Bolts	35-38 (47-51)
Cover-to-Clutch Housing Bolts	
6 mm Bolts	6-7 (8-9)
8 mm Bolts	18-20 (24-27)