

Volvo Engines

D24 6-CYLINDER DIESEL

ENGINE CODING

ENGINE IDENTIFICATION

The Volvo 6-cylinder diesel is designated model D24. Engine serial number is located under vacuum pump on left side of engine block. Vehicle Identification Number (VIN) is located on top of instrument panel at lower left of windshield.

ENGINE IDENTIFICATION

Application	Code
D24	
Man. Trans.	498704
Auto. Trans.	498705

ENGINE & CYLINDER HEAD

ENGINE

Removal

1) Disconnect battery. Disconnect windshield washer hoses and remove hood. Remove lower radiator hose, drain coolant, and remove coolant hoses attached to engine.

2) Remove radiator, expansion tank, and any attached hoses. Disconnect accelerator cable and vacuum lines.

3) Disconnect wires at main terminal, glow plug relay, and voltage regulator and hang out of way.

4) Remove power steering belt and pump with brackets, and hang out of the way with hoses attached. Remove and plug fuel lines at filter and injection pump.

5) Remove cooling fan and spacer, pulleys, and drive belts. Disconnect exhaust pipes at front and rear manifolds and remove air cleaner and ducting.

6) Drain engine oil. Disconnect driveshafts, speedometer cable, and gear lever from transmission.

7) On vehicles with manual transmission, disconnect clutch cable and pull out from clutch lever and housing. Position jack under transmission, raise slightly, and remove transmission crossmember. Detach engine mounts.

8) Attach lift 2810, and hooks 5185 and 5186, or a lifting device to engine. Move hoist to rear position on beam 2810, and hoist engine enough to off-load left engine mount.

9) Remove jack from under transmission. Move hoist to front position and carefully lift out engine, ensuring all wires and hoses clear assembly.

Installation

To install engine, reverse removal procedures.

CYLINDER HEAD

Removal

1) Remove splash guard, expansion tank cap, and lower radiator hose. Drain radiator and disconnect battery.

2) Remove radiator, fan, spacer, pulleys and fan belt. Remove drive belt for power steering. Remove valve cover and front and rear timing belt covers. Disconnect all wires to cylinder head.

3) Remove air cleaner and attached hoses. Disconnect vacuum pump and move to wheel housing. Remove vacuum pump plunger from cylinder head.

4) Remove and plug fuel delivery pipes and disconnect cold start device. Set No. 1 piston to TDC, (timing mark on flywheel at "0").

5) Loosen water pump retaining bolts to relieve tension on timing gear belt, and remove belt. Use wrench 5199 to hold camshaft drive gear in place.

6) Remove center retaining bolt. Camshaft MUST NOT rotate, or damage to valves and pistons could result.

7) Tap gear loose from camshaft tapered end. Remove injection pump drive belt by loosening retaining bracket bolts.

8) Use wrench 5199 to hold rear camshaft sprocket, and remove center retaining bolt. Tap gear loose from camshaft.

Fig. 1: Using Camshaft Gear Retaining Wrench

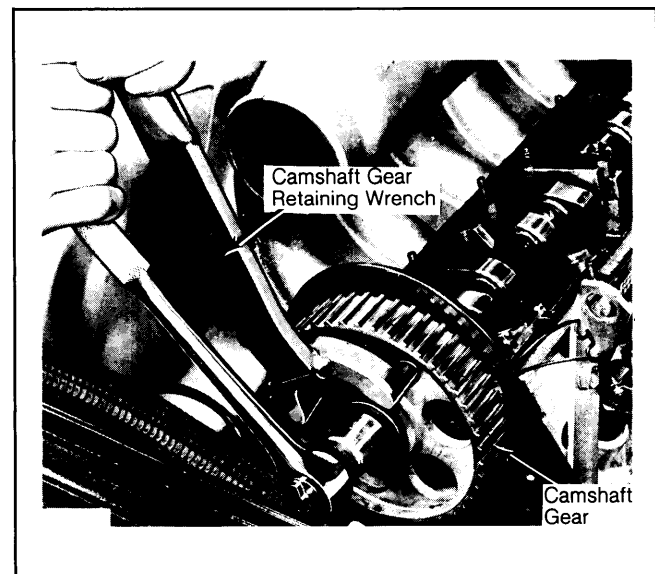

9) Loosen cylinder head bolts in reverse order of tightening sequence. Carefully lift cylinder head from engine.

10) Make sure rear glow plug clears injection pump bracket, and valves do not touch cylinder walls. Set cylinder head on wooden blocks so it does not rest on the valves.

Installation

1) Clean all mating surfaces and check that cylinder head is not warped. Maximum allowable distortion is .002" (.05 mm) diagonally, and .008" (.2 mm) crosswise.

NOTE: Cracks between valve seats not wider than .02" (.5 mm) do not warrant replacement of cylinder head, as they do not impair engine function.

2) Select a head gasket with the same number of notches as previous gasket, unless pistons, rods, or crankshaft were disassembled or repaired.

3) Piston projection above engine block must be measured. Use a dial indicator to measure each piston while at TDC, and select proper gasket from the Available Cylinder Head Gasket Table.

D24 6-CYLINDER DIESEL (Cont.)

AVAILABLE CYLINDER HEAD GASKETS

Piston Projection In. (mm)	Notches	Gasket Thickness
.026-.031 (.67-.80)	1	.055" (1.4 mm)
.032-.035 (.81-.90)	2	.059" (1.5 mm)
.036-.040 (.91-1.02)	3	.063" (1.6 mm)

4) Set No. 1 piston at TDC. Set camshaft for injection on cylinder No. 1 (both cam lobes of No. 1 cylinder should point up at equally large angles). Use stop tool 5190 to lock camshaft in place. Install aligning dowels 5234-3 in outer bolt holes.

5) Remove rear glow plug to protect it from hitting injection pump. Carefully set cylinder head into place.

6) Install the head bolts with new washers, coned side facing up and threads and washers oiled. Torque cylinder head bolts in 4 stages:

CYLINDER HEAD TIGHTENING SPECIFICATIONS

Sequence	Ft. Lbs. (N.m)
Stage 1	30 (40)
Stage 2	44 (60)
Stage 3	50 (75)
Stage 4	Additional 1/2 turn

Fig. 2: Cylinder Head Tightening Sequence

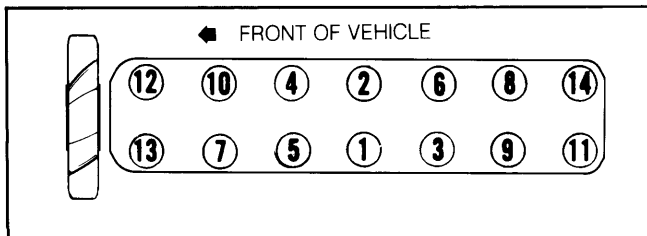

Loosen in reverse order.

7) Complete installation by reversing removal procedure. Run engine until it reaches operating temperature, and tighten cylinder head bolts in proper sequence an additional 1/4 turn.

NOTE: After 600-1200 miles, cylinder head bolts must be retorqued. Vacuum pump and plunger must be removed to gain access to cylinder head bolt. With the engine cool, tighten each bolt, in sequence, an additional 1/4 turn.

CAMSHAFT

TIMING BELT

Removal

1) Disconnect battery. Disconnect lower radiator hose and drain coolant. Remove coolant hoses attached to head.

2) Remove radiator, expansion tank cap, and engine splash guard. Remove fan, spacers, pulleys and fan belt.

3) Remove drive belt for power steering. Remove valve cover, and front and rear timing belt covers. Disconnect all wires to cylinder head.

4) Using a 1 1/16" (27 mm) wrench on crankshaft pulley bolt, bring No. 1 cylinder to TDC. Remove vibration damper center bolt using wrench 5187 to hold damper from turning.

5) Remove Allen screws and pull off vibration damper. Remove lower belt shield. Loosen water pump bolts and remove gear belt.

NOTE: Idler pulley must be replaced when replacing timing gear belt. Use puller 5202 or equivalent to remove pulley.

6) Using holding tool 5199 to keep camshaft from moving, remove center bolt on camshaft rear gear and tap gear off camshaft. Install camshaft locking gauge 5190 in groove on rear of camshaft.

7) Position a .008" (.2 mm) feeler gauge under left (injection pump) side of locking gauge. Remove camshaft front gear using holding tool 5199 to keep camshaft from turning while removing center bolt.

Fig. 3: Using Camshaft Locking Gauge to Set Timing

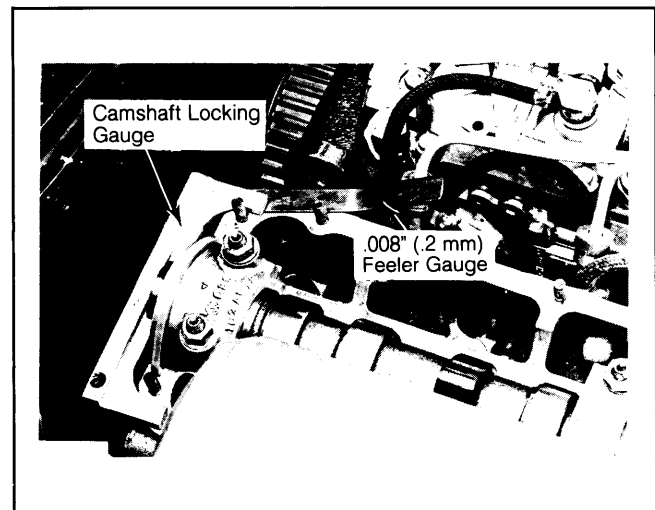

Installation

1) Making sure gear belt is fitted securely to all gears, install gear belt and camshaft front gear together. Install center bolt finger tight so gear can rotate.

2) Camshaft must not rotate. Install lower belt shield and vibration damper using sealing agent 277961-9 (or equivalent) on damper center bolt.

3) Check that No. 1 piston is at TDC and timing mark on flywheel is on "0". Adjust gear belt tension to 12-13 on tension gauge 5197 using the water pump for adjustment. Strike the belt heavily by hand and recheck tension.

4) Using wrench 5199 to hold gear, tighten camshaft front gear center bolt. Remove gauge 5190 and install rear camshaft gear without moving camshaft.

5) Install injection pump drive belt and adjust belt tension to 12-13 on tension gauge 5197. Reverse removal procedure to complete installation.

CAMSHAFT

Removal

With camshaft drive sprockets and vacuum pump removed, and engine at TDC, remove bearing caps 1 and 4. Alternately loosen cap nuts on caps 2 and 3. Lift out camshaft and remove seals.

Volvo Engines

D24 6-CYLINDER DIESEL (Cont.)

Installation

1) Lightly lubricate bearings and contact surfaces. Install gauge 5190 on camshaft rear and position camshaft on cylinder head.

2) Cam lobes for cylinder No. 1 should point up at equally large angles. Install bearing caps 2 and 3 and tighten cap nuts alternately. Use gauge 5190 to guide rear end when tightening. Remove gauge.

Fig. 4: No. 1 Cylinder, Top Dead Center Reference Mark

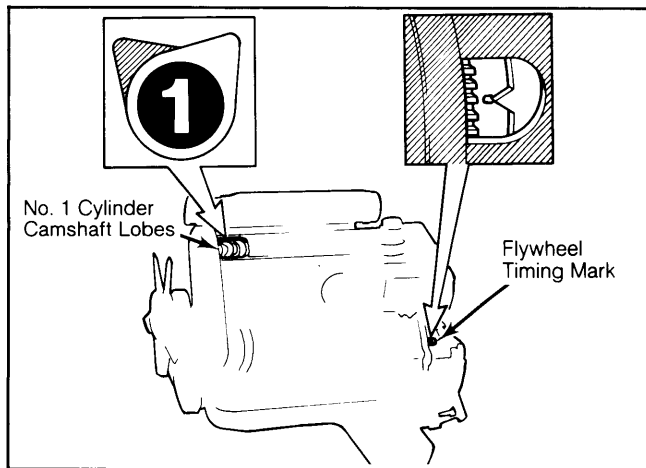

3) Install new oil seals on camshaft, but do not press them to bottom. Make sure seals are not cocked.

4) Install bearing caps 1 and 4. Use adaptor 5200 and press seals into final position. Reverse removal procedure to complete installation.

INJECTION PUMP

Removal

1) Pinch off hoses to cold start device and disconnect. Disconnect accelerator cable and automatic transmission kickdown cable (if equipped).

2) Remove rear timing gear cover, vacuum pump, and fuel delivery pipes. Plug all fuel lines and connections to prevent contamination of fuel system.

3) Disconnect wire at stop valve. Turn crankshaft pulley to bring No. 1 piston to TDC. Loosen injection pump bracket bolts to relieve belt tension and remove drive belt. Tighten one bolt to retain pump in an upright position.

4) Loosen camshaft rear gear center bolt enough to allow gear to rotate on camshaft without letting camshaft rotate. Lock injection pump gear with stop 5193, and remove gear nut.

5) Using puller 5204, remove injection pump gear. Remove bolts retaining front injection pump bracket to engine. Bracket comes out with pump. Remove Allen screws retaining injection pump, and remove pump.

Installation

To install, reverse removal procedure, noting that mark on injection pump and bracket coincide, and shaft key is correctly installed before replacing gear.

Pump Timing

1) To check pump timing remove rear timing belt cover and set No. 1 piston to TDC. Disconnect cold start device by loosening the screw nearest the lever, and pushing lever forward.

2) Rotate sleeve 90° and push lever back against stop. DO NOT loosen clamp screw at end of cable.

3) Install a dial indicator with adaptor 5194 in place of plug at injector pump distributor. Set dial indicator with .08" (2 mm) preload between plunger and pump shaft. Turn crankshaft counterclockwise until dial indicator is at minimum reading.

4) Set dial indicator to zero and turn crankshaft to bring No. 1 piston back to TDC. Dial indicator reading should now be .028" (.70 mm). If necessary, loosen injection pump retaining screws and turn pump to obtain proper setting.

5) Tighten screws and rotate crankshaft 2 complete turns, bringing No. 1 piston back to TDC. Dial indicator should still read .028" (.07 mm).

6) Readjust and recheck as necessary to obtain proper setting. Remove dial indicator, and install timing gear cover and cold start device.

VALVES

VALVE ARRANGEMENT

E-I-E-I-E-I-E-I-E-I-E-I-E (Front-to-rear).

VALVE CLEARANCE ADJUSTMENT

1) Remove valve cover and rotate crankshaft so that No. 1 piston is at TDC, and cam lobes point up. Flywheel mark should be at "0".

2) Check intake and exhaust clearance between heel of cam lobe and cam follower. Check remaining cylinders in firing order sequence.

3) If adjustment is required, turn the crankshaft 1/4 turn clockwise from piston TDC, as there is no room to depress valves. Using depressor tool (5196), press down valve depressor and remove disc with special pliers (5195).

4) Calculate thickness of disc required to reach proper setting. Discs are available in thicknesses of .130-.167" (3.30-4.25 mm) in increments of .002" (.05 mm).

5) Lubricate and position new disc with stamped marking down. Rotate crankshaft several times and recheck all settings. Install valve cover.

VALVE CLEARANCE SPECIFICATIONS

Application	In. (mm)
Intake	
Hot008-.012 (.20-.30)
Cold006-.010 (.15-.25)
Exhaust	
Hot016-.020 (.40-.50)
Cold014-.018 (.35-.45)

VALVE GUIDE SERVICING

1) With cylinder head removed from engine, and camshaft and lifters removed, attach a valve spring compressor to valve.

2) Compress valve spring and remove retaining lock, upper valve spring washer, valve springs, and valve. Remove valve guide seals and lower valve spring washers.

3) Using a dial indicator, measure valve guide clearance by placing a new valve in guide bore with a valve stem end edge to edge with valve guide. Use proper intake or exhaust valve for bores as stem diameters are different.

D24 6-CYLINDER DIESEL (Cont.)

4) Rock valve back and forth and observe dial indicator reading. Clearance must not exceed .051" (1.3 mm).

5) If clearance is excessive, replace valve guides. Press out old guides from combustion chamber side of cylinder head using a drift (5218 or equivalent).

6) Oil replacement valve guide and press in place from camshaft side of cylinder head until guide flange bottoms in cylinder head.

7) Do not use more than 1 ton force, or flange may break off of guide. Ream guides using hand reamer (5224 or equivalent).

NOTE: Valves and seats must be reground if valve guides are replaced.

8) Replace valve components, camshaft, and cylinder head in reverse order of removal.

PISTONS, PINS & RINGS

PISTON & ROD ASSEMBLY

Removal

1) With oil pan and cylinder head removed, mark each piston assembly for proper installation. Ream any ridge from cylinder bores using a ridge reamer. Place a rag on top of piston to collect cuttings.

2) Remove connecting rod cap and bearing shells, and push piston assembly out through top of cylinder bore.

Installation

1) Fit bearing shells in connecting rod and rod cap. Lubricate cylinder bores, pistons, and bearing shells. Turn crankshaft so that journal for piston being serviced is at bottom of stroke.

2) Using a ring compressor, fit piston to bore noting that arrow on piston crown faces forward. Push piston down, and locate connecting rod to crankshaft.

3) Fit rod cap to connecting rod and tighten new nuts. Install all pistons and check that crankshaft rotates freely.

FITTING PISTONS

1) Using a bore indicator, measure each cylinder bore at 3 points, both parallel and at right angles to crankshaft. Measure .393" (10 mm) from top, bottom, and at center of cylinder bore.

2) The cylinder bore reading must not deviate by more than .002" (.04 mm) from basic value.

3) Measure piston diameter at right angle to piston pin .590" (15 mm) from lower edge. Subtract reading from that taken of cylinder bore. If specifications are exceeded, reboring or oversize pistons must be used.

NOTE: Pistons with rounded edges on pressure side may not be used again. Round edges are caused by faulty injectors, which must be serviced before installation.

4) Place each piston ring squarely into bottom of cylinder bore and measure ring gap. Place ring approximately .59" (15 mm) from lower edge of cylinder.

PISTON PINS

Removal

Remove circlips retaining piston pin. Push out pin with a drift. If pin moves stiffly, heat piston to approximately 140°F (60°C)

Installation

1) Assemble in reverse order. If piston pin bushing warrants replacement, press bushing out using drift (5017 or equivalent). Press in new bushing until edges are flush with connecting rod.

2) Drill out lubricating hole in bushing and ream bushing with a reamer. Piston pin must be loose, but still able to slide through hole with slight resistance.

PISTON RINGS

Removal

Using ring pliers, remove rings from piston. Remove any carbon deposits from ring lands and piston.

Installation

1) Fit expander ring in lowest groove of piston. Fit oil ring so ring gap is opposite spring opening. Install lower compression ring with "Top" marking upward.

2) Install upper compression ring. Turn compression rings so all gaps are 120° apart. Do not turn oil control ring.

CRANKSHAFT MAIN & CONNECTING ROD BEARINGS

MAIN & CONNECTING ROD BEARINGS

Removal

1) Check markings on main and connecting rod bearings and remark if necessary. Using Plastigage method check main and connecting rod bearing clearance.

2) If clearance is excessive, replace bearings. Do not mix old and new bearings. Replace in sets only.

Installation

1) Fit main bearing shells in engine block and main bearing caps. Install bearing shells with oil hole to engine block. Lubricate bearings and place crankshaft in position.

2) Fit main bearing caps with No. 1 toward vibration damper and No. 7 toward flywheel. See Piston and Rod Assembly for connecting rod installation procedure.

Crankshaft Front Seal

With vibration damper removed, pull old seal from housing using puller 5205 (or equivalent). Grease seal lips, and press into place by hand. Use adapter 5200, a thick washer and camshaft center bolt to press seal into housing until seated.

Crankshaft Rear Seal

With flywheel removed, pry out old seal with a screwdriver. Coat seal contact surfaces and lips with oil and hand start into position. Tap seal into housing until it bottoms, using drift 5208 (or equivalent).

ENGINE OILING

CRANKCASE CAPACITY

7.4 quarts (7.0L) with filter change, and 6.6 quarts (6.2L) without filter change.

OIL FILTER

Replaceable spin-on type.

NORMAL OIL PRESSURE

Minimum of 28 psi (2 kg/cm²) @2000 RPM with engine at normal operating temperature.

Volvo Engines

D24 6-CYLINDER DIESEL (Cont.)

ENGINE OILING SYSTEM

Gear-type oil pump pressure lubricates pistons, piston pins, and crankshaft. Three nozzles in the head distribute oil to cam lobes, valve depressors and vacuum pump piston.

OIL PUMP

The oil pump cannot be removed without removing the engine. No repairs can be made in the vehicle. The oil pump must be replaced as an assembly as there are no separate replaceable parts.

ENGINE COOLING

COOLANT CAPACITY

10 qts. (9.4L).

THERMOSTAT

Begins to open at 186°F (87°C), and is fully open at 236°F (102°C).

NOTE: When filling the cooling system, air must be bled out of the system by disconnecting the upper hose from the cold start device and setting the heater in the high position. Fill system, run engine for 5 minutes while continuing to fill system. Reconnect hose and complete filling.

WATER PUMP

Removal

Remove timing belt as described in Timing Belt Removal, making sure to mark belt position on belt,

camshaft and crankshaft gears. Also, mark belt as to which parts face upward and forward. Remove protective plate and pump retaining bolts, and remove water pump.

Installation

Making sure all gasket surfaces are clean, lightly grease a new "O" ring and fit it to the pump. DO NOT use any other sealing agent. Install the pump with the longest retaining bolt in the upper hole. Reverse removal procedure to complete installation.

TIGHTENING SPECIFICATIONS

Application	Ft. Lbs. (N.m)
Camshaft Gear Center Bolt	33 (45)
Camshaft Gear Bolt (Rear)	74 (100)
Camshaft Pulley Nut	255 (350)
Camshaft Bearing Caps	15 (20)
Cylinder Head Bolts	
Step 1	30 (40)
Step 2	44 (60)
Step 3	50 (75)
Step 4	Additional 1/2 turn
Hot torque	Additional 1/4 turn
After 600-1200 miles	Additional 1/4 turn
Connecting Rod Cap Nuts	35 (45)
Exhaust Manifold Bolts	18 (25)
Flywheel Bolts	55 (75)
Intake Manifold Bolts	18 (25)
Main Bearing Cap Bolts	50 (65)
Transmission-to-Engine	35 (48)
Pump Gear	33 (45)

ENGINE SPECIFICATIONS

GENERAL SPECIFICATIONS

Year	Displacement		Fuel System	HP@RPM	Torque Ft. Lbs.@RPM	Compr. Ratio	Bore		Stroke	
	Cu. In.	cc					In.	mm	In.	mm
1982	145	2383	Fuel Inj.	76@4800	98@2800	23.5:1	3.01	76.5	3.40	86.4

VALVES

Engine Size & Valve	Head Diam. In. (mm)	Face Angle	Seat Angle	Seat Width In. (mm)	Stem Diameter In. (mm)	Stem Clearance In. (mm)	Valve Lift In. (mm)
2383 cc Intake	1.417 (36.0)	44.5°	45°	.079 (2.0)	.314 (7.97)	.0118 (.30)	.335 (8.5)
Exhaust	1.221 (31.0)	45°	45°	.094 (2.4)	.313 (7.95)	.0118 (.30)	.354 (9.0)

¹ — Wear limit .05" (1.3 mm)

Volvo Engines

6-393

D24 6-CYLINDER DIESEL (Cont.)

ENGINE SPECIFICATIONS (Cont.)

PISTONS, PINS, RINGS

Engine	PISTONS	PINS		RINGS		
	Clearance In. (mm) ¹	Piston Fit In. (mm)	Rod Fit In. (mm)	Ring No.	End Gap In. (mm) ²	Side Clearance In. (mm)
2383 cc	.0012-.0019 (.03-.05)	Push Fit	Close Running Fit	Comp. 1 Comp. 2 Oil	.012-.020 (.30-.50) .012-.020 (.30-.50) .010-.016 (.25-.40)	.0023-.0035 ³ (.06-.09) .0019-.0031 ³ (.05-.08) .0011-.0023 ⁴ (.03-.06)

¹ — Wear limit .0051" (.13 mm) ² — Wear limit .040" (1.0 mm) ³ — Wear limit .0078" (.2 mm) ⁴ — Wear limit .0059" (.15 mm)

CRANKSHAFT MAIN & CONNECTING ROD BEARINGS

Engine	MAIN BEARINGS				CONNECTING ROD BEARINGS		
	Journal Diam. In. (mm)	Clearance In. (mm) ¹	Thrust Bearing	Crankshaft End Play In. (mm) ²	Journal Diam. In. (mm)	Clearance In. (mm) ³	Side Play In. (mm)
2383 cc	2.283 (58.0)	.0006-.0029 (.016-.075)	No. 4	.003-.007 (.07-.18)	1.88 (47.8)	.0006-.0024 (.015-.062)	.0157 (.40)

¹ — Wear limit .0063" (.16 mm) ² — Wear limit .010" (.25 mm) ³ — Wear limit .0047" (.12 mm)

CAMSHAFT

Engine	Journal Diam. In. (mm)	Clearance In. (mm) ¹	Lobe Lift In. (mm)
2383 cc Front	1.257-1.258 (31.92-31.95)	.002-.004 (.05-.10)
Others	1.1786-1.1795 (29.94-29.96)	.002-.004 (.05-.10)	

¹ — End play .006" (.15 mm)

VALVE SPRINGS

Engine	Free Length In. (mm)	PRESSURE Lbs. @ In. (Kg @ mm)	
		Valve Closed	Valve Open
2383 cc Inner	1.33 (33.9)	16.2@1.13 (7.3@28.6)	49.4@.72 (22.0@18.3)
Outer	1.58 (40.2)	40.0@1.28 (18.0@32.6)	102.5@.89 (46.0@22.3)