

## B28F V6

### ENGINE CODING

#### ENGINE IDENTIFICATION

Engine identification number is located on the front left side of engine block, below the exhaust manifold, and above the power steering pump bracket. Vehicle Identification Number (VIN) is located on top of instrument panel at lower left of windshield.

#### ENGINE IDENTIFICATION NUMBERS

Application	Man. Trans.	Auto. Trans.
GLE & Coupe (2849 cc)		
Federal .....	498640 .....	498641
California .....	498638 .....	498639

### ENGINE, MANIFOLDS & CYLINDER HEAD

#### ENGINE

##### Removal

1) Remove gearshift lever (manual) or place lever in "P" (automatic). Remove battery, hood, air cleaner, and engine splash guard.

2) Drain cooling system (each side of block), and disconnect all coolant hoses. Disconnect automatic transmission oil cooler pipes at radiator.

3) Remove radiator and fan shroud. Disconnect heater hose at intake pipe, power brake hose at intake manifold, and vacuum pump hose at pump. Remove vacuum pump.

4) Disconnect fuel hoses at filter and return pipe. Disconnect wiring harness and relay connectors. Remove high tension lead from distributor and heater hoses at fire wall. Disconnect carbon filter hose at filter, and hose from EGR valve.

5) Remove connector at voltage regulator and wire clamp. Disconnect connector for distributor, throttle cable, vacuum amplifier hose at T-pipe, and wax thermostat hoses.

6) Remove hose from air pump to backfire valve and wires from solenoid valve and micro switch. Remove nuts from both exhaust manifold flanges.

7) Remove A/C compressor and drive belt without disconnecting hoses. Drain engine oil. Remove power steering pump and belt.

8) Remove nuts from front engine mounts. Remove exhaust pipe clamps (front exhaust pipe with catalytic converter). Disconnect shift control lever at automatic transmission.

9) Disconnect slave cylinder from clutch (manual transmission) and detach speedometer cable. Disconnect propeller shaft. Put stands under front of car, and using wooden block, place jack under oil pan. Remove transmission attachment member.

10) Using sling and hoist, lift engine/transmission assembly from car.

**NOTE:** When removing engine, check for hoses and wires not previously removed.

##### Installation

To install, reverse removal procedures.

### CYLINDER HEAD & MANIFOLDS

#### Removal

1) Disconnect battery ground cable. Remove air cleaner and disconnect throttle cable. Disconnect kick-down cable (automatic transmission) and remove pipe from EGR valve and intake manifold.

2) Disconnect vacuum hose at EGR valve. Remove oil filler cap and stuff rag in filler hole. Disconnect crankcase ventilation pipe from intake manifold and remove intake manifold front, gaskets, and rubber rings.

3) Disconnect fuel line and connector from cold start injector. Disconnect vacuum hose, connector and two fuel lines from control pressure regulator.

4) Disconnect hoses, pipes and electrical connectors, and remove auxiliary air valve. Remove connector at fuel distributor and wiring harness. Disconnect high tension leads from spark plugs and injectors from holders in both banks.

5) Disconnect vacuum hose at distributor, and remove vacuum, carbon filter, diverter valve, power brake, and heater hoses at intake manifold. Disconnect wires at throttle micro switch and solenoid valve, and fuel lines from filter and return pipe. Remove fuel distributor.

6) Disconnect EGR valve hose from throttle housing. Remove cold start injector and pipe. Remove intake manifold and rubber rings. Remove splash guard under engine and drain coolant from both sides of block.

7) Remove air pump, vacuum pump and vacuum hoses at thermostat. Disconnect upper radiator hose and remove A/C compressor (do not remove hoses).

8) Remove distributor and EGR valve and bracket. Disconnect relay connectors and remove rear A/C bracket. Remove lower radiator hose at water pump and hoses from pump to cylinder heads.

9) Disconnect supply hose from cylinder heads, and separate air manifold at rear of engine. Remove backfire valve and air hose. Remove valve covers.

10) On left side, remove four upper timing gear cover bolts and Allen head screw (not camshaft center bolt). On right side, remove four upper timing gear cover bolts and cover plate.

Fig. 1: Cylinder Head Bolt Pattern

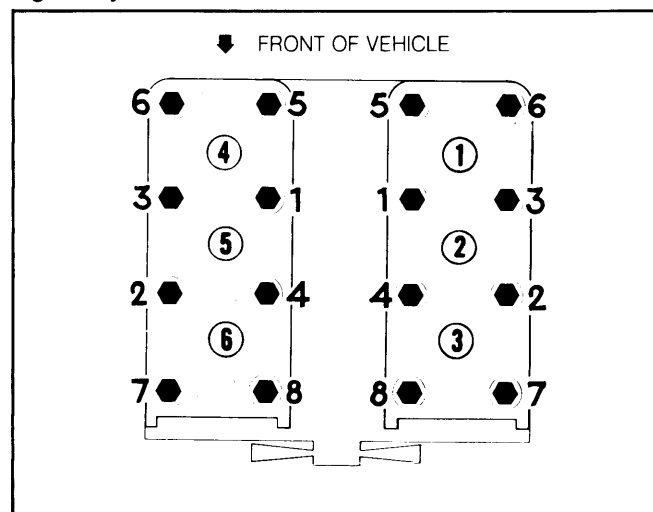

Follow this sequence when removing and installing cylinder head bolts.

# Volvo Engines

## B28F V6 (Cont.)

Fig. 2: Cylinder Head Removal



Use of special tools indicated will aid in removal and installation.

**11)** Remove exhaust pipe clamps from under vehicle, and remove oil dipstick tube. Remove exhaust pipe flange nuts and exhaust manifold. Remove cover plates at rear of cylinder heads.

**12)** Rotate each camshaft until large hole in sprocket aligns with rocker arm shaft. Remove rocker arm and shaft assembly by removing bolts in sequence shown in Fig. 1. Loosen bolt and push camshaft lock fork to one side.

**13)** Install tool to hold camshaft sprocket in place (5104). With tool installed, remove camshaft center bolt and slide camshaft to rear. Be sure camshaft stud is free from sprocket.

**NOTE:** If tool is not used, camshaft chain will slacken and be held by chain tensioner. Sprocket then cannot be pulled upward when installing camshaft. If this should occur, timing gear cover must be removed for access to chain tensioner.

**14)** Insert two 12" long rods into cylinder head bolt holes, Fig. 2, and push downward to loosen cylinder head from block. Do not attempt to remove cylinder head by lifting straight upward.

**15)** If liners are not to be removed, be sure they do not separate from their seals in lower liner seat. If seals are damaged, coolant will enter crankcase. Lift out cylinder head carefully.

**16)** Tap guide sleeves flush with block face and remove gasket. Install liner holders (5093) to secure liners against seat seals.

**17)** Clean gasket surfaces and install camshaft retaining tool (5105). After tool is securely in place, remove fixing bolt from previously installed tool (5104). See Fig. 2.

**NOTE:** Sprocket retaining tool (5105) should be kept securely in place while cylinder heads are removed. This prevents camshaft chains from slackening, yet permits turning of crankshaft.

### Installation

**1)** Insert fixing bolt into camshaft sprocket retainer (5104) and remove other retainer (5105) from

cylinder block face. Pull up on guide sleeves and insert a 1/8" drill bit under each sleeve.

**2)** Remove liner holders (5093) and position cylinder head gasket on block face (left and right gaskets differ). Install cylinder head with one bolt and push camshaft into camshaft sprocket.

**3)** Install camshaft center bolt, but do not torque. Remove drill bits from under guide sleeves.

**4)** Position rocker arm and shaft assembly and install cylinder head bolts. Tighten all bolts in sequence shown in Fig. 1 in three stages.

### CYLINDER HEAD TIGHTENING SPECIFICATIONS

Sequence	Ft. Lbs. (N.m)
First Step .....	7 (10)
Second Step .....	22 (30)
Third Step .....	44 <sup>1</sup> (60)

<sup>1</sup> — After third step, tightening must be completed using a protractor. Proceed to step 5).

**5)** Torque camshaft center bolt and remove sprocket retainer (5104). Center lock fork over camshaft and tighten. Back off all cylinder head bolts in sequence. See Fig. 1. Tighten to 11-14 ft. lbs. (15-19 N.m).

**6)** Using protractor (5098) on standard socket, complete tightening of head bolts as follows: Start with bolt one, take up slack of tool. Set protractor so "0°" mark aligns with rocker arm and shaft assembly. Tighten bolt 116-120°. Repeat procedure in proper tightening sequence on other head bolts.

**7)** After engine is assembled, run engine for 15 minutes and cool for 30 minutes. Back off head bolts once more and torque to 11-14 ft. lbs. (15-19 N.m). Using protractor again, torque to 113-117° in sequence.

**8)** Install remainder of components in reverse order of removal procedure, noting the following: Before installing valve cover, adjust valves (cold setting). When installing distributor, rotor should initially point to clamp clockwise from mark on distributor housing.

**9)** Crankshaft should still be in position for firing No. 1 cylinder following valve adjustment. When distributor is pushed into place, rotor will point to mark on

## B28F V6 (Cont.)

**Fig. 3: Final Tightening of Cylinder Head Bolts**

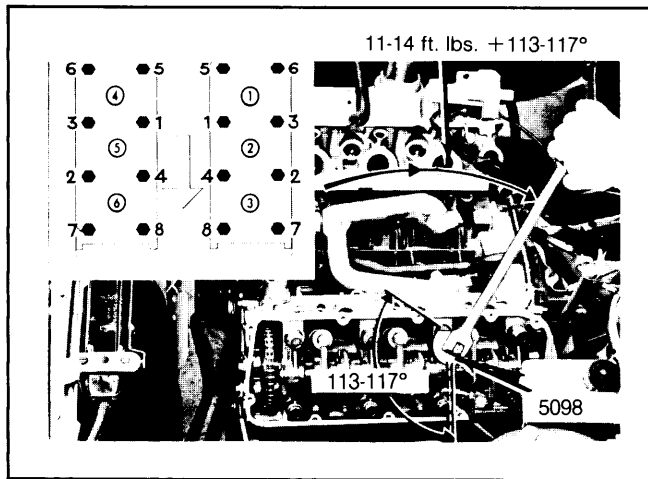

Perform this step only after running and cooling engine.

housing. See Fig. 4 & 5. Use new gaskets and rubber sealing rings. Be sure to fill engine with oil and coolant.

**Fig. 4: Distributor Installation**

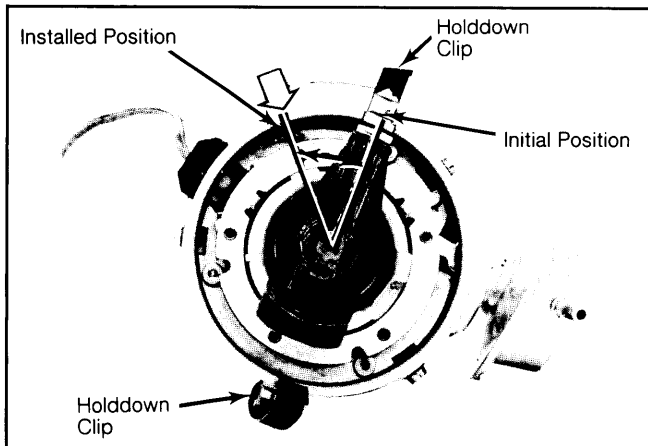

Align rotor as shown prior to installation.

### CAMSHAFT

#### CAMSHAFT

##### Removal

With cylinder head removed, remove lock fork and rear cover plate. Pull camshaft out from rear of head.

##### Installation

To install, place camshaft in from rear of cylinder head. Note that camshaft for right bank has distributor drive gear at rear end. Install lock fork at front and cover plate at rear of head.

### TIMING GEAR COVER

#### Removal

Remove both valve covers, lock flywheel (5112), and remove crankshaft nut. Remove pulley while key is on top of shaft (prevents dropping key in crankcase). Use puller (5069) to remove crankshaft seal. Remove timing gear cover.

#### Installation

Clean surfaces and place gaskets on block and timing gear cover. Install cover and tighten bolts to 7-11 ft. lbs. (10-15 N.m). Install crankshaft seal (drift 5103). Block flywheel with locking tool (5112), install pulley and tighten crankshaft nut to 118-132 ft. lbs. (160-180 N.m).

### CHAINS & SPROCKETS

#### Removal

1) Remove timing gear cover, oil pump chain, sprocket, oil pump and gears. Turn each tensioner lock 1/4 turn counterclockwise and push in piston to slacken camshaft chains.

2) Remove both tensioners, strainers, and curved and straight dampers. Remove camshaft sprockets and chains.

3) Stuff rag in holes near crankcase to keep key from falling in crankcase. Remove outer sprocket and inner double sprocket from crankshaft (either by hand or with puller).

#### Installation

1) Place key in crankshaft. Oil Sprocket and shaft. Install double sprocket (drift 4028) with mark outward. Install spacer ring and outer key. Install oil pump sprocket, strainers and chain tensioners, and curved and straight dampers.

2) Rotate crankshaft so key aligns with camshaft in left bank (No. 1 cylinder at TDC). Position camshaft so key points upward (rocker arms for No. 1 cylinder rock).

3) Place chain on camshaft sprocket so that link between two white lines is centered over camshaft sprocket timing mark. Place chain on inner crankshaft sprocket so timing mark on sprocket is aligned with white mark on chain.

4) Install left camshaft sprocket onto camshaft so that pin on sprocket slips into recess in camshaft. Chain should be stretched on tension side. Use screwdriver to hold sprocket and tighten center bolt to 51-59 ft. lbs. (69-80 N.m).

**Fig. 5: Crankshaft Timing Marks**

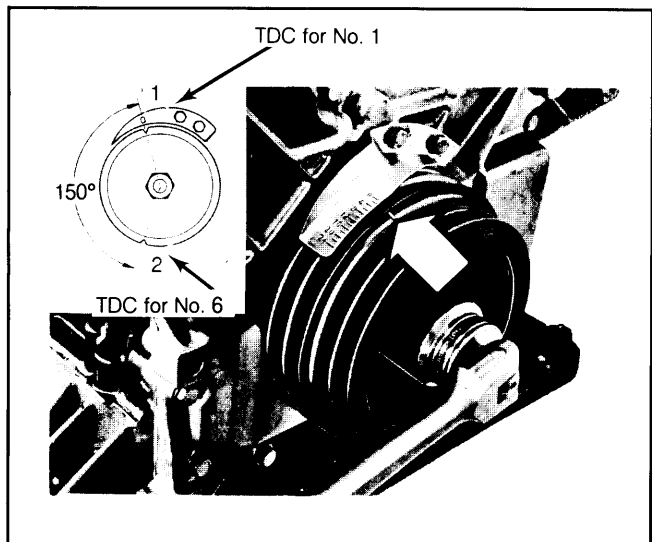

Set crankshaft to firing position for No. 1 cylinder.

# Volvo Engines

## B28F V6 (Cont.)

5) Rotate crankshaft clockwise 150° so that key points straight downward. Set right camshaft so keyway is in position shown in Fig. 6.

6) Place chain on sprocket so link between white lines on chain aligns with sprocket timing mark. Place chain on crankshaft center sprocket so that chain and sprocket timing marks align.

7) Fit sprocket on camshaft with chain stretched on tension side. Pin on sprocket should slip into camshaft recess. Use screwdriver to hold sprocket and torque center bolt to 51-59 ft. lbs. (69-80 N.m).

**Fig. 6: Right Camshaft Sprocket**

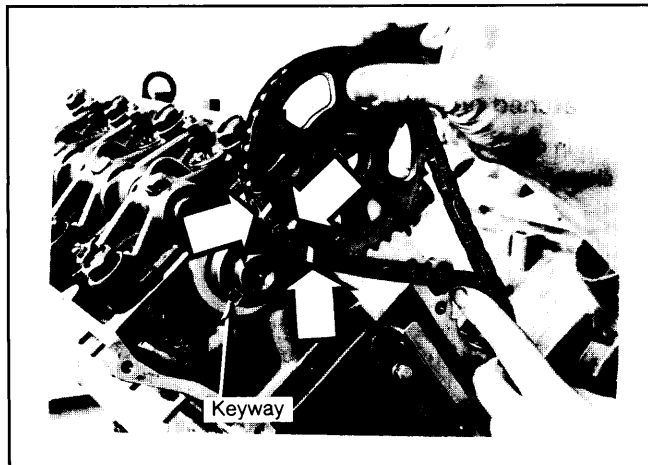

Align timing marks and keyway as shown.

8) Turn lock on each chain tensioner 1/4 turn clockwise. Tension chains by rotating crankshaft 2 full turns in direction of rotation (clockwise). Remove crankshaft nut.

9) Markings on chains and sprockets will no longer align. Reassemble oil pump, install chain and chain sprocket. Install timing gear cover after removing rag from crankcase holes.

**Fig. 7: Locating Top Dead Center of No. 1 Cylinder**

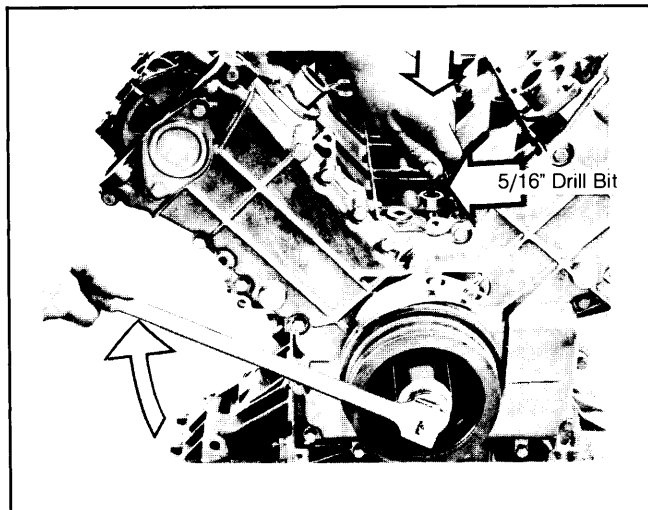

Use a 5/16" rod or drill bit up to 10" long.

### IGNITION TIMING PLATE

1) Rotate crankshaft so that mark No. 1 is at 20° mark on ignition timing plate. See Fig. 5.

2) Remove plug and insert 5/16 (7.94 mm) drill bit or similar rod into hole and against crankshaft counterweight. See Fig. 7. Rotate crankshaft in direction of normal rotation until drill bit can be pressed into recess in counterweight (TDC for No. 1 cylinder).

**NOTE:** Do not drop drill bit into engine. Use drill or rod up to 10" long.

3) Loosen two bolts and adjust ignition timing plate so that "0" mark is aligned with pulley mark. Tighten two bolts, remove drill bit or rod and install plug. Check camshaft setting.

4) Valve clearance should be .028" (.7 mm). Intake valves for cylinders No. 1 and 6 should open between 6 and 12 degrees on crankshaft vibration damper.

### ROCKER ARM ASSEMBLY

#### Removal

1) Mark rocker assemblies as to which head they belong. Remove lock ring from end of shaft, and remove rocker arms, shaft supports, spacer sleeves, and springs. Keep all parts in order for correct assembly.

2) Remove the lock bolt and rocker shaft support from rocker shaft. Check shaft-to-arm clearance. New part clearance is .0005-.0021" (.012-.054 mm). New shaft diameter is .7858-.7866" (19.96-19.98 mm). Replace worn parts as necessary.

#### Installation

1) Install rocker shaft support on rocker shaft with lubricating holes pointing downward. The flat top surface should face toward lock ring groove in other end of shaft. Tighten lock bolt.

2) Install thick spacer, exhaust rocker arm, thin spacer, intake rocker arm, spring, and rocker shaft support, in order. After installing 2 more such sets, install lock ring in rocker shaft groove.

### VALVES

#### VALVE ARRANGEMENT

##### Right Bank

E-I-E-I-E-I (Front-to-rear).

##### Left Bank

I-E-I-E-I-E (Front-to-rear)

#### VALVE STEM OIL SEALS AND VALVE SPRINGS

1) With cylinder head removed from engine, remove spark plugs, injectors, rear cover plate, lock fork and camshaft.

2) Using valve spring compressor, remove valve collets, spring retainer, spring, lower spring seat and valve. Remove valve guide seal from guide. Place valves in order in rack.

#### VALVE GUIDE SERVICING

1) Check valve guides for wear. If replacement is necessary, press out old guide using drift (2818). Ream hole in cylinder head to oversize class 1 or 2:

2) Using drifts (5108 for intake; 5109 for exhaust), press in new guides. Ream guides to .3150-.3158" (8.00-8.02 mm). Check for burrs and be sure valves move freely in guides.

## B28F V6 (Cont.)

### VALVE GUIDE SPECIFICATIONS

Application	Diameter In. (mm)
Cyl. Head Hole, Class 1 .....	.5193-.5209 (13.19-13.23)
Cyl. Head Hole, Class 2 .....	.5311-.5327 (13.49-13.53)
Valve Guide, Class 1 .....	.5228-.5232 (13.28-13.29)
Valve Guide Class 2 .....	.53460.5350 (13.58-13.59)

<sup>1</sup> — Oversize valve guides shown.

### RECONDITIONING VALVES

1) After inspection, grind valves, mill or grind valve seats, and lap valves with grinding paste, as necessary. Check valve springs for proper length and tension.

2) Install seals, valves, spring seats, spring, and spring retainers. Compress spring and install collets. Remove tool, and reinstall all parts previously removed from cylinder head.

### VALVE CLEARANCE ADJUSTMENT

1) Rotate crankshaft with 1 7/16" (36 mm) wrench to bring No. 1 piston to TDC. See Fig. 5. In this position, both rocker arms for No. 1 cylinder should have clearance and not rock.

2) Check and adjust the following cylinders for clearance: Intake valves on cylinders 1, 2, and 4; exhaust valves on cylinders 1, 3, and 6 (White valves in Fig. 8).

Fig. 8: Valve Clearance Adjustment Sequence

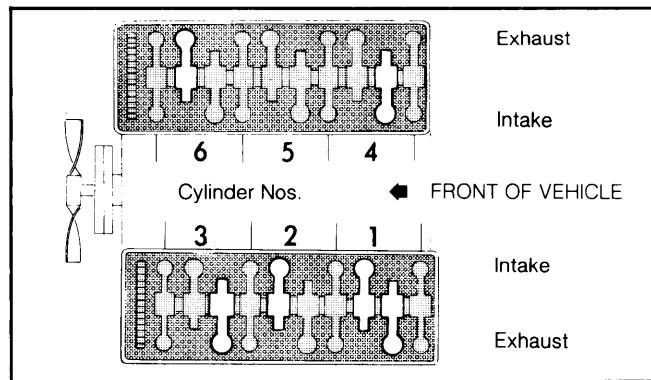

Adjust valves with engine cold.

### VALVE CLEARANCE SPECIFICATIONS <sup>1</sup>

Valve	In. (mm)
Intake .....	.004-.006" (.10-.15 mm)
Exhaust .....	.010-.012" (.25-.30 mm)

<sup>1</sup> — Specifications are for a cold engine.

3) Rotate crankshaft one full turn so marking is again opposite 0° mark. Rocker arms for No. 1 cylinder will now rock. Check and adjust the following cylinders for clearance: Intake valves on cylinders 3, 5, and 6; exhaust valves on cylinders 2, 4, and 5 (Gray valves in Fig. 8).

## PISTONS, PINS & RINGS

### LOWER CRANKCASE

#### Removal

Remove oil pan and gasket, oil strainer and baffle plate. Remove 14 crankcase bolts and 8 main

bearing nuts. Lift off lower crankcase. Install main bearing cap retainers (5096) on two outer bearings.

#### Installation

1) Install rubber ring for oil channel. Clean and apply sealing compound to crankcase and block surfaces. Remove main bearing cap retainers and install lower crankcase.

Fig. 9: Main Bearing Cap Bolt Pattern

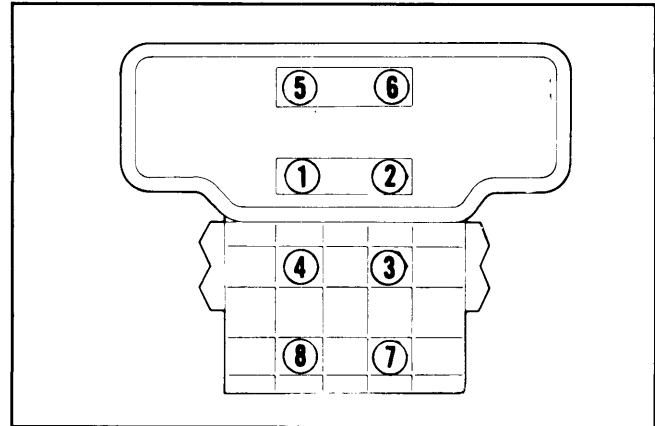

Follow sequence shown when tightening bearing cap nuts.

2) Be sure crankcase and block are flush at rear end and tighten main bearing nuts to 22 ft. lbs. (30 N.m) torque. Use sequence shown in Fig. 9, then back off No. 1 nut and retorque to 22-25 ft. lbs. (30-34 N.m).

3) Using protractor tool (5098), tighten nut an additional 73-77°. Continue in sequence, backing off each nut, torque tightening, and then angle tightening to specifications.

4) Tighten 14 lower crankcase bolts to 11-15 ft. lbs. (15-20 N.m). Install baffle plate, oil strainer, gasket and oil pan.

## PISTON & ROD ASSEMBLIES

### Removal

1) Remove lower crankcase and cylinder heads. Install cylinder liner holders (5093) to keep liners from being pushed out with piston. Check connecting rod and crankshaft markings so piston assemblies can be installed in their original positions.

2) Connecting rods are marked "A" through "F" from rear of engine to front. Remove cap nuts and bearing

Fig. 10: Piston Ring Installation

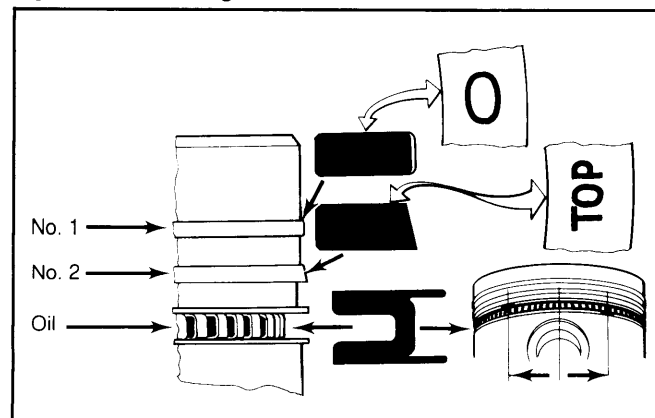

Install rings with identification mark facing upward.

# Volvo Engines

## B28F V6 (Cont.)

cap and push piston assembly out through top of bore. Remove big end bearing.

3) Remove piston rings and clean ring grooves and piston of any carbon deposits. Measure the side clearance and end gap of piston rings with a feeler gauge. Replace any components not within specifications.

### Installation

1) Install piston rings with end gaps at 120° angles from each other. Offset the gaps on the oil control rings. Note position marking on compression rings, and install with markings pointing up. See Fig. 10.

2) Lightly lubricate rings, and using installation tool (5106), press piston into proper bore. Make sure that stamped arrow on top of piston is pointing toward the front of engine. This will introduce a clearance between the big end bearing and the crankshaft journal.

3) This clearance should be positioned behind for cylinders 1, 2, and 3, and in front for cylinders 4, 5, and 6. Install bearing cap, and tighten to 33-37 ft. lbs. (45-50 N.m).

### PISTONS & LINERS

1) Pistons and liners are available only as matched sets. Pistons are classified by diameter in 3 categories. Marking on piston top is either "A", "B", or "C", and corresponds to liners marked "1", "2", or "3" respectively.

2) The liners are marked in the recesses at the top of the liner. Pistons and piston pins are also classified by diameters, with blue, red, and white markings being used instead of numbers for proper matching.

### PISTON AND LINER DIAMETERS

Piston Designation	In. (mm)
"A" .....	3.5815-3.5819 (90.97-90.98)
"B" .....	3.5819-3.5823 (90.98-90.99)
"C" .....	3.5823-3.5827 (90.99-91.00)

Liner Designation	In. (mm)
"1" (for piston "A") .....	3.5827-3.5831 (91.00-91.01)
"2" (for piston "B") .....	3.5831-3.5835 (91.01-91.02)
"3" (for piston "C") .....	3.5835-3.5839 (91.02-91.03)

3) Measure piston diameter at right angles to pin bore. Take measurements .236" (6.0 mm) above lower edge. With an inside dial indicator, check cylinder liner taper, wear, and out-of-round.

4) Take measurement for maximum wear immediately below top dead center, and at a right angle to engine center line. Take measurement for minimum wear at bottom dead center of piston stroke.

5) To determine piston-to-cylinder clearance, subtract piston diameter from maximum and minimum bore diameters. Do not remove pistons from connecting rods, unless piston and liner replacement is necessary.

6) If liner is to be removed for cleaning or inspection, mark liner and block with colored pen. Do not damage gasket surface. Remove liner holders and pull up liners.

7) When installing liners, be sure contact surfaces on block and liner are clean and without defect. Install No. 1 liner first (without shims) using previous pen markings for alignment.

8) Tighten liner by hand, using two liner holders (5093). Using dial indicator, measure liner height above block at three points.

9) Largest measurement should not exceed smallest measurement by more than .002" (.05 mm). Liner should be as close to .0091" (.23 mm) above block face as possible. Use correct shims to achieve dimension:

### LINER SHIM THICKNESSES <sup>1</sup>

Color	In. (mm)
Blue .....	.0028-.0041 (.070-.105)
White .....	.0033-.0047 (.085-.120)
Red .....	.0041-.0055 (.105-.140)
Yellow .....	.0051-.0065 (.130-.165)

<sup>1</sup> — Use same thickness shims for all liners.

10) Install shims with color marking up and positioned as shown in Fig. 11. Inner tabs on shims should be in liner groove.

Fig. 11: Positioning Shims on Liners

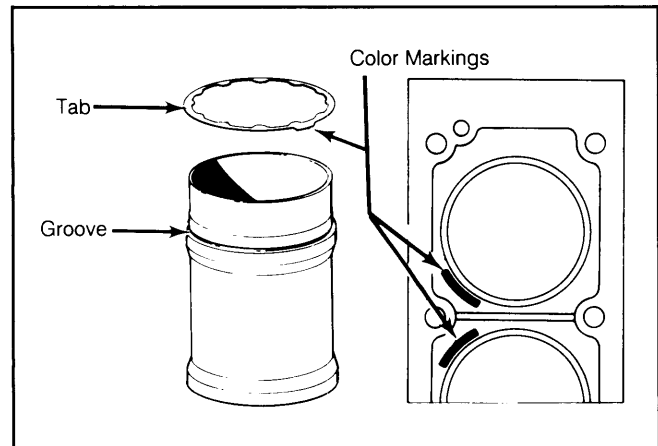

11) Tabs on shim should engage groove on liner.

11) After shimming, install four liner holders (5093) for each bank. Again measure each liner at three points. Largest and smallest dimensions should be within .002" (.05 mm).

12) Measure three liners at points shown in Fig. 12. Difference in measurements between points "1" and "2" and between "3" and "4" should not exceed .0016" (.04 mm). If height difference is excessive, change shims.

Fig. 12: Checking Liner Height Above Block Face

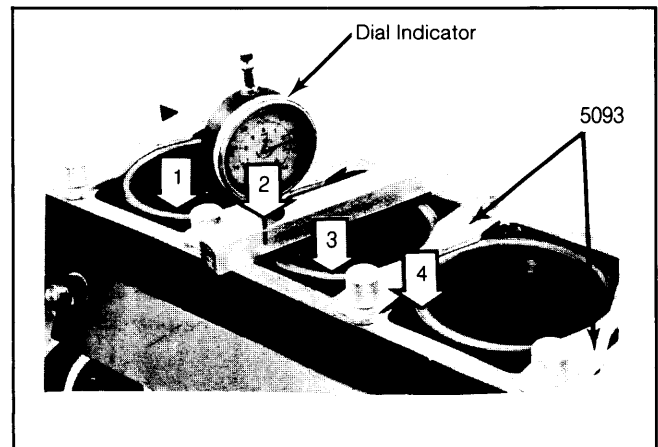

Liner should protrude .0063-.0091" (.16-.23 mm) above block.

## B28F V6 (Cont.)

### CRANKSHAFT MAIN & CONNECTING ROD BEARINGS

#### MAIN AND CONNECTING ROD BEARINGS

##### Removal

1) Remove oil pan, lower crankcase, cylinder heads, clutch, drive plate or flywheel, spacer (automatic transmission) and input shaft pilot bearing (manual transmission). Remove seal holder and use drift (5107) to press out seal. Press new seal in flush with retainer.

2) Check main bearing cap markings (marked 1 through 4, from rear-to-front). Remove main bearing retainers and caps. Remove upper and lower thrust bearings and lift out crankshaft. Remove main bearings from block and caps.

**NOTE:** Thrust bearing is located on flywheel end of crankshaft.

##### Installation

1) After inspecting crankshaft and measuring journals for wear, position oiled main bearings with oil holes to the engine block. Carefully set crankshaft into place.

2) Oil and install thrust bearings with notched ends in the engine block groove. Oil and install unnotched thrust bearings on the crankshaft.

3) Noting that cap identification number faces front of engine, lubricate bearing shell and position in bearing cap. Install bearing cap and bearing retainers (5096).

4) Using a dial indicator, measure crankshaft end play and install thrust washers to bring end play to .0028-.0106" (.07-.27 mm).

5) Oil remaining bearing shells, place in caps, and install, noting that cap number points toward front of engine.

6) Install main bearing retainer on rear main cap, and one nut on each remaining bearing cap to keep them in place until ready to install lower crankcase. Install lower crankcase and torque main caps. See Lower Crankcase.

### ENGINE OILING

#### CRANKCASE CAPACITY

6.8 quarts (6.5L) with oil filter change, and 6.3 quarts (6.0L) without filter change.

#### OIL FILTER

Full-flow type, disposable, spin-on element.

#### OIL PRESSURE

With engine warm and a new filter installed, minimum 26 psi (2 kg/cm<sup>2</sup>) @ 900 RPM, and 58 psi (4 kg/cm<sup>2</sup>) @ 3000 RPM.

#### ENGINE OILING SYSTEM

Engine utilizes a force-feed lubrication system. Oil moves from oil pan through strainer to oil pump and

full-flow oil filter mounted outside of engine block assembly. Oil is pressure fed from filter to drilled galleries in block.

Lubricant moves under pressure to main bearings, which are drilled to pass oil on to connecting rod and camshaft bearings, upward in block to rocker arm shafts.

Excess or run-off oil drains back down into oil pan through drain holes in cylinder head. Cylinder walls and piston rings are lubricated by splash from connecting rods.

#### OIL PUMP SPECIFICATIONS

Dimension Application	In. (mm)
Gear Width, Class 1 .... 1.2167-1.2175	(30.905-30.925)
Gear Width, Class 2 .... 1.2175-1.2183	(30.925-30.945)
Housing Width, Class 1 .....	1.2185-1.2195 (30.950-30.975)
Housing Width, Class 2 .....	1.2195-1.2209 (30.975-31.010)
End Play .....	.0010-.0033 (.025-.084)
Clearance Tooth-to-Housing .....	<sup>1</sup> .0043-.0073 (.110-.185)
Backlash .....	<sup>1</sup> .007-.011 (.17-.27)
Bearing Clearance, Driving Shaft .....	.0006-.0021 (.015-.053)
Bearing Clearance, Trailing Shaft .....	.0006-.0021 (.015-.053)
Relief Valve Spring Length, No Load .....	3.52 (89.5)

<sup>1</sup> — Excluding bearing clearance.

#### OIL PUMP

The oil pump is stocked as a complete unit (housing cover with impeller, and relief valve). Inspect housing, cover, and gears for damage and wear. Replace if necessary.

##### Removal

Remove both valve covers, crankshaft pulley, and timing gear cover. Remove oil pump drive sprocket and chain. Loosen the 4 retaining bolts, and lift out oil pump and gears.

##### Installation

Place gears on shaft, and oil the housing, gears and shaft. Install pump assembly, ensuring pump gears and shafts are centered in housing before tightening bolts. Install pump drive sprocket and chain. Install remaining components in reverse of removal order.

### ENGINE COOLING

#### THERMOSTAT

Wax-type. Begins to open at 176-181°F (80-83°C); fully open at 194-201°F (90-94°C). Marking, 180°F (82°C).

#### COOLING SYSTEM CAPACITY

11.5 qts. (10.9L).

# Volvo Engines

## B28F V6 (Cont.)

### RADIATOR CAP

9-12 psi (0.6-0.8 kg/cm<sup>2</sup>).

### WATER PUMP

#### Removal & Installation

1) Drain coolant from both sides of block. Remove intake manifold, 2 expansion tank hoses from radiator, upper radiator hose and automatic transmission oil cooler pipes. Remove fan shroud, radiator and fan.

2) Remove hoses from pump to block. Remove fan belts, water pump pulley, and remaining hose clamps. Remove senders from water pump, and pump from block. Remove cover and thermostat and cover from body. Install in reverse order.

### TIGHTENING SPECIFICATIONS

Application	Ft. Lbs. (N.m)
Camshaft Center Bolt .....	51-59 (69-80)
Crankshaft Pulley Nut .....	118-132 (160-180)
Cylinder Head Bolts	
Step 1 .....	7 (10)
Step 2 .....	22 (30)
Step 3 .....	1 44 (60)
Connecting Rod Cap Nuts .....	33-37 (45-50)
Exhaust Manifold Bolts .....	7-11 (10-15)
Flywheel Bolts .....	33-37 (45-50)
Intake Manifold Bolts .....	7-11 (10-15)
Main Bearing Nuts .....	2 22-25 (30-34)
Lower Crankcase Bolts .....	11-15 (15-20)
Transmission-to-Engine .....	30-36 (41-49)

1 — Retorque using protector after Step 3, once engine is completed.

2 — Tighten to spec. given PLUS an additional 75°.

## ENGINE SPECIFICATIONS

### GENERAL SPECIFICATIONS

Year	Displacement		Fuel System	HP@RPM	Torque Ft. Lbs.@RPM	Compr. Ratio	Bore		Stroke	
	Cu. In.	cc					In.	mm	In.	mm
1982	174	2849	Fuel Inj.	130@5500	153@2750	8.8:1	3.53	91.0	2.87	73.0

### VALVES

Engine Size & Valve	Head Diam. In. (mm)	Face Angle	Seat Angle	Seat Width In. (mm)	Stem Diameter In. (mm) 1	Stem Clearance In. (mm) 1	Valve Lift In. (mm)
2849 cc Intake	1.73 (44)	29.5°	29.5°	.067-.083 (1.7-2.1)	.3140-.3146 (7.97-7.99)	.0004-.0018 (.010-.046)	.2364 (6.004)
Exhaust	1.46 (37)	30°	30°	.079-.094 (2.0-2.4)	.3136-.3142 (7.96-7.98)	.0008-.0022 (.020-.056)	.2364 (6.004)

1 — Stem diameter gets larger from head of valve toward stem, where above measurement is taken.

### PISTONS, PINS, RINGS

Engine	PISTONS	PINS		RINGS		
	Clearance In. (mm)	Piston Fit In. (mm)	Rod Fit In. (mm)	Ring No.	End Gap In. (mm)	Side Clearance In. (mm)
2849 cc	.0008-.0016 (.020-.040)	.0004-.0006 (.010-.015)	.0008-.0016 (.020-.041)	Comp. 1	.016-.022 (.40-.55)	.0018-.0029 (.045-.074)
				Comp. 2	.016-.022 (.40-.55)	.0010-.0021 (.025-.054)
				Oil	.015-.055 (.38-1.4)	.0004-.0092 (.009-.233)

### CRANKSHAFT MAIN & CONNECTING ROD BEARINGS

Engine	MAIN BEARINGS				CONNECTING ROD BEARINGS		
	Journal Diam. In. (mm)	Clearance In. (mm)	Thrust Bearing	Crankshaft End Play In. (mm)	Journal Diam. In. (mm)	Clearance In. (mm)	Side Play In. (mm)
2849 cc	2.7576-2.7583 (70.043-70.062)	.0015-.0035 (.038-.088)	.....	.0028-.0106 (.070-.270)	2.0578-2.0585 (52.267-52.286)	.0012-.0031 (.030-.080)	.008-.015 (.20-.38)

# Volvo Engines

6-387

## B28F V6 (Cont.)

### ENGINE SPECIFICATIONS (Cont.)

#### VALVE SPRINGS

Engine	Free Length In. (mm)	PRESSURE Lbs. @ In. (Kg @ mm)	
		Valve Closed	Valve Open
2849 cc	1.854 (47.1)	52-60@1.57 (24-27@40)	132-152@1.181 (61-69@30)

#### CAMSHAFT

Engine	Journal Diam. In. (mm)	Clearance In. (mm)	Lobe Lift In. (mm)
2849 cc Front	1.5921-1.5931 (40.440-40.465)	.0014-.0033 (.035-.085)	.....
2nd	1.6157-1.6173 (41.040-41.065)		
3rd	1.6394-1.6404 (41.640-41.665)		
4th	1.6630-1.6640 (42.240-42.265)		

<sup>1</sup> — End play should be .0028-.0057" (.070-.144 mm).