

JETTA, QUANTUM, RABBIT, RABBIT PICKUP & SCIROCCO 4-CYLINDER

ENGINE CODING

ENGINE IDENTIFICATION

Engine identification number is stamped on left side of engine block near ignition distributor.

ENGINE IDENTIFICATION

Application	Code
Quantum	WT
All Others	EN

ENGINE, MANIFOLDS & CYLINDER HEAD

ENGINE

NOTE: On all except Quantum, engine and transmission must be LOWERED out of vehicle as an assembly.

Removal (Quantum)

1) Disconnect battery ground. Set heater temperature control to warm position. Open radiator cap. Remove power steering pump attaching bolts. Remove drive belt and place power steering pump to the side leaving hoses connected.

NOTE: Never drain coolant while engine is hot. Doing so could cause engine block or cylinder head to warp.

2) Drain engine coolant and remove hose from coolant outlet on head. Disconnect electrical connectors from thermo-time switch, alternator and control pressure regulator. Disconnect vacuum hoses from ignition distributor. Remove bolts and place control pressure regulator aside with fuel lines connected.

3) Disconnect wires from radiator fan switch and fan. Loosen radiator bracket bolt and remove radiator assembly complete with air duct and fan. Remove clip on clutch cable and unhook cable. Remove nut on left engine mount. Disconnect wire for Hall sending unit at distributor.

4) Disconnect coil wire, wire from ignition distributor, wire from coolant temperature sender and wire for oxygen sensor thermo-switch. Disconnect coolant hoses. Disconnect electrical wires for cold start valve, frequency valve and oxygen sensor. Remove charcoal filter valve from air duct and remove air duct.

5) Remove preheater hose and cold start valve (with fuel line connected). Disconnect vacuum hose for ignition distributor from intake manifold. Remove accelerator cable, crankcase breather hose and brake booster hose. Remove electrical connector from auxiliary air regulator.

6) Pull out the injectors and protect with caps (leave fuel lines connected). Remove fuel distributor with air filter housing and lay aside (leave fuel lines connected). Lay aside cold start valve, control pressure regulator and fuel injectors (leave all fuel lines connected).

7) On models without air conditioning, remove front engine mount. On all models, remove exhaust pipe from manifold. Disconnect electrical wiring from starter. Remove nuts from right engine mount. Remove starter

bolts. Remove lower engine-to-transmission bolts and flywheel cover plate.

8) On models with automatic transmission, remove starter. Remove 3 torque converter mounting bolts. On all models, support transmission with special support tool (VW 785/1B). On models with air conditioning, remove front engine mount. Loosen nuts on outer half of crankshaft pulley and remove drive belt.

9) Remove upper air conditioning compressor mounting bracket bolts. Remove 3 lower compressor mounting bracket bolts. Remove compressor with bracket and place aside with wiring connected. Remove throttle valve housing, auxiliary air regulator and horn bracket. Remove condenser with hoses and lay aside.

10) On all models, attach engine sling (US 1105) to engine and lift engine until all engine mounts are free. Remove right engine mount. Tension transmission supporting tool again. Remove upper engine-to-transmission bolts.

11) Separate engine from transmission. Lift and turn engine to remove from vehicle. On automatic transmissions, secure torque converter to transmission to keep it from falling out.

Installation

To install engine, reverse removal procedures using care to observe all tightening specifications. Engine mounts must be properly aligned and free of tension before tightening.

Removal (All Except Quantum)

1) Disconnect battery cables at battery. Loosen fuel filler cap to relieve tank pressure. Remove rubber duct connecting throttle valve assembly to mixture control unit. Drain engine coolant by removing hose from thermostat flange.

NOTE: Never drain coolant while engine is hot. Doing so could cause engine block or cylinder head to warp.

2) Disconnect radiator fan motor and thermostat. Remove radiator with fan motor and ducts. On air conditioned vehicles, remove air conditioner compressor and tie aside without disconnecting hoses.

3) On all models, disconnect the following electrical connectors: Alternator, thermostat, oil pressure switch, warm-up regulator, coolant temperature sensor, coil and condenser wires, cold start valve, auxiliary air regulator and starter solenoid harness.

4) Remove intake air pre-heating duct. Remove injectors. Remove fuel lines for cold start valve and warm-up regulator. Disconnect remaining fuel, coolant, emission control and vacuum lines and position out of the way. Have a container ready to catch leaking fuel in case system is still under pressure.

5) Disconnect and remove accelerator linkage from engine. Disconnect speedometer cable and ground cable from transmission. Detach selector cable and bracket on automatic transmission models. Detach the clutch cable from the clutch operating lever on manual transmission models.

6) On all models, disconnect starter wires and back-up light switch. Raise vehicle. Remove exhaust flex-pipe nuts or spring clip. On manual transmission models, remove shift lever from shift linkage. On all models,

Volkswagen Engines

JETTA, QUANTUM, RABBIT, RABBIT PICKUP & SCIROCCO 4-CYLINDER (Cont.)

remove the starter. Disconnect the drive shafts from the drive flanges.

7) Remove horn and place out of the way. Remove engine front mount. Lower vehicle and remove axle nuts. Raise vehicle and disconnect lower ball joints from bearing housings. Remove drive shaft while holding strut assembly away from vehicle.

8) Reconnect ball joints and lower vehicle onto wheels. Attach lifting sling (US 1105) to engine and lift slightly. Remove complete rear mount. Remove right front wheel. On manual transmission models, remove relay shaft and gearshift lever rods.

9) On all models, remove bolts holding side mounts to body and lower engine and transmission assembly to the dolly. Raise vehicle to clear engine and remove assembly from beneath vehicle.

Installation

To install, reverse removal procedure using caution to observe all tightening specifications. Engine mounts must be properly aligned and free of tension before tightening.

CYLINDER HEAD & MANIFOLDS

Removal

1) Disconnect duct connecting throttle valve housing to mixture control unit. Remove radiator cap. Remove thermostat housing from water pump. Remove thermostat and drain cooling system.

NOTE: Never drain coolant while engine is hot. Doing so could cause engine block or cylinder head to warp.

2) Remove camshaft drive belt. Remove injectors from manifold tubes. Disconnect all hoses, cables and wires attached to throttle valve housing and intake air distributor. Disconnect exhaust pipe.

3) Remove nuts and bolts that hold exhaust manifold and intake manifold (air intake distributor) to cylinder head. Remove manifolds. Remove any screws, bolts or clips attaching air conditioning components to cylinder head (if equipped).

4) Remove upper alternator mounting bolt and adjusting bracket. Disconnect all coolant hoses. Disconnect temperature gauge wire. Remove spark plug wires and spark plugs. Remove the wire from the oil pressure sending unit.

5) Remove valve cover. Remove head bolts in reverse order of installation. Remove cylinder head. If head is stuck, pry off with a block of wood placed in each outboard exhaust port.

Installation

To install, reverse removal procedure. Make sure head gasket is positioned with "OBEN" mark facing up. Tighten head bolts in sequence and according to step outlined in table.

CYLINDER HEAD TIGHTENING STEPS

Application	Ft. Lbs. (N.m)
Step No. 1	29 (40)
Step No. 2	44 (60)
Step No. 3	54 (75) Plus 1/4 Turn

NOTE: Polygon (12 point) socket head bolts are set to final torque while cold and do not need to be retightened when hot. Tighten in sequence to 54 ft. lbs. (75 N.m) plus an additional 1/4 turn.

Fig. 1: Cylinder Head Tightening Sequence

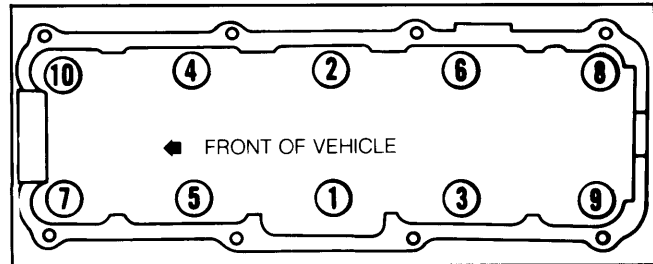

Loosen in reverse order.

CAMSHAFT

TIMING BELT

NOTE: Sprockets DO NOT have to be removed to replace camshaft drive belt.

Removal

Remove alternator belt, water pump pulley, and upper and lower drive belt covers. If equipped, remove air conditioning compressor drive belt. Loosen belt tensioner, and work belt off sprockets toward front of engine.

Fig. 2: Intermediate Shaft Alignment

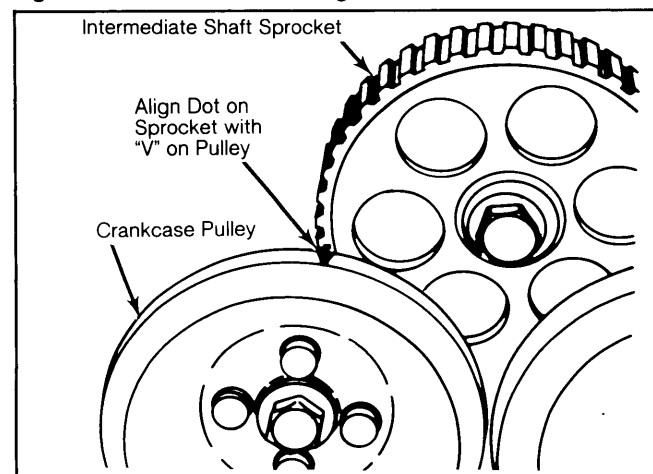

Rotate intermediate shaft and crankshaft to align marks.

Installation

1) Rotate camshaft sprocket until index punch mark on camshaft sprocket is lined up with top surface of valve cover mounting flange on spark plug side of head. Rotate crankshaft and intermediate shaft until index punch mark on intermediate shaft sprocket aligns with "V" notch on crankshaft pulley.

2) Use care not to move any sprocket. Fit belt on bottom first and then at top. There should be no slack

JETTA, QUANTUM, RABBIT, RABBIT PICKUP & SCIROCCO 4-CYLINDER (Cont.)

between sprockets. Tighten tensioner so belt can just be twisted 90° halfway between camshaft and intermediate sprockets. Tighten adjuster lock nut and reverse removal procedure for remaining components.

CAMSHAFT

Removal

1) Remove camshaft cover. Loosen and remove bearing caps in following sequence: 5, 1, and 3. Then loosen bearing caps 2 and 4 diagonally. Bearing caps are numbered front to rear.

2) Check camshaft end play. Remove camshaft and lift out cam followers. Install camshaft using only bearing caps 1 and 5. Fit dial indicator so tip of gauge touches front of camshaft. Pry camshaft back and forth. Reading should not exceed .006" (.150 mm). If end play is beyond limits, replace either camshaft or cylinder head.

3) Check camshaft runout. Fit dial indicator so gauge pin is against camshaft center journal. Turn camshaft and record runout range. Runout must not exceed .0004" (.010 mm). Replace camshaft as necessary.

4) Inspect camshaft lobes for wear. Worn lobes usually indicate lack of lubrication. Check engine oiling passages to make sure they are not restricted. If worn, replace camshafts and discs.

5) Inspect cam followers for signs of seizure or lack of lubrication. If any aluminum particles from head are found on cam followers, replace followers. Cylinder head must be replaced if any follower bores are worn or excessively rough.

Installation

1) Lightly lube cam follower bores, then fit followers in their original bores. Install adjusting discs. Place camshaft on cylinder head. Loosely attach No. 2 and No. 4 bearing caps.

2) Gradually tighten caps. Fit No. 5 and No. 3 bearing caps. Install new oil seal in front of camshaft. Install No. 1 bearing cap. Make sure all caps are torqued to proper specifications.

VALVE TIMING

1) With timing belt removed as previously described, rotate crankshaft and intermediate shaft until

index mark (punch mark) on intermediate shaft is positioned in "V" notch on crankshaft pulley. See Fig. 2.

2) This is firing point of No. 1 cylinder. Next, turn camshaft until timing mark on rear of camshaft sprocket is in line with top of cylinder head cover flange. See Fig. 3. Replace timing belt.

VALVES

VALVE ARRANGEMENT

E-I-E-I-I-E-I-E (Front-to-rear).

VALVE GUIDE SERVICING

1) Clean valve guides before making measurements. To measure guide, attach a mounting device with a dial gauge (VW689/1) to mounting surface of cylinder head. Insert a new valve until end of stem is flush with end of valve guide.

2) Rock valve head against dial indicator and check amount of rock recorded. Maximum allowable rock is .039" (1.0 mm) for intake valves and .051" (1.30 mm) for exhaust valves. Proper valve guide diameter is .315"-.316" (8.01-8.04 mm).

3) Use a press and adaptor (10-206) to remove and install valve guides. To remove guides, press out from combustion chamber side of head.

4) Coat new valve guides with engine oil. Press new guides into cold head from camshaft side. Make sure shoulder of guide meets firmly with top of cylinder head. Ream guides to uniform inside diameter.

NOTE: Do not use more than 1 ton pressure once guide shoulder is seated or shoulder may break.

VALVE SPRINGS

NOTE: Although normal maintenance on valve system is performed with head removed, it is possible to replace stem seals, keepers, retainers or broken springs with cylinder head installed.

Removal (Head Installed)

With camshaft and tappets removed, turn crankshaft until piston of cylinder being worked on is at BDC. Apply steady air pressure of at least 85 psi through spark plug hole adapter to keep valves seated. Compress spring with tool (VW 541) and remove valve keepers. Remove and replace damaged or worn parts.

Removal (Head Removed)

With camshaft and tappets removed, use compressor (VW 541) to depress retainer and remove keepers. Take out retainer and springs.

Installation

1) Before installation, check springs on spring tester and inspect for cracks or distortion. Lower edge of valve spring retainer should be chamfered to prevent valve stem scoring.

2) If necessary, grind a chamfer using stone or other tool. To install, reverse removal procedure. When installing the springs, make sure closely spaced coils of outer springs are against spring seats.

Fig. 3: Camshaft Sprocket Positioning

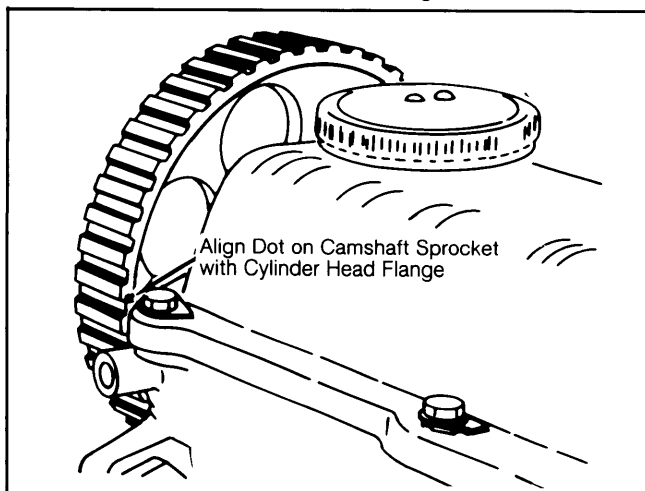

Align dot on sprocket with cylinder head flange.

Volkswagen Engines

JETTA, QUANTUM, RABBIT, RABBIT PICKUP & SCIROCCO 4-CYLINDER (Cont.)

VALVE STEM OIL SEALS

With tappet, adjuster pad, keepers, springs, and spring seats removed, extract valve stem oil seal. When installing new seal, first position protective plastic sleeve on valve stem, lubricate seal, and use a mandrel (10-204) to push seal onto valve guide.

VALVE CLEARANCE ADJUSTMENT

1) Adjust valves with engine at normal operating temperature. Clearance adjustments are to be checked and made according to firing order. Using a wrench on the crankshaft pulley bolt, turn clockwise to bring No. 1 piston to TDC (cam lobes pointing up).

Fig. 4: Assembled View of Valve and Camshaft

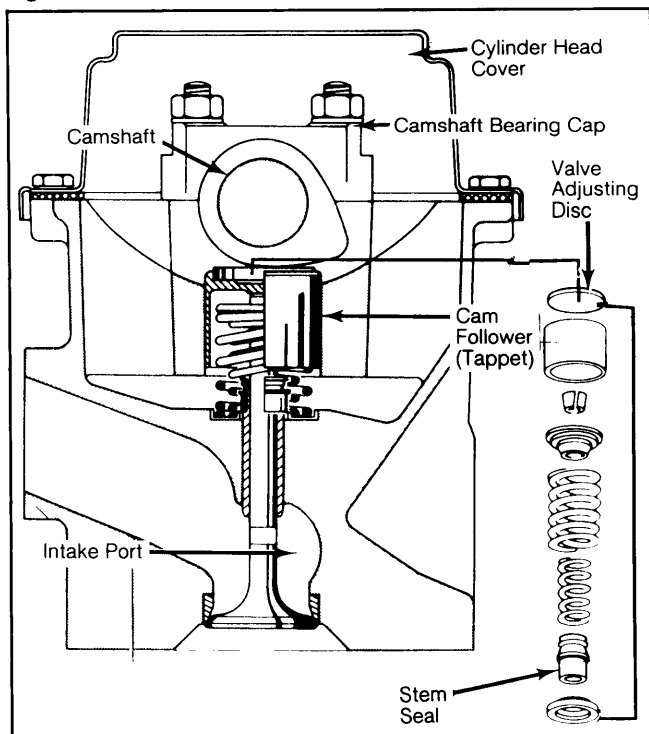

2) Determine valve clearance by inserting a feeler gauge between cam lobe heel and adjusting disc. Rotate crankshaft pulley 180° at a time, and check cylinder Nos. 3, 4 and 2, consecutively.

3) If necessary, adjust to specifications by installing thicker or thinner adjusting discs. Discs are available in 26 different thicknesses in increments of .0019" (.050 mm). Disc thickness is stamped on bottom, and ranges from .1181" (3.00 mm) to .1673" (4.25 mm).

4) To install, press cam follower down with follower depressing tool (VW 546). Remove old disc with special pliers (VW 208), and insert new disc with stamped thickness marking toward cam follower.

NOTE: Cold settings are given for reference, as initial settings to be used during cylinder head rework. Final adjustments are made at normal operating temperature, and should be rechecked after approximately 1000 miles of operation.

VALVE CLEARANCE SPECIFICATIONS

Application	In. (mm)
Intake	
Hot008-.012 (.20-.30)
Cold006-.010 (.15-.25)
Exhaust	
Hot016-.020 (.40-.50)
Cold014-.018 (.35-.45)

PISTONS, PINS & RINGS

OIL PAN

NOTE: Removal and installation procedure not available for Quantum.

Removal & Installation

1) Drain oil, remove bolts and remove oil pan. Remove nuts holding engine mounts on subframe and bolts holding subframe to body. Pull subframe downward to separate engine mounts and body.

2) Drain oil, remove mounting bolts and remove oil pan. To install, reverse removal procedure. Make sure gasket surfaces are clean before installing new gaskets.

PISTON & ROD ASSEMBLY

NOTE: Piston and rod assemblies can be removed with engine in vehicle. Manufacturer recommends engine removal for extensive overhaul work.

Removal

1) Mark cylinder number on crown of each piston. If necessary, mark arrows pointing toward front of block on piston crowns. Remove rod cap bolts and push piston out top of cylinder. Use wooden hammer handle for this operation.

2) If a ridge at top of cylinder prevents piston removal, use a ridge reamer to cut down the ridge. DO NOT force piston out of cylinder. Mark connecting rods and bearing caps for proper reinstallation.

Installation

1) Turn crankshaft so No. 1 journal is at BDC. Install piston connecting rod assembly until ring compressor contacts block. Use a wood hammer handle to push piston into cylinder. Install No. 4 piston and rod assembly.

2) Ensure tabs on bearing halves engage notch in rod and cap. Install and tighten caps on rods 1 and 4. Turn crankshaft 180° and install No. 2 and 3 rod assemblies and rod caps.

PISTON PINS

Removal

Use needle-nosed pliers to remove pin circlips. Press out pin and remove piston from rod. For installation purposes, note direction piston is fitted to rod.

Installation

1) Check pin fit in each piston. Piston pin must be thumb-push fit in piston. If correct fit is not obtained, replace both pin and piston.

JETTA, QUANTUM, RABBIT, RABBIT PICKUP & SCIROCCO 4-CYLINDER (Cont.)

2) Check pin fit in connecting rod. Wear limit is .0016" (.040 mm). Rebush connecting rod and hone bushing to obtain correct clearance.

NOTE: If pin is too tight, heat piston to approximately 140°F (60°C) in an oil bath.

FITTING PISTONS

1) Measure cylinder at 3 points: 3/8" (10 mm) from top and bottom, and at center of bore. Take measurements in line with, and at 90° to thrust face. Maximum cylinder taper or out-of-round is .0016" (.040 mm) beyond standard dimensions. If excessive, cylinder re boring and oversize pistons are necessary.

Fig. 5: Codes Stamped on Piston Head

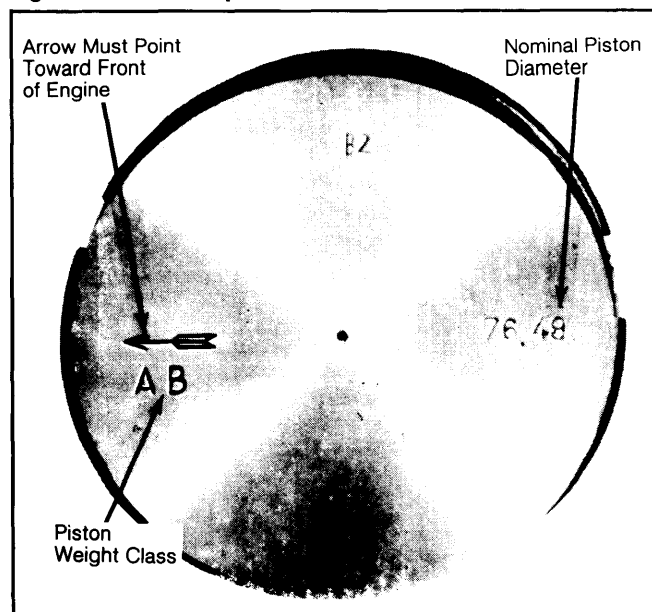
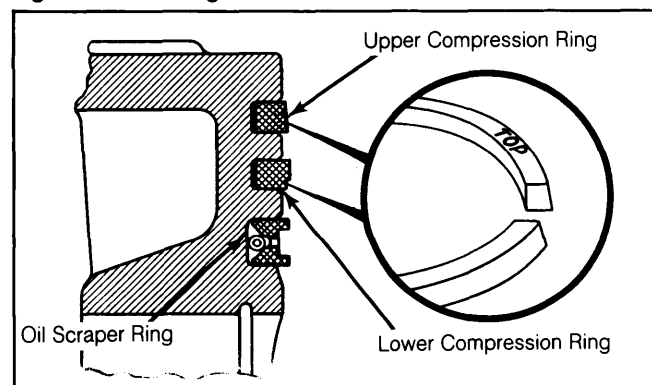

Fig. 6: Piston Ring Installation



Word TOP must face piston crown.

2) Measure pistons at .63" (16.0 mm) from bottom of piston skirt (measuring 90° to pin bore). Combining this measurement with measurement of corresponding cylinder bore, note piston-to-cylinder clearance. If this exceeds .0028" (.070 mm), oversize pistons must be installed.

3) Place rings squarely in cylinder bore about .6" (15 mm) down from top edge and measure end gap. Install rings on piston and measure side clearance. Position ring gaps 120° offset to each other (start with oil ring gap directly to the rear). Ensure stamp mark "TOP" on rings is facing upward.

CRANKSHAFT MAIN & CONNECTING ROD BEARINGS

MAIN & CONNECTING ROD BEARINGS

1) Push crankshaft toward one end and measure crankshaft end play at No. 3 (thrust) bearing. Main bearing caps are stamped "1" to "5" (front to rear), and must be returned to original positions upon reassembly. Measure end play (side play) of connecting rods.

2) Remove all bearing caps and check bearing clearance using Plastigage. Measure crankshaft journals with a micrometer to determine journal out-of-round and taper. The maximum allowable wear is .0012" (.030 mm).

3) Install main bearing inserts with oil groove in the engine block, making sure anti-rotation tabs engage in saddle notches. Lubricate new bearings, place crankshaft in block, and install lower main shells and caps in proper order.

CRANKSHAFT JOURNAL DIAMETERS

Size	Main Bearing In. (mm) ¹	Rod Bearing In. (mm) ¹
Standard	2.25 (53.97)	1.810 (45.97)
1st US	2.115 (53.72)	1.800 (45.72)
2nd US	2.105 (53.47)	1.790 (45.47)
3rd US	2.095 (53.22)	1.780 (45.22)

¹ — Journal diameter is ± .0004" (.010 mm).

REAR MAIN BEARING OIL SEAL

NOTE: Rear main bearing oil seal may be replaced with engine in vehicle. Transmission and flywheel must be removed.

Fig. 7: Using Special Tool to Install Rear Main Oil Seal

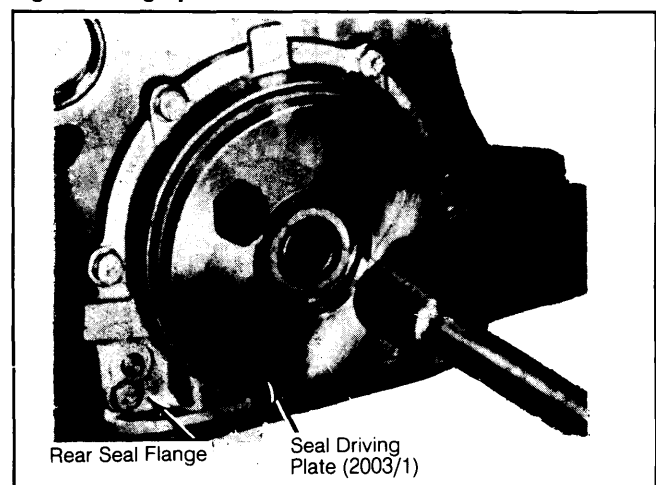

Volkswagen Engines

JETTA, QUANTUM, RABBIT, RABBIT PICKUP & SCIROCCO 4-CYLINDER (Cont.)

Removal

Insert a large screwdriver between crankshaft flywheel flange and inside lip of oil seal. Pry out old seal.

Installation

Install seal guide sleeve (2003/2A or equivalent) over crankshaft flange. Start new seal over guide sleeve, and into recess in seal carrier. Remove guide sleeve and bolt seal driving plate (2003/1 or equivalent) to flywheel mounting flange. Tighten bolts evenly to bring seal flush with carrier.

FRONT MAIN BEARING OIL SEAL AND INTERMEDIATE SHAFT OIL SEAL

Removal

Remove camshaft belt. Remove crankshaft sprocket. Pry seal from seal carrier, being careful not to damage carrier. Use removing tool (10-219 or equivalent) to remove seal.

Installation

Using installing tool (10-203 or equivalent), press in new seal until flush with seal carrier. If tool 10-203 was used, remove it and using aluminum part of tool, press seal in until recessed .080" (2.0 mm) in seal carrier.

NOTE: Same procedure applies to intermediate shaft oil seal except: Remove intermediate shaft sprocket. Only press new seal in until flush with seal carrier.

ENGINE OILING

CRANKCASE CAPACITY

Capacity is 4.2 quarts (4.7 quarts with filter change) on all except Quantum. On Quantum, capacity is 2.6 quarts (3.0 quarts with filter change).

OIL FILTER

Replaceable spin-on type.

NORMAL OIL PRESSURE

Minimum of 28 psi (1.97 kg/cm²) with engine at normal operating temperature.

ENGINE OILING SYSTEM

Oiling system is a pressure feed type. A gear oil pump lifts oil from pan and pressure feeds it to crankshaft journals, camshaft bearings, and intermediate shaft. Other parts of system receive oil mist or splash for lubrication.

OIL PUMP

Removal

With oil pan removed remove pump mounting bolts. Remove oil pump, leaving pickup tube attached. Separate pickup tube from pump.

Inspection

Check oil pump gear backlash. Clearance should be between .002-.008" (.05-.20 mm). If specification is exceeded, replace gears or pump. Measure the oil pump gear end play. If end play exceeds .006" (.15 mm), replace the pump.

Installation

To install, reverse removal procedure. Make sure all mating surfaces are clean before installing gaskets. Oil pump drive shaft must align with distributor drive gear.

ENGINE COOLING

COOLING SYSTEM CAPACITY

Coolant capacity is 7.3 quarts (6.9L) on Rabbit Pickup and Quantum, 4.9 quarts (4.6L) on all others.

THERMOSTAT

Thermostat begins to open at 176°F (80°C), fully open at 201°F (94°C).

RADIATOR CAP

Cap opens at 17-19 psi (1.2-1.3 kg/cm²).

WATER PUMP

NOTE: The front portion of water pump (shaft, seals, bearing, and housing) can be replaced separately. To do this, camshaft drive belt and sprockets must be removed. To avoid removing drive belt, remove water pump as an assembly.

Removal

Drain coolant with engine cool. Remove alternator belt and alternator. Remove air injection pump belt (if equipped). Disconnect hoses from water pump and remove bolt holding camshaft drive belt cover to water pump. Remove water pump bolts and pump assembly.

Installation

To install, reverse removal procedure and make sure to use new "O" ring in recess in pump mounting flange.

NOTE: Do not use sealer between water pump mounting flange and engine block.

TIGHTENING SPECIFICATIONS

Application	Ft. Lbs. (N.m)
Timing Belt Tensioner Lock Nut	33 (45)
Intermediate Sprocket Bolt	¹ 59 (80)
Crankshaft Sprocket Bolt	59 (80)
Water Pump Pulley Bolts	15 (20)
Crankshaft Pulley Bolts	15 (20)
Drive Plate-to-Crankshaft Bolts	¹ 55 (75)
Connecting Rod Cap Bolts	¹ 33 (45)
Main Bearing Cap Bolts	² 48 (65)
Cylinder Head Bolts	³ 54 (75) plus 1/4 turn
Ball Joints	36 (49)
Axle Nuts	173 (235)
Manifold-to-Cylinder Head Bolts	18 (25)
Water Pump Bolts	15 (20)
¹ — Use Loctite.	
² — To check clearance, tighten to 26 ft. lbs. (45 N.m) only.	
³ — In 3 steps. See text.	

Volkswagen Engines

6-355

JETTA, QUANTUM, RABBIT, RABBIT PICKUP & SCIROCCO 4-CYLINDER (Cont.)

ENGINE SPECIFICATIONS

GENERAL SPECIFICATIONS

Year	Displacement		Fuel System	HP@RPM	Torque Ft. Lbs.@RPM	Compr. Ratio	Bore		Stroke	
	Cu. In.	cc					In.	mm	In.	mm
1982	105	1715	Fuel Inj. ¹	74@5000	90@3000	8.2:1	3.13	79.5	3.40	86.4

¹ — Some rabbit models have Carter TYF 1-Bbl. carburetor.

VALVES

Engine Size & Valve	Head Diam. In. (mm)	Face Angle	Seat Angle	Seat Width In. (mm)	Stem Diameter In. (mm)	Stem Clearance In. (mm)	Valve Lift In. (mm)
1755 cc							
Intake	1.338 (33.9)	45°	45°	.079 (2.0)	.314 (7.98)	.001-.002 (.03-.05)
Exhaust	1.220 (31.0)	45°	45°	.095 (2.4)	.313 (7.95)	.002-.003 (.05-.07)

PISTONS, PINS, RINGS

Engine	PISTONS	PINS		RINGS		
	Clearance In. (mm)	Piston Fit In. (mm)	Rod Fit In. (mm)	Ring No.	End Gap In. (mm)	Side Clearance In. (mm)
1715 cc	.0012 ¹	Push Fit	.0004-.0008 ² (.01-.02)	Comp. Oil	.012-.018 ³ (.30-.45) .010-.016 ³ (.25-.40)	.0008-.002 ⁴ (.02-.05) .0008-.002 ⁴ (.02-.05)

¹ — Wear limit .027" (.07 mm). ² — Wear limit .0015" (.04 mm). ³ — Wear limit .039" (1 mm). ⁴ — Wear limit .006 (.15 mm).

CRANKSHAFT MAIN & CONNECTING ROD BEARINGS

Engine	MAIN BEARINGS				CONNECTING ROD BEARINGS		
	Journal Diam. In. (mm)	Clearance In. (mm)	Thrust Bearing	Crankshaft End Play In. (mm)	Journal Diam. In. (mm)	Clearance In. (mm)	Side Play In. (mm)
1715 cc	2.124-2.125 (53.96-53.98)	.001-.003 ¹ (.025-.076)	No. 3	.003-.007 ² (.07-.17)	1.809-1.810 (45.96-45.98)	.0011-.0033 ³ (.028-.088)	.014 ⁴ (.37)

¹ — Wear limit .007" (.17 mm). ² — Wear limit .0015" (.37 mm). ³ — Wear limit .0047" (.12 mm). ⁴ — Wear limit indicated.

CAMSHAFT

Engine	Journal Diam. In. (mm)	Clearance In. (mm)	Lobe Lift In. (mm)
1715 cc0008-.002 ¹ (.02-.05)

¹ — End play .006" (.15 mm).

VALVE SPRINGS

Engine	Free Length In. (mm)	PRESSURE Lbs. @ In. (Kg @ mm)	
		Valve Closed	Valve Open
1715 cc Inner	46-51@.719 (21-32@18.3)
Outer	96-106@.916 (43.5-48@22.3)