

## 924 & 924 TURBO 4-CYLINDER

### ENGINE CODING

#### ENGINE IDENTIFICATION

Engine number is located on left side of crankcase next to the clutch housing. Engine number is coded as follows:

#### ENGINE IDENTIFICATION

Application	Code
924 .....	V/C
924 Turbo .....	M31/02

### ENGINE, MANIFOLDS & CYLINDER HEAD

#### ENGINE

**NOTE:** Manufacturer does not provide specific instructions for 924 Turbo.

##### Removal

1) Disconnect battery cable and remove engine protection plate. Scribe hood at hinges and remove hood. Drain cooling system, remove hoses and expansion tank. Remove fan motors with shroud and alternator cooling hose. Remove A/C compressor without disconnecting hoses and lay aside.

2) Disconnect all wiring, hoses, lines, linkage and brackets from engine. On 924 Turbo, disconnect necessary parts of turbocharger and oiling system. On all models, disconnect exhaust pipe at manifold. Support driveline at front brace with wooden block. See Fig. 1. Disconnect universal joint at steering rack.

Fig. 1: Driveline Support Block

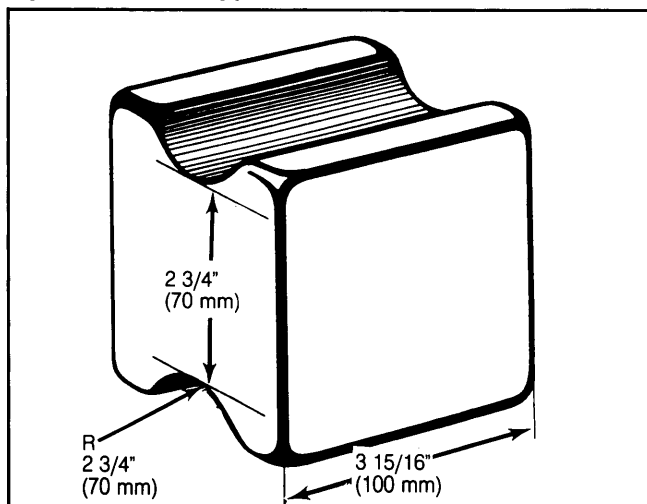

Support driveline at front brace.

3) Disconnect stabilizer bar at frame on both sides. Remove crossmember. Attach hoist and lift engine slightly. Remove bellhousing bolts and engine mounts. On vehicles equipped with automatic transmissions, remove bolts from metal and rubber damper. Lift engine carefully and turn at same time.

##### Installation

To install engine, reverse removal procedure.

### CYLINDER HEAD

#### Removal

Disconnect battery ground. Drain cooling system. Remove hoses and wiring connected to cylinder head. Remove exhaust pipe at manifold and remove camshaft timing belt and "V" belt. Remove cylinder head cover and head bolts in sequence.

#### Installation

1) To install, coat threads of cylinder head bolts with a light coat of oil. Insert head bolts Nos. 8 and 10 first to center head. Insert remaining bolts.

2) With engine cold, tighten bolts in numerical sequence shown in Fig. 2. to specifications. Mark position of bolt head and then turn each bolt an additional 1/2 turn (180°) in sequence.

3) After 60 minutes, loosen the bolts approximately 30° in reverse sequence, then tighten once again. Run the engine to operating temperature of 176°F (80°C). Let the engine cool and repeat loosening and tightening procedure.

Fig. 2: Cylinder Head Tightening Sequence

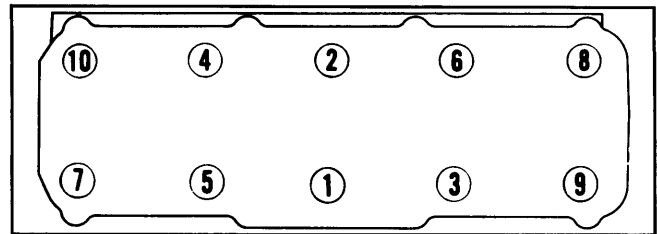

Loosen in reverse order.

### CAMSHAFT

#### FRONT MAIN BEARING OIL SEAL

##### Removal

Remove pulley bolt and using oil seal removing tool 10-221 (or equivalent), pry oil seal out of oil pump.

##### Installation

Use installing tool 2033 to install new seal.

#### TIMING BELT

##### Removal

Remove belt cover and loosen drive belt tensioner. Remove crankshaft pulley and drive belt pulley. Remove drive belt.

##### Installation

To install, reverse removal procedure. Belt must be tightened until belt can be turned 90° with thumb and index finger at a point midway between crankshaft and camshaft.

### CAMSHAFT

#### Removal

1) Remove cylinder head cover and timing belt cover. Rotate the crankshaft so marks on crankshaft pulley and camshaft sprocket are in No. 1 TDC position. Remove the camshaft sprocket, distributor and distributor drive housing.

2) Remove camshaft lubrication tube, then replace nuts (hand tight) on bearing caps 2 and 4. Remove bearing caps 5, 1 and 3. Loosen bearing caps 2 and 4 evenly in a crosswise pattern and lift out camshaft.

# Porsche Engines

## 924 & 924 TURBO 4-CYLINDER (Cont.)

### Installation

1) When installing, make sure that bearing caps are replaced in original position. Note the correct off-center position of bearing caps. To install camshaft, reverse removal procedure.

2) Place camshaft into position and install caps 2 and 4, tightening nuts in a crosswise pattern. Install caps 1, 3 and 5 and tighten all nuts to specifications. Loosen nuts 2 and 4 to install lubrication tube. Press in new camshaft oil seal.

### VALVE TIMING

1) Using either TDC mark on flywheel and casting in bell housing, or crankshaft pulley TDC mark,

**Fig. 3: Camshaft Sprocket Alignment**

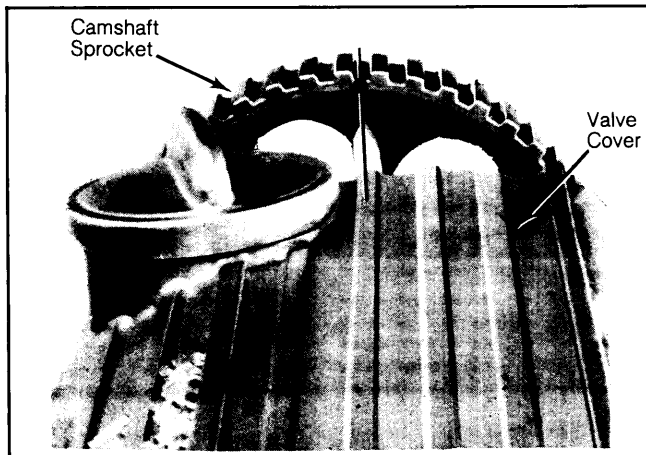

*Pulley mark and valve cover indicator aligned.*

rotate crankshaft to TDC position. Mark on rear of camshaft sprocket and indicator on cylinder head cover must be in line.

2) Make sure Woodruff key is installed and camshaft sprocket bolt is tightened properly. Install timing belt and adjust tension.

## VALVES

### VALVE ARRANGEMENT

I-E-I-E-I-E-I-E (Front-to-rear).

### VALVE GUIDE SERVICING

1) With dial indicator, measure amount of clearance between valve and guide with end of stem flush with guide. If wear exceeds limits of .032" (.80 mm) for intake, or .039" (1.00 mm) for exhaust, replace valve guides.

2) Press worn guide out from combustion chamber side. Place circlip into groove on replacement guide and press guide in from camshaft side. Replacement guides have a circlip in addition to 1 or 2 grooves.

3) Ream replacement guide by hand with dry reamer for proper clearance. Change valve spring retainer resting on head to replacement type with groove.

**NOTE:** During repairs, installed guides must have the same codes as those replaced.

**Fig. 4: Measuring Valve Guide Clearance**

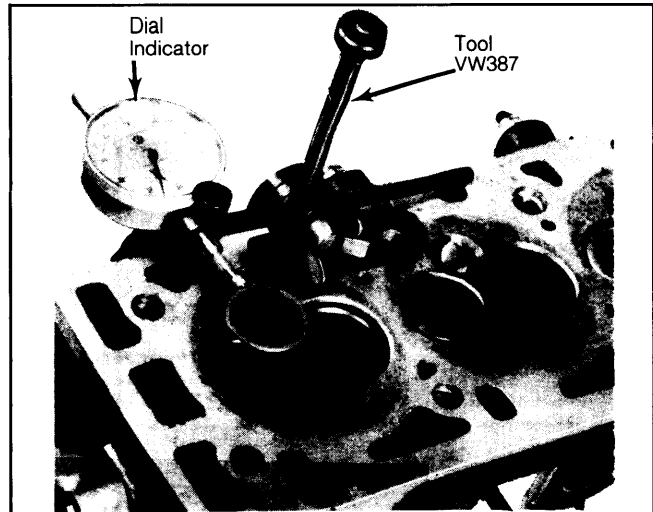

*Replace guide if limit is exceeded.*

### VALVE GUIDE IDENTIFICATION

Valve	Marking	Outside Dia. In. (mm)
Intake	No Groove	.5542 (14.079)
Exhaust	No Groove	.5538 (14.068)
Intake	1 Groove	.5622 (14.279)
Exhaust	1 Groove	.5617 (14.268)
Intake	2 Grooves	.5700 (14.479)
Exhaust	2 Grooves	.5695 (14.467)

**Fig. 5: Replacement Valve Guide and Intake Spring Retainer**

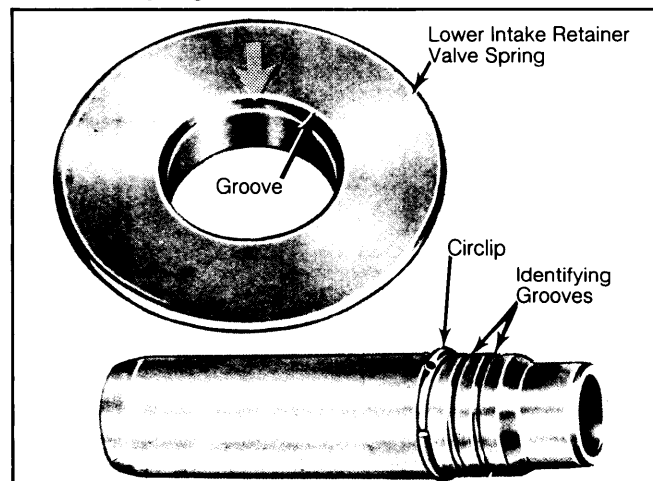

*Ream with dry reamer to proper clearance.*

### VALVE STEM OIL SEALS

**NOTE:** Valve stem oil seal may be replaced with cylinder head installed.

#### Removal

Remove spark plug on cylinder being serviced, install air hose and adapter to maintain constant pressure

## 924 & 924 TURBO 4-CYLINDER (Cont.)

in cylinder. Remove camshaft, tappets, valve stem keepers and valve spring. Remove oil seal and discard.

### Installation

To install, reverse removal procedure. Be sure plastic sleeve is installed prior to seal installation. Place sleeve on valve stem, lubricate seal and install onto valve stem.

### MECHANICAL VALVE LIFTERS

#### Removal & Installation

With camshaft removed, lift out tappet and inspect for wear or damage. Oil tappets lightly and replace in original position.

### VALVE CLEARANCE ADJUSTMENT

1) Remove cylinder head cover and turn crankshaft until cam lobes of cylinder to be adjusted are pointing upward. Check valve clearance with feeler gauge between tappet and lobe.

**Fig. 6: Checking and Adjusting Valve Clearance**

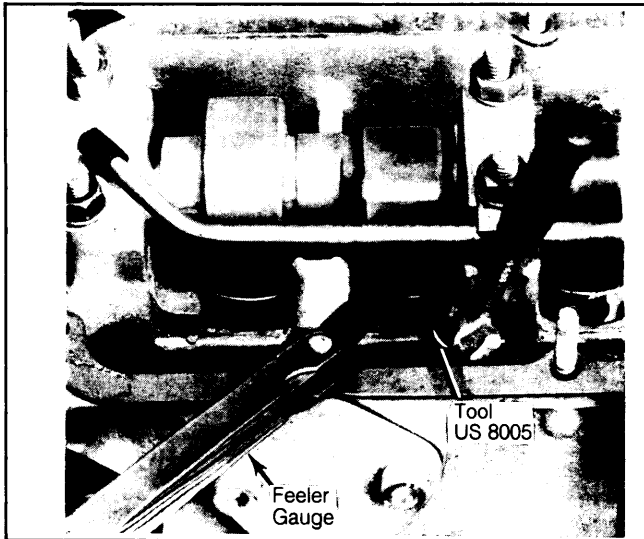

Cam lobes on valves being adjusted should point upward.

2) Basic valve clearance with engine cold (when reconditioning engine) is .004" (.10 mm) for intake valve and .016" (.40 mm) for exhaust valve. Valve clearance should be checked with engine warmed to 176°F (80°C) oil temperature. Intake valve clearance is .008" (.20 mm) and exhaust clearance is .018" (.45 mm).

3) Adjust clearance by turning screw mounted in tappet with adjusting tool (US 8005). Adjustment must be in complete turns only. One turn of screw changes clearance by .002" (.05 mm). After adjusting valve, be sure edge of tappet is in line with Green area of tool.

**Fig. 7: Valve Lifter with Adjusting Screw and Tool**

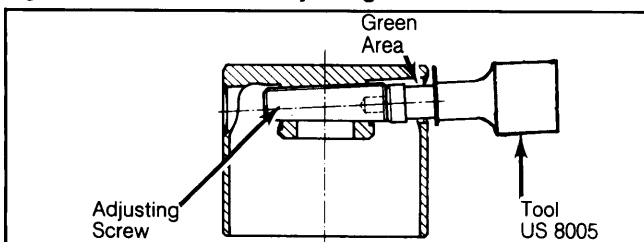

Adjust in complete turns only.

### PISTONS, PINS & RINGS

#### OIL PAN

##### Removal

Drain engine oil and loosen left engine mount slightly. Disconnect steering at crossmember and remove crossmember. Remove oil pan bolts and lower oil pan.

##### Installation

To install, reverse removal procedure and tighten pan bolts.

### PISTONS & ROD ASSEMBLY

1) Before removing connecting rods, mark rod and cap for installation in original position. Remove rod caps and carefully push piston and rod assembly out top of block.

2) On reassembly of piston and rod assembly, cast bosses on rod and cap must face pulley end of engine. Code numbers must be on same side. Using a ring compressor, install piston and rod assembly with arrow on crown of piston facing front of engine.

### FITTING PISTONS

1) Measure cylinder bore .39" (10.0 mm) down from top and up same distance from bottom, also in the center. Take 2 measurements, one in line with crankshaft and again 90° to crankshaft.

**Fig. 8: Measuring Piston Diameter at Skirt**

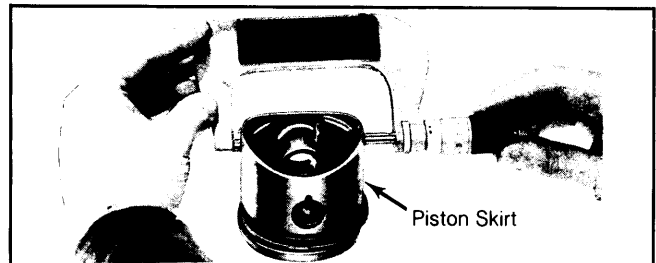

2) Measure piston .63" (16.0 mm) from bottom of skirt, 90° to pin bore. Combine measurements with those taken from cylinder bore. If piston-to-cylinder measurement exceeds .0016" (.040 mm), oversized pistons must be installed.

3) Place piston rings squarely in bottom of cylinder bore approximately .59" (15.0 mm) from surface and measure ring gap. Wear limit is .039" (1.00 mm). Measure ring side clearance in piston. Wear limit is .004" (0.10 mm). Install rings with "TOP" mark facing piston crown and gaps offset 120° from each other.

**Fig. 9: Measuring Ring Gap in Cylinder Bore**

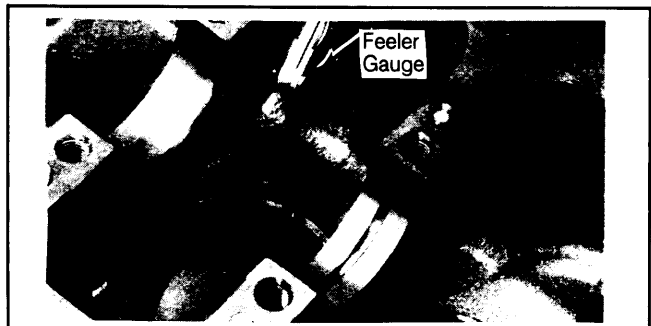

Ring must be placed squarely in bore.

# Porsche Engines

## 924 & 924 TURBO 4-CYLINDER (Cont.)

### PISTON PINS

#### Removal

Remove circlip. Using piston pin remover VW 207c, remove pins.

#### Installation

To install, reverse removal procedure. If pin is hard to install, heat piston to approximately 140°F (60°C).

**Fig. 10: Piston Pin Removal and Installation**

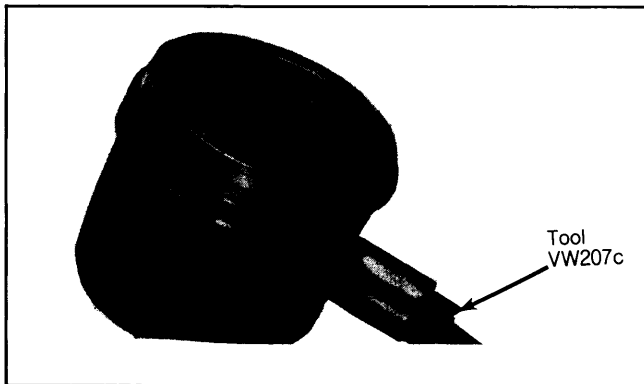

Heat piston to 140°F (60°C) to install.

### CRANKSHAFT MAIN & CONNECTING ROD BEARINGS

#### MAIN & CONNECTING ROD BEARING SERVICE

1) Push crankshaft toward one end and measure end play at No. 3 thrust bearing. Be sure main bearing caps are marked for reinstallation. Measure connecting rod side play. Remove rod and main bearing caps and check bearing clearance using Plastigage method.

**Fig. 11: Measure Crankshaft End Play as Shown**

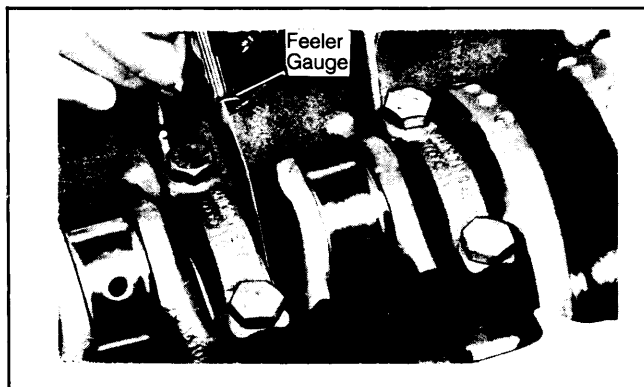

Also measure connecting rod side play.

2) Install plain bearing shell into bearing cap. Place grooved shell in block. Do not mix shells. Lubricate bearings and install caps.

**NOTE:** On No. 5 bearing, coat mating surface of bearing with sealing compound.

### ENGINE OILING

#### OIL CAPACITY

Capacity for 924 is 5.3 qts. (5.0L) with filter change, 4.7 qts. (4.5L) without filter change. For 924 Turbo capacity is 5.8 qts. (5.5L) with filter change, 4.7 qts. (4.5L) without filter change.

#### OIL FILTER

Filter is the spin-on type. Change at first oil change and every other one thereafter.

#### NORMAL OIL PRESSURE

Pressure should be 73-101 psi (5.1-7.1 kg/cm<sup>2</sup>) at 5000 RPM.

#### ENGINE OILING SYSTEM

The engine oiling system is full pressure with rotary (sickle) type pump. Oil is picked up by pump through strainer and suction tube. Oil passes through pump and pressure control valve to oil filter and main oil channels.

It is then distributed to main bearings, connecting rods and crankshaft. Camshaft lubrication is provided by spray tube at No. 1 cam bearing. Oil pressure switch is located at end of camshaft lubrication passage. A temperature sensor is located in oil pan.

Lubrication system for 924 Turbo includes the following additional components: An oil cooler in front of engine, oil filter flange with thermostat for the oil cooler, and delivery and return lines for the turbocharger.

**Fig. 12: Engine Oiling System**

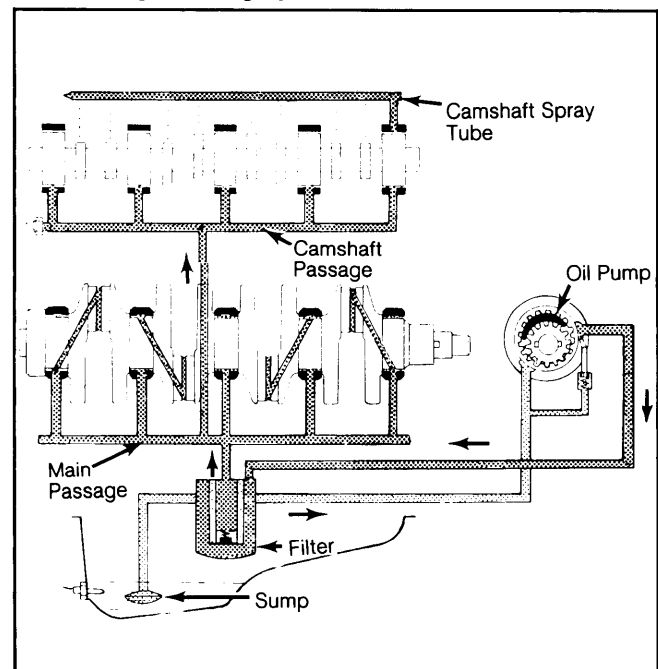

924 system shown, 924 Turbo similar.

# Porsche Engines

## 924 & 924 TURBO 4-CYLINDER (Cont.)

### OIL PUMP

Oil pump is gear driven sickle type. Pump is mounted at front of engine and driven directly by crankshaft. Gear replacement is in pairs only.

### ENGINE COOLING

#### COOLING SYSTEM CAPACITY

System capacity is 8.5 qts. (8.0L).

#### THERMOSTAT

Thermostat opens at 180°F (82°C).

#### RADIATOR CAP

Cap opens at 13.0-15.0 psi (.9-1.0 kg/cm<sup>2</sup>).

#### COOLING FAN

Fan comes on at 198°F (92°C) and goes off at 189°F (87°C).

### TIGHTENING SPECIFICATIONS

Application	Ft. Lbs. (N.m)
Cylinder Head Bolts	
924 .....	47 (64)
924 Turbo	
Step 1 .....	29 (40)
Step 2 .....	58 (79)
Step 3 .....	<sup>1</sup> 80 (110)
Main Bearing Caps .....	58 (79)
No. 5 Allen Head Bolt .....	47 (64)
Connecting Rod Nuts .....	43 (58)
Flywheel .....	<sup>2</sup> 65 (88)
Crankshaft Pulley .....	180 (245)
Exhaust Manifold .....	18 (24)
Intake Manifold .....	17 (23)
Camshaft Bearing Cap Bolts .....	7 (10)
Camshaft Bearing Cap Nuts .....	12-15 (16-20)
Camshaft Sprocket Bolt .....	58 (79)
<sup>1</sup> — Retighten 1 hour after warming engine. See text.	
<sup>2</sup> — On Turbo, flywheel is a press fit and must be heated to install.	

## ENGINE SPECIFICATIONS

### GENERAL SPECIFICATIONS

Year	Displacement		Fuel System	HP@RPM	Torque Ft. Lbs.@RPM	Compr. Ratio	Bore		Stroke	
	Cu. In.	cc					In.	mm	In.	mm
1982										
924	121	1984	Fuel Inj.	110@5750	111@3500	9.0:1	3.41	86.5	3.32	84.4
924 Turbo	121	1984	Fuel Inj.	154@5750	155@3500	8.0:1	3.41	86.5	3.32	84.4

### VALVES

Engine Size & Valve	Head Diam. In. (mm)	Face Angle	Seat Angle	Seat Width In. (mm)	Stem Diameter In. (mm)	Stem Clearance In. (mm)	Valve Lift In. (mm)
1984 cc Intake	1.575 (40.00)	45°	45°	.087-.118 <sup>1</sup> (2.20-3.00)	.3532 (8.970)	.0157 (.400)	....
Exhaust	1.299 <sup>2</sup> (33.00)	45°	45°	.087-.118 <sup>1</sup> (2.20-3.00)	.3524 (8.950)	.020 (.500)	....

<sup>1</sup> — Maximum seat width .138" (3.5 mm). <sup>2</sup> — 924 Turbo 1.417" (36 mm) diameter.

### PISTONS, PINS, RINGS

Engine	PISTONS	PINS		RINGS		
	Clearance In. (mm)	Piston Fit In. (mm)	Rod Fit In. (mm)	Ring No.	End Gap In. (mm)	Side Clearance In. (mm)
1984 cc	.0012" (.03)	....	.0004-.0008 (.10-.02)	....	.012-.020 (.3-.5)	.0016-.0028 (.04-.07)

# Porsche Engines

## 924 & 924 TURBO 4-CYLINDER (Cont.)

### ENGINE SPECIFICATIONS (Cont.)

#### CRANKSHAFT MAIN & CONNECTING ROD BEARINGS

Engine	MAIN BEARINGS				CONNECTING ROD BEARINGS		
	Journal Diam. In. (mm)	Clearance In. (mm)	Thrust Bearing	Crankshaft End Play In. (mm)	Journal Diam. In. (mm)	Clearance In. (mm)	Side Play In. (mm)
1984 cc	2.518-2.519 (63.95-63.97)	.0008-.0031 (.02-.08)	No. 3	.004-.007 (.10-.18)	1.888-1.889 (47.95-47.97)	.0008-.0027 (.02-.07)	.002-.003 (.05-.08)

#### VALVE TIMING

Engine	INTAKE		EXHAUST	
	Open (BTDC)	Close (ABDC)	Open (BBDC)	Close (ATDC)
1984 cc	6°	42°	47°	2°

#### CAMSHAFT

Engine	Journal Diam. In. (mm)	Clearance In. (mm)	Lobe Lift In. (mm)
1984 cc	1.0213-1.0220 (25.94-25.96)	.0015-.0032 (.040-.081)	....