

## 626, GLC & B2000 4-CYLINDER

### ENGINE CODING

#### ENGINE IDENTIFICATION

Engine number is stamped on a machined pad. On all models except GLC, engine number is located on right front side of engine block. On GLC models, engine number is located on block, near distributor.

### ENGINE & CYLINDER HEAD

#### ENGINE

##### Removal (RWD Models)

1) Remove hood after marking hinge location. Drain cooling system and crankcase. On GLC, remove cooling fan. On all models, remove battery and air cleaner. Disconnect accelerator cable and wiring wire from carburetor.

2) Disconnect fuel lines at fuel pump and carburetor. On automatic transmission models, disconnect and plug transmission cooler lines at radiator. On all models, remove radiator hoses and radiator.

3) Disconnect all engine vacuum hoses. Disconnect wires from temperature sending unit, oil pressure switch, alternator, distributor, back-up light switch and starter. Disconnect exhaust pipe from manifold.

4) On manual transmission models, remove cover plate from clutch housing and clutch slave cylinder. On automatic transmission models, remove drive plate-to-torque converter bolts.

5) On all models, support transmission with a jack and remove nuts and bolts attaching transmission to engine. Remove starter. On manual transmission models, remove clutch slave cylinder.

6) On all models, remove engine mount attaching nuts and bolts. Install a lifting sling to engine lifting brackets. Attach an engine hoist and raise slightly. Pull engine forward until clear of transmission. Lift engine from vehicle.

##### Removal (FWD Models)

1) Remove hood and battery. Raise and support vehicle. Remove engine undercover. Drain engine oil, transaxle oil and coolant. Remove the crossmember. Lift engine slightly and remove front wheels.

2) Detach steering knuckles. Remove drive-shafts from transaxle. Disconnect shifting rod and extension bar (if equipped) from transaxle. Remove lower hose from radiator. Remove transaxle mounting rubbers. Disconnect exhaust pipe from front catalytic converter.

3) Remove transaxle bracket. Remove air cleaner. Disconnect all electrical wiring from engine. Disconnect accelerator cable. Remove speedometer cable from transaxle. Disconnect clutch cable and bracket (if equipped), and ground cable from transaxle.

4) Remove upper radiator hose and heater hose. Disconnect all remaining hoses from engine. Remove canister. Disconnect engine mounting brackets. Lift engine and transaxle from vehicle at the same time.

##### Installation (All Models)

To install, reverse removal procedures.

#### CYLINDER HEAD

**NOTE:** Check timing chain for stretch prior to removing cylinder head. See Timing Chain & Sprockets procedures.

#### Removal

1) Remove engine lifting brackets from cylinder head. Disconnect exhaust pipe, then remove exhaust manifold. Disconnect ignition wires from spark plugs and remove cap from distributor.

2) Remove necessary vacuum hoses and wiring from distributor, then remove distributor. Disconnect hoses and remove air pump with bracket. Loosen drive belt, then remove water pump fan and pulley. Remove water pump.

3) If equipped, disconnect anti-afterburn valve. Label and disconnect all coolant, fuel and vacuum hoses from cylinder head, manifold and carburetor.

4) Label and disconnect all necessary wiring and cables from cylinder head, manifold and carburetor. Remove intake manifold and carburetor as an assembly.

5) Remove rocker arm cover. On RWD models, remove cover from timing chain tensioner. Install chain adjuster guide (49-3953-260) on tensioner to secure snubber in place. See Fig. 1. On FWD models, remove chain adjuster from front cover.

6) Secure flywheel in place to prevent crankshaft and camshaft from moving. Remove distributor drive gear from camshaft. Remove camshaft sprocket lock nut. Remove the 1 cylinder head-to-front cover attaching bolt.

7) Gradually loosen cylinder head bolts in reverse order of tightening sequence, then remove bolts. Wire camshaft sprocket and timing chain together to ensure correct chain-to-sprocket relationship for reassembly.

8) Remove rocker arm assembly. Keeping upward tension on timing chain, carefully remove camshaft from sprocket and cylinder head. Remove cylinder head.

**Fig. 1: Installing Chain Adjuster Guide on Timing Chain Tensioner**

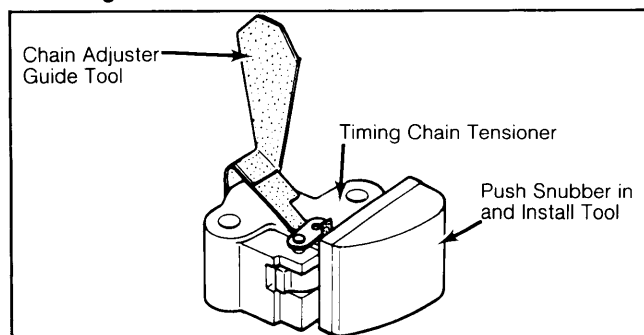

*Snubber must be held in retracted position when removing cylinder head, timing chain or camshaft.*

#### Installation

1) Clean all gasket mating surfaces. Install new head gasket. Place cylinder head on aligning dowels. If removed, install camshaft bearings in cylinder head and bearing caps. Lubricate bearings and camshaft journals with engine oil.

2) Install camshaft on cylinder head and engage with camshaft sprocket and timing chain. Install rocker arm assembly and head bolts.

3) Install the 1 cylinder head-to-front cover bolt. Tighten cylinder head bolts in sequence. See Fig. 2. Install and tighten remaining components in reverse order of removal. Ensure valve timing is correct. Adjust timing chain tension. Adjust valves.

# Mazda Engines

## 626, GLC & B2000 4-CYLINDER (Cont.)

**Fig. 2: Cylinder Head Tightening Sequence**

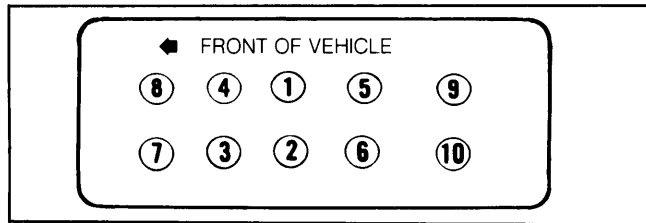

Loosen bolts in reverse order of tightening sequence.

### CAMSHAFT

### CAMSHAFT

### ENGINE FRONT COVER

Manufacturer does not give procedures for front cover removal and installation.

### VALVE TIMING

Valve timing procedures are explained in Timing Chain & Sprockets.

### TIMING CHAIN & SPROCKETS

#### Checking for Stretch (FWD Models)

1) Remove timing chain adjuster from front cover. Make sure sleeve is not locked. This would be the case if it were completely expanded.

2) Fit the chain adjuster on the front cover and press it in by hand until sleeve contacts adjuster blade. See Fig. 3.

3) Measure distance between the chain adjuster gasket and front cover. See Fig. 3. If measurement is .2" (5 mm) or less, replace timing chain.

**Fig. 3: Checking Timing Chain Stretch (FWD Models)**

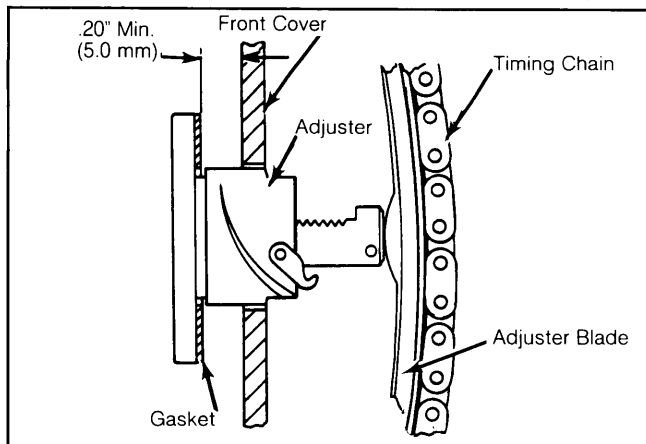

#### Checking for Stretch (RWD Models)

1) Remove cover from timing chain tensioner. Remove 2 blind plugs from front of front cover, then loosen chain guide strip screws.

2) On 1970 cc engines, remove blind plug on right side of front cover. Adjust timing chain tension by slightly rotating crankshaft in normal direction of rotation, then proceeding as follows:

3) Insert a screwdriver through access hole in side of front cover (or through top of cylinder head on

1490 cc engines) and press in on top of chain guide strip. DO NOT use excessive pressure.

4) While retaining pressure on guide strip, tighten guide strip screws through 2 holes in front cover. Chain is now adjusted.

5) To check for stretch, measure distance between rear face of snubber and tensioner housing. See Fig. 4. If distance exceeds .67" (17 mm), replace the chain.

**Fig. 4: Checking Timing Chain for Wear (RWD Models)**

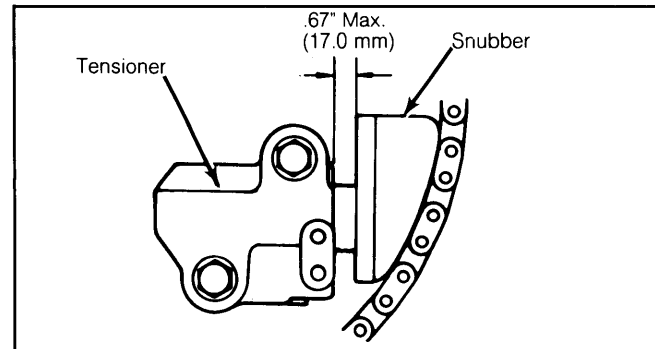

Adjust chain tension prior to taking measurement.

#### Removal

1) On FWD models, remove chain adjuster from front cover. On all models, remove cylinder head and engine front cover. On RWD models, remove chain adjuster from cylinder block. Loosen chain guide strip screws through access holes in front cover.

2) On RWD models, remove oil pump driven sprocket and drive chain from pump, then remove pump drive sprocket from crankshaft. Remove crankshaft timing sprocket and chain. On FWD models, remove crankshaft sprocket and timing chain.

#### Installation (RWD models)

1) Position crankshaft with keyway up. Place timing chain on crankshaft sprocket. On 1970 cc engines, 2 plated links of chain straddle timing mark on sprocket. On 1490 cc engines, plated link aligns with timing mark on crankshaft sprocket. See Fig. 5.

2) Install crankshaft sprocket and chain onto crankshaft, ensuring chain-to-sprocket positioning does not change. Install oil pump drive sprocket onto crankshaft. Install and tighten oil pump sprocket and drive chain on oil pump.

3) Install chain adjuster guide (49-3953-260) onto chain tensioner to keep snubber retracted. Install chain tensioner onto cylinder block. Using new head gasket, place cylinder head onto cylinder block.

4) Place timing chain around camshaft sprocket with timing mark and plated link aligned. Lay camshaft on cylinder head and engage camshaft with sprocket and chain. Ensure all timing marks are aligned. See Fig. 5.

5) Tighten camshaft sprocket. Install rocker arm assembly and cylinder head bolts. Tighten cylinder head bolts. Install front cover and oil pan.

6) Adjust timing chain tension by slightly rotating the crankshaft in the direction of engine rotation, then proceeding as follows:

7) Insert a screwdriver through access hole in side of front cover (or through top of cylinder head on 1490 cc engines) and press in on top of guide strip. DO NOT use excessive pressure. While retaining light pres-

## 626, GLC & B2000 4-CYLINDER (Cont.)

sure on guide strip, tighten guide strip screws through 2 holes in front cover.

8) Remove the timing chain adjuster guide from tensioner to release snubber. Install tensioner cover. Using new gaskets where required, install oil pan and remaining components in reverse order of removal.

### Installation (FWD models)

1) Install timing chain and crankshaft sprocket with timing marks aligned. See Fig. 5. Install front cover and oil pan. Using new gasket, place cylinder head in position on block.

2) Align camshaft sprocket timing mark with plated link on timing chain. Place camshaft onto cylinder head and engage camshaft into camshaft sprocket. Ensure timing marks are still aligned. See Fig. 5.

Fig. 5: Alignment Marks of Timing Chain & Sprockets

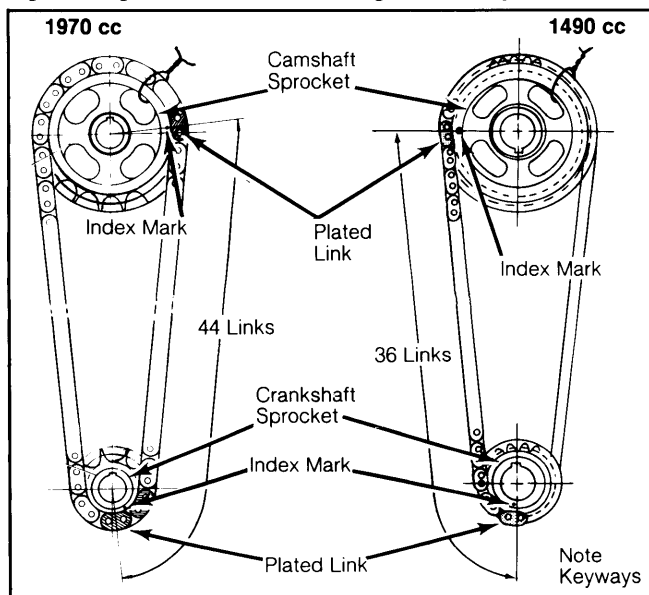

3) Install and tighten rocker arm assembly and head bolts. Install and tighten camshaft sprocket lock nut. Install crankshaft pulley, applying sealer to inside of pulley bolt.

Fig. 6: Locking Timing Chain Adjuster (FWD Models)

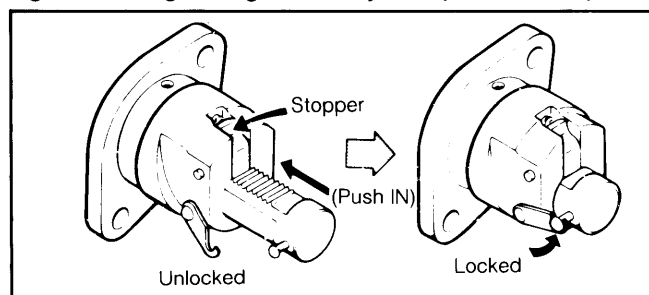

4) Push sleeve of timing chain adjuster into adjuster body and lock pin with hook. See Fig. 6. Install and tighten timing chain adjuster to front cover.

**NOTE:** Adjuster unlocks automatically and adjusts chain tension after engine is cranked once or twice.

5) Using new gaskets where necessary, install and tighten remaining components in reverse order of removal. If necessary, adjust valves.

### CAMSHAFT

#### Removal

1) Remove rocker arm cover. On RWD models, remove cover from timing chain tensioner. Install chain adjuster guide (49-3953-260) on tensioner to secure snubber in place. On FWD models, remove chain adjuster from front cover.

2) Secure flywheel in place to prevent crankshaft from moving. Remove distributor drive gear from camshaft. Remove camshaft sprocket lock nut. Remove cylinder head-to-front cover attaching bolt.

3) Gradually loosen cylinder head bolts in reverse order of tightening sequence, then remove bolts. Wire camshaft sprocket and timing chain together to ensure correct chain-to-sprocket relationship upon reassembly.

4) Remove rocker arm assembly. Keeping upward tension on timing chain, carefully remove camshaft from sprocket and cylinder head.

#### Inspection

1) Inspect camshaft journals and lobes for wear or scoring. Using a micrometer, measure cam lobe height. If measured height is less than specification, replace camshaft.

### CAM LOBE HEIGHT SPECIFICATIONS

Application	<sup>1</sup> Lobe Height In. (mm)
1490 cc	
FWD Models .....	1.7289 (43.914)
RWD Models .....	1.7288 (43.912)
1970 cc	
Intake Lobes .....	1.7652 (44.837)
Exhaust Lobes .....	1.7639 (44.804)

<sup>1</sup> — Minimum allowable measurement.

2) Measure diameter of camshaft bearing journals. If wear is more than .002" (.05 mm) below minimum standard diameter, camshaft must be ground or replaced.

3) Using a dial indicator, check camshaft out-of-round. Camshaft must not exceed .0012" (.030 mm) out-of-round.

#### Installation

To install, reverse removal procedure. Adjust timing chain tension as explained in Timing Chain & Sprockets.

### CAMSHAFT BEARINGS

#### Removal & Installaion

Remove camshaft. Remove bearing inserts from cylinder head and camshaft caps. To install, reverse removal procedures.

### CAMSHAFT END THRUST

Using a feeler gauge, check camshaft end thrust between sprocket and thrust plate. If end thrust measurement exceeds .008" (.20 mm), replace thrust plate.

# Mazda Engines

## 626, GLC & B2000 4-CYLINDER (Cont.)

### VALVES

#### VALVE ARRANGEMENT

##### 1490 cc FWD Engine

Firewall Side — Intake valves.

Exhaust Manifold Side — Exhaust valves.

##### 1490 cc RWD Engine

Right Side — Intake valves.

Left Side — Exhaust valves.

##### 1970 cc Engine

Left Side — Intake valves.

Right Side — Exhaust valves.

#### ROCKER ARM SHAFT ASSEMBLY

1) When disassembling rocker arm shaft assembly, keep all parts in order for reassembly. See Figs. 7 and 8. Inspect all components for wear or damage.

**Fig. 7: 1490 cc Rocker Arm Assembly**

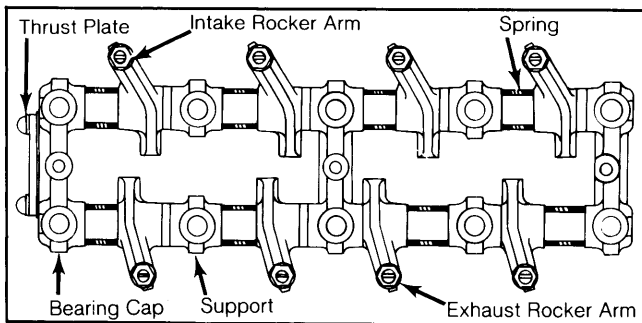

**Fig. 8: 1970 cc Rocker Arm Assembly**

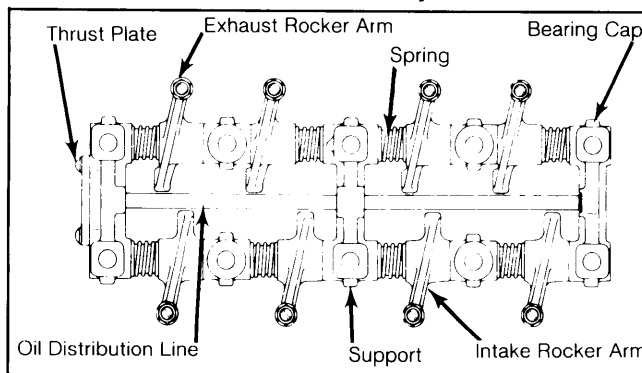

2) Standard clearance between rocker arm bore and shaft is .0008-.0029" (.020-.074 mm) for 1490 cc engines, and .0011-.0032" (.027-.081 mm) for 1970 cc engines. If clearance is more than .004" (.10 mm) replace worn components.

3) On 1970 cc engines, note that 2 rocker shafts are used on intake side. Install center bearing cap with oil hole on intake side.

4) 1970 cc engines use an "O" ring on oil distribution pipe to absorb vibration. Slide "O" ring onto pipe. Install pipe, then work "O" ring into hole in center camshaft cap. Be sure oil holes in pipe face downward.

5) Align rocker shaft assembly with dowels and install onto cylinder head. Before tightening cylinder head bolts, offset each rocker arm .040" (1.02 mm) from valve stem center, by shifting rocker shaft supports slightly. See Fig. 9.

**Fig. 9: Rocker Arm Offset**

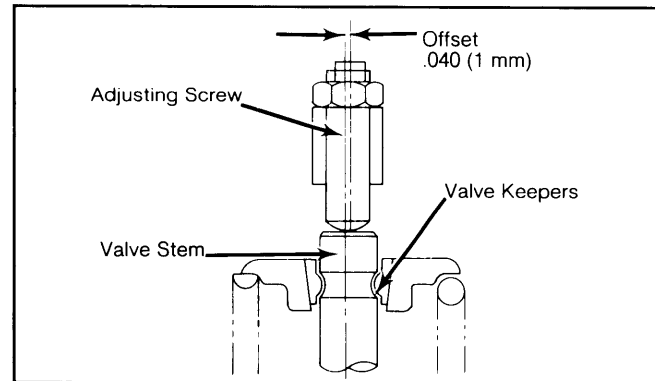

Move rocker arm supports to offset screws of intake and exhaust rocker arms.

#### VALVE GUIDE SERVICING

**CAUTION:** The valve keepers for intake and exhaust valves are not interchangeable. Care must be taken not to interchange them. See Fig. 10.

Use valve guide driver tool (49-0221-251A) to remove and install guides. When installing new guide, drive guide in until ring of guide just touches cylinder head. Always install new oil seal when valve components have been disassembled.

**Fig. 10: Intake & Exhaust Valve Keepers**

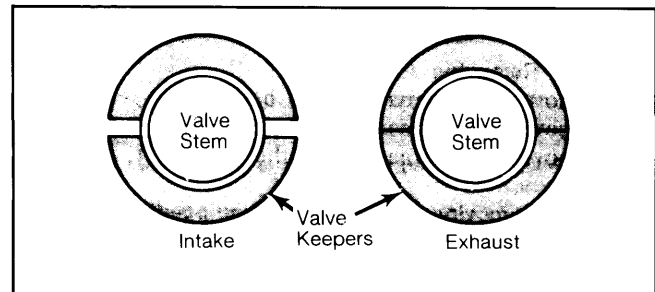

Do not interchange keepers.

#### VALVE STEM OIL SEALS

Remove cylinder head from vehicle and disassemble valve components to replace oil seals.

#### VALVE SPRINGS

##### Removal

Remove all carbon from inside of combustion chamber. Using a valve spring compressor, compress springs and remove keepers, retainers, valve springs and seats.

##### Inspection

1) With valve springs removed, inspect for damage. Use a valve spring tester test spring tension. Measure valve spring free length and compare with specifications.

2) Use a steel square and flat surface to check squareness of spring. If more than .056" (1.43 mm) out-of-square, replace spring.

##### Installation

To install valve springs and remaining components, reverse removal procedures.

## 626, GLC & B2000 4-CYLINDER (Cont.)

### VALVE CLEARANCE

1) Ensure head bolts are properly tightened. Warm engine to operating temperature. Valves can be adjusted at camshaft or valve stem.

2) Set No. 1 piston on TDC at end of compression stroke. Adjust intake valves of No. 1 and 2 cylinders, and exhaust valves of No. 1 and 3 cylinders. Turn crankshaft 1 full revolution and adjust remaining valves.

### VALVE CLEARANCE SPECIFICATIONS

Application	Intake In. (mm)	Exhaust In. (mm)
1490 cc		
Valve Side .....	.010 (.25)	.012 (.30)
Cam Side .....	.007 (.18)	.009 (.22)
1970 cc		
Valve Side .....	.012 (.30)	.012 (.30)
Cam Side .....	.009 (.22)	.009 (.22)

## PISTONS, PINS & RINGS

### OIL PAN

#### Removal

1) Remove protective cover from under engine. Drain engine oil. On FWD models, remove oil pan.

2) On RWD models, remove clutch release cylinder (if equipped). Leave hydraulic line attached. Remove clutch cover (if equipped). Remove oil pan.

#### Installation

Clean all gasket mating surfaces. Apply sealer to oil pan sealing surface. Using new gasket, install oil pan in reverse order of removal.

### PISTON & ROD ASSEMBLY

#### Removal

1) Remove oil pan, cylinder head, and oil pump. Make sure connecting rods and caps are marked so they can be replaced in their original positions.

2) Remove rod caps. Push piston and rod assembly out top of cylinder. Take care not to damage crankshaft journal.

#### Installation

1) Install piston rings on piston and properly space ring gaps. See Figs. 11 and 12. Lubricate piston rings, pistons and cylinder walls with engine oil. Install ring compressor onto piston without disturbing position of rings.

2) Install piston and rod assembly. Make sure "F" mark on pin boss is facing front of engine. Install rod caps and tighten rod bolts. Install oil pump, oil pan and cylinder head.

### FITTING PISTONS

1) Measure cylinder bore diameter at top, middle and bottom of bore. Take measurements in line with and 90° to crankshaft centerline. See Fig. 13.

2) Difference between minimum and maximum bore diameters must not exceed .006" (.15 mm). If wear exceeds limits, bore and hone cylinders for installation of oversize pistons.

Fig. 11: 1490 cc Engine Ring Gap Locations

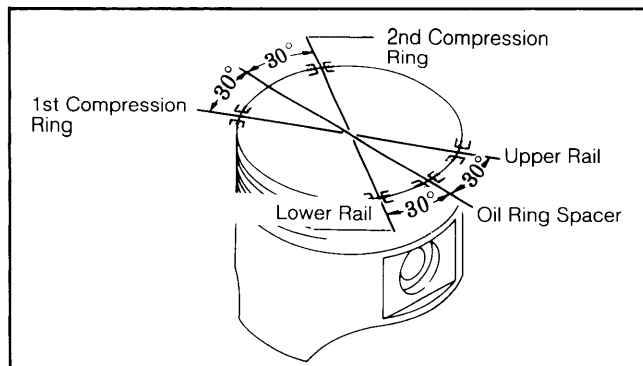
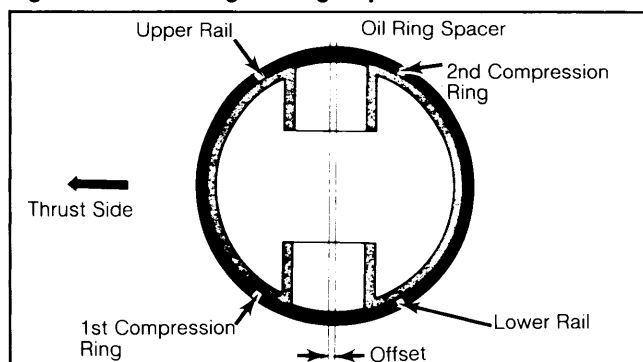

Fig. 12: 1970 cc Engine Ring Gap Locations



3) Inspect pistons and replace those severely damaged due to scoring, scratching or burning. Measure piston diameter 90° to pin bore, about 11/16" below lower ring groove. Use piston diameter and bore measurements to determine piston-to-cylinder bore clearance.

### FITTING RINGS

1) Position rings near bottom of bore at a point where bore diameter is smallest. Ring must be square in bore. Measure ring end gap with a feeler gauge.

2) Using a feeler gauge, check ring side clearance. Ensure rings turn freely in their ring grooves.

3) When installing rings on piston, ensure gaps are correct. See Figs. 11 and 12. Install compression rings with marking upward.

Fig. 13: Cylinder Bore Measuring Points

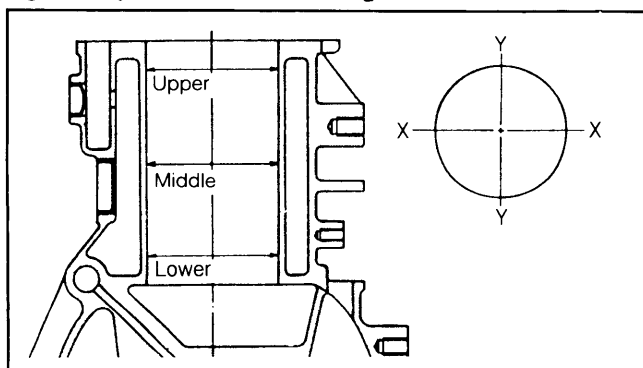

If difference between minimum and maximum bore measurements exceeds .006" (.15 mm), bore cylinders.

# Mazda Engines

## 626, GLC & B2000 4-CYLINDER (Cont.)

### PISTON PIN REPLACEMENT

1) Piston pin is press fit in connecting rod. Use pin remover/installer tool and adapters for removal and installation.

2) Assemble connecting rod to piston. See Fig. 14. When installed in engine, "F" mark on pin boss will face front of engine, and oil hole in connecting rod will be on right side of engine.

3) When installing pins, a press load of 1102-3307 lbs. (500-1500 kg) is required. If the press load is not within load range, replace the pin or connecting rod.

**Fig. 14: Correct Piston-to-Rod Relationship**

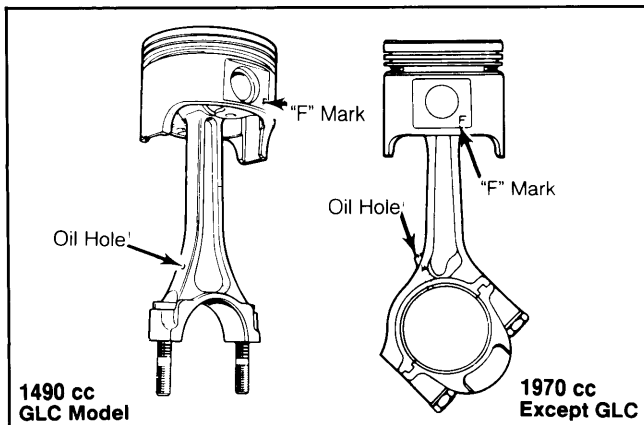

When installed in engine, "F" marking on pin boss will face front and oil hole in rod will be on right side.

### CRANKSHAFT MAIN & CONNECTING ROD BEARINGS

**NOTE:** Use Plastigage method to check clearances. Remove oil film from surfaces to be checked.

#### CRANKSHAFT MAIN BEARINGS

1) Note that main bearing caps are marked for cylinder identification. Arrow on cap points toward front of engine.

2) When removing rear main bearing cap, note installed position of cap side seals with relation to seal holes. Also, note position of thrust washers.

3) Check clearances 1 at a time. With all bearing caps tightened (except one being checked), check clearances using Plastigage method.

4) Using a micrometer, check crankshaft journals for taper. Taper must not exceed .002" (.05 mm).

5) To check crankshaft for straightness, place "V" blocks under crankshaft journals at both ends. Position dial indicator point on center journal.

6) Slowly turn crankshaft at least 1 full revolution, while recording crankshaft runout. Maximum runout is .0012" (.030 mm).

7) When installing thrust washers, be sure oil-grooved sides face thrust sides of crankshaft.

8) Install side seals between cylinder block and rear main bearing cap as follows: On RWD models, install seals with hole facing sideways. On FWD models, install seals with hole facing front or rear of engine.

### CONNECTING ROD BEARINGS

1) After ensuring rod caps are marked for cylinder identification, remove rod caps. Use Plastigage method to check for proper clearance.

2) If not within limits, install new bearings if crankpin is not worn beyond limits.

### CRANKSHAFT END THRUST

1) Attach a dial indicator to flywheel end of crankshaft. Pry crankshaft toward front of engine, then zero dial indicator.

2) Pry crankshaft rearward (toward dial indicator) and record end thrust. End thrust must not exceed .012" (.305 mm). If above limits, replace thrust washers.

3) Thrust washers are available in .010" (.25 mm), .020" (.50 mm) and .030" (.75 mm) oversizes.

### REAR MAIN BEARING OIL SEAL

With flywheel and oil pan removed, remove rear main bearing cap. Note installed positions of rubber side seals. Lubricate new seal lips and install onto crankshaft. Install rear main bearing cap and new rubber side seals.

## ENGINE OILING

### CRANKCASE CAPACITY

#### 1490 cc Engines

Capacity is 3.2 quarts (3.0L) without filter replacement; 3.9 quarts (3.7L) with filter replacement.

#### 1970 cc Engines

Capacity is 4.1 quarts (3.9L) without filter replacement; 4.7 quarts (4.5L) with filter replacement.

### NORMAL OIL PRESSURE

Oil pressure at 3000 RPM should be 50-64 psi (3.5-4.5 kg/cm<sup>2</sup>).

### ENGINE OILING SYSTEM

Oil is circulated by a rotor-type pump. On RWD model 1490 cc engines, pump is assembled to front of cylinder block. On all other models, pump is mounted to bottom of crankcase at front of engine. On all models, pumps are chain driven.

### OIL PUMP

#### Removal (1490 cc RWD)

Remove front cover. Remove sprocket and drive chain from oil pump. Remove pump cover. Note and record positions of index marks on rotors. Remove lock pin, pump shaft and rotors from cylinder block.

#### Disassembly

To remove pressure regulator valve, remove cotter pin from pump cover and extract components. See Fig. 15. Thoroughly clean all parts.

#### Inspection

1) With rotors installed in cylinder block, check rotor lobe clearance using a feeler gauge. If not within limits, replace both rotors.

2) With rotors installed in cylinder block, check clearance between outer rotor and bore in cylinder block using a feeler gauge. If not within limits, replace the rotor or cylinder block.

## 626, GLC & B2000 4-CYLINDER (Cont.)

3) Place a straightedge over rotors and cylinder block. Using a feeler gauge, measure clearance between rotors and straightedge. Record measurement.

4) Now lay a straightedge over pump cover at point where rotors and shaft contact cover. Using a feeler gauge, measure clearance between straightedge and cover.

5) Combine measurements taken in steps 3) and 4) to determine rotors end play. If combined measurements exceeds limits, grind (resurface) pump cover until correct clearance is obtained.

**Fig. 15: 1490 cc RWD Engine Oil Pump Assembly**

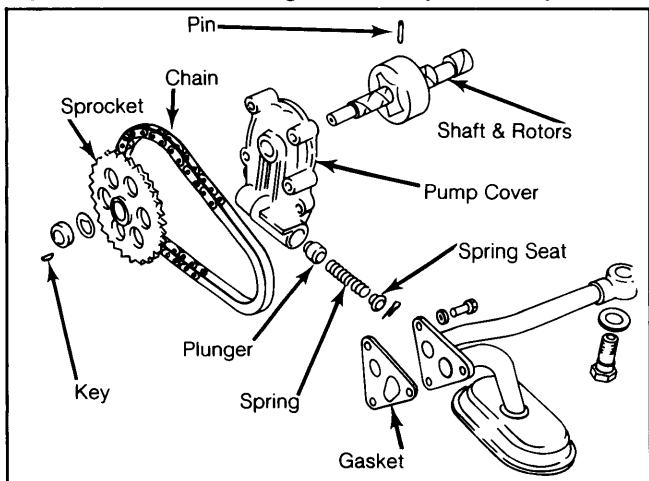

When installing rotors into cylinder block, be sure index marks on rotors face outward.

### 1490 cc RWD OIL PUMP SPECIFICATIONS

Application	Clearance In. (mm)
Rotor Lobe Clearance .....	.010 (.25) Max.
Outer Rotor to Bore Clearance .....	.012 (.30) Max.
Rotors End Play .....	.006 (.15) Max.

#### Removal (1490 cc FWD & 1970 cc)

Remove oil pan. Remove oil pump sprocket and detach chain from sprocket. Remove oil pump from cylinder block. Remove pump cover. Note and record positions of index marks on rotors. Extract shaft and rotors. See Figs. 16 and 17.

**Fig. 16: 1490 cc FWD Engine Oil Pump Assembly**

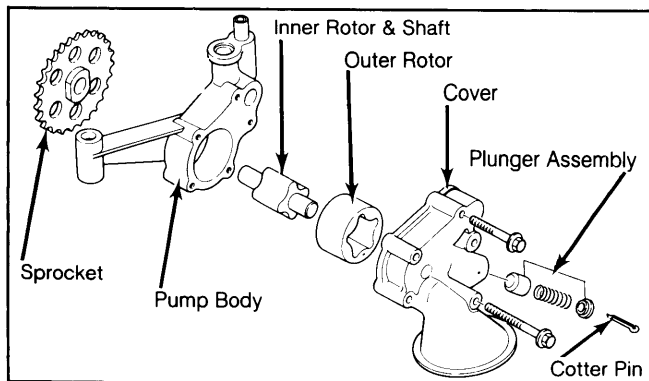

#### Reassembly & Installation

Lubricate pump parts, and reassemble in reverse order of disassembly. Install rotors into cylinder block so index marks face outward. Install remaining parts in reverse order of removal.

**Fig. 17: 1970 cc Engine Oil Pump Assembly**

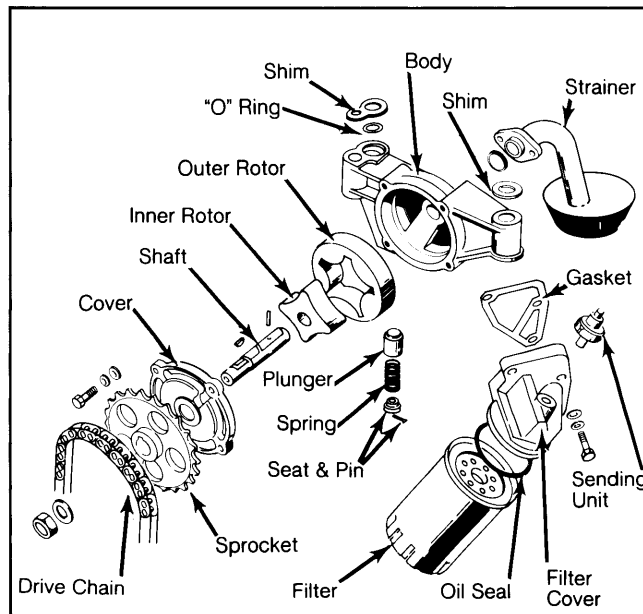

#### Disassembly

To remove oil pressure regulator components, remove cotter pin from pump body and extract spring seat, spring and plunger. Thoroughly clean all parts.

#### Inspection

1) Install rotors in pump body. Using a feeler gauge, measure clearance between rotor lobes. If excessive, replace both rotors.

2) Install rotors in pump body. Using feeler gauge, measure clearance between outer rotor and pump body. If beyond limits, replace rotor or pump body.

3) With rotors installed in pump body, lay a straightedge over pump body. Using a feeler gauge, measure clearance between rotors and straightedge. Record measurement.

4) Now lay a straightedge over pump cover and measure clearance between cover and straightedge at middle of cover. Record measurement.

5) Combine measurements in steps 3) and 4) to determine rotors end play. If sum of measurements exceeds specified limit, repair or replace pump body and/or cover.

#### Reassembly

Lubricate pump parts and reassemble in reverse order of disassembly. When installing rotors into pump body, be sure index marks on rotors are positioned toward pump cover.

#### Installation

Install oil pump in reverse order of removal. Check tension of oil pump drive chain, by pushing in on chain at a point midway between sprockets. If chain slack exceeds 5/32", install adjusting shims between pump and block.

# Mazda Engines

## 626, GLC & B2000 4-CYLINDER (Cont.)

### 1490 cc FWD & 1970 cc OIL PUMP SPECIFICATIONS

Application	Clearance In. (mm)
Rotor Lobe Clearance .....	.010 (25) Max.
Outer Rotor to Body	
FWD 1490 cc .....	.014 (.35) Max.
1970 cc .....	.012 (.30) Max.
Rotors End Play .....	.006 (.15) Max.

pulley from water pump. Detach water hoses from pump (if equipped). Remove water pump.

#### Removal (FWD Models)

Drain coolant. Remove engine undercover. Remove pump drive belt. Remove radiator hose, bypass hose and "O" ring. Remove water pump.

#### Installation (All Models)

Using a new gasket, install water pump by reversing removal procedure.

## ENGINE COOLING

### THERMOSTAT

On RWD 1490 cc engine, thermostat begins to open at 190°F (88°C) and is fully open at 212°F (100°C).

On all other models, thermostat begins to open at 180°F (82°C) and fully opens at 203°F (95°C).

### COOLANT CAPACITY

Coolant capacity (including heater) is 5.8 quarts (5.5L) for 1490 cc engines.

For 1970 cc engines, coolant capacity is 7.6 quarts (7.2L) for B2000 models, and 7.9 quarts (7.5L) for 626 models.

### RADIATOR CAP

Radiator cap pressure relief valve opens at approximately 13 psi (.9 kg/cm<sup>2</sup>).

### WATER PUMP

**NOTE:** It may be necessary to remove radiator to facilitate water pump removal.

#### Removal (RWD Models)

Drain cooling system. Remove cooling fan and radiator shroud (if necessary). Remove drive belts and

### TIGHTENING SPECIFICATIONS

Application	Ft. Lbs. (N.m)
1490 cc	
Camshaft Sprocket	
and Distributor Drive Gear .....	22-25 (30-35)
Connecting Rod Cap .....	22-26 (30-35)
Crankshaft Pulley .....	81-88 (110-120)
Cylinder Head .....	58-60 (78-82)
Exhaust Manifold .....	14-19 (19-26)
Flywheel .....	61-66 (83-90)
Intake Manifold .....	14-19 (19-26)
Main Bearing Cap .....	49-52 (66-71)
Oil Pump Sprocket .....	22-26 (30-35)
1970 cc	
Camshaft Sprocket .....	52-59 (70-80)
Connecting Rod Cap .....	30-34 (41-46)
Crankshaft Pulley .....	101-108 (140-149)
Cylinder Head	
Cold .....	66-70 (90-95)
Hot .....	70-74 (95-100)
Distributor Drive Gear .....	52-59 (70-80)
Exhaust Manifold .....	16-21 (22-29)
Flywheel .....	114-120 (155-163)
Intake Manifold .....	14-19 (19-26)
Main Bearing Cap .....	62-66 (84-90)
Oil Pump Sprocket .....	22-26 (30-35)

## ENGINE SPECIFICATIONS

### GENERAL SPECIFICATIONS

Year	Displacement		Fuel System	HP@RPM	Torque Ft. Lbs. @RPM	Compr. Ratio	Bore		Stroke	
	Cu. In.	cc					In.	mm	In.	mm
1982										
GLC	90.9	1490	1x2	.....	.....	9.0:1	3.03	77	3.15	80
B2000	120.2	1970	1x2	.....	.....	8.6:1	3.15	80	3.86	98
626	120.2	1970	1x2	.....	.....	8.6:1	3.15	80	3.86	98

### CRANKSHAFT MAIN & CONNECTING ROD BEARINGS

Engine	MAIN BEARINGS				CONNECTING ROD BEARINGS		
	Journal Diam. In. (mm)	Clearance In. (mm)	Thrust Bearing	Crankshaft End Play In. (mm)	Journal Diam. In. (mm)	Clearance In. (mm)	Side Play In. (mm)
1490 cc	1.9661-1.9668 (49.938-49.956)	.0009-.0017 (.023-.042)	No. 5	.004-.006 (.10-.15)	1.5724-1.5731 (39.940-49.956)	.0009-.0026 (.024-.066)	.004-.010 (.11-.26)
1970 cc	2.4780-2.4786 (62.940-62.955)	.0012-.0020 (.031-.050)	No. 5	.003-.009 (.08-.24)	2.0842-2.0848 (52.939-52.952)	.0011-.0030 (.027-.077)	.004-.008 (.11-.21)

# Mazda Engines

6-199

## 626, GLC & B2000 4-CYLINDER (Cont.)

### ENGINE SPECIFICATIONS (Cont.)

#### VALVES

Engine Size & Valve	Head Diam. In. (mm)	Face Angle	Seat Angle	Seat Width In. (mm)	Stem Diameter In. (mm)	Stem Clearance In. (mm)	Valve Lift In. (mm)
1490 cc Intake	1.4153-1.4193 (35.950-36.050)	45°	45°	.055 (1.40)	.3161-.3167 (8.030-8.045)	.0007-.0021 (.018-.053)	.....
			45°	.055 (1.40)	.3159-.3167 (8.025-8.045)	.0007-.0023 (.018-.058)	.....
1970 cc Intake	1.6495-1.6575 (41.900-42.100)	45°	45°	.055 (1.40)	.3161-.3167 (8.030-8.045)	.0007-.0021 (.018-.053)	.....
			45°	.055 (1.40)	.3159-.3167 (8.025-8.045)	.0007-.0023 (.018-.058)	.....

#### PISTONS, PINS, RINGS

Engine	PISTONS	PINS		RINGS		
	Clearance In. (mm)	Piston Fit In. (mm)	Rod Fit In. (mm)	Ring No.	End Gap In. (mm)	Side Clearance In. (mm)
1490 cc	.0015-.0020 (.026-.052)	.0003-.0010 (.008-.026)	1	1 & 2	.006-.012 (.15-.30)	.0012-.0028 (.030-.070)
				Oil	.012-.035 (.31-.89)	.....
1970 cc	.0019-.0025	1-.0009	1	1 & 2	.008-.016 (.020-.40)	.0012-.0028 <sup>2</sup> (.030-.070)
				Oil	.012-.035 (.31-.89)	.....

<sup>1</sup> — Interference Fit

<sup>2</sup> — Ring No. 2 side clearance is .0012-.0025" (.030-.064 mm).

#### CAMSHAFT

Engine	Journal Diam. In. (mm)	Clearance In. (mm)	Lobe Lift In. (mm)
1490 cc Front & Rear Center	1.6515-1.6522 (41.949-41.965)	.0014-.0030 (.035-.076)	.....
		1.6504-1.6510 (41.919-41.935)	.0026-.0042 (.065-.106)
1970 cc Front & Rear Center	1.7695-1.7701 (44.945-44.960)	.0007-.0027 (.019-.069)	.....
		1.7691-1.7697 (44.935-44.950)	.0011-.0031 (.029-.079)

#### VALVE SPRINGS

Engine	Free Length In. (mm)	PRESSURE Lbs. @ In. (Kg @ mm)	
		Valve Closed	Valve Open
1490 cc	1.71 (43.3)	63@1.32 (28.7@33.5)	.....
1970 cc Inner	1.45 (36.8)	21@1.26 (9.5@32)	.....
		31@1.34 (14.3@34.0)	.....