

Fiat Engines

SPIDER 2000 & 2000 TURBO 4-CYLINDER

ENGINE CODING

ENGINE IDENTIFICATION

Engine identification number is stamped on pad, above oil filter mount on left side of engine.

ENGINE IDENTIFICATION

Application	Code
1995 cc	132 C3.031

ENGINE & CYLINDER HEAD

ENGINE

Removal

1) Remove hood and air cleaner. Loosen fuel tank cap to release pressure. Disconnect battery. Label and disconnect all wiring, vacuum and fuel hoses and electrical leads attached to engine. Disconnect and remove accelerator linkage, at engine.

NOTE: On A/C equipped cars, it is necessary to discharge system and remove condenser prior to removal of engine. When installing, system will require evacuation and charging.

2) Drain cooling system. Disconnect cooling system hoses from engine. Disconnect automatic transmission cooling lines (if equipped). Remove radiator and cooling fan assembly.

3) Disconnect exhaust pipe at manifold. Remove automatic transmission dipstick from support bracket (if so equipped).

4) From underneath vehicle, remove oil filter, engine splash pans and any remaining electrical connections. Remove starter by passing through oil filter opening. (On A/C equipped vehicles, pull starter from mounted position and tie to engine until engine is removed.) Remove speedometer cable support bracket from engine mount.

5) Remove nuts and washers holding engine mount isolators to crossmembers. Remove ground strap to engine mount. Install transmission support and remove bolts securing transmission to engine. On automatic transmission models, remove bolts attaching flywheel to torque converter.

6) Attach engine sling and hoist engine until mount clears cross members. Move engine forward until clear and lift from engine compartment.

Installation

To install, reverse removal procedure. Ensure that pilot shaft engages clutch properly (manual transmission).

CYLINDER HEAD

Removal

1) Drain cooling system. Remove air cleaner and heated air tube. Disconnect battery ground cable. Loosen and remove tap radiator hose from thermostat housing. Remove union with hoses from attachment point at cylinder head. Remove timing belt cover.

2) Manually turn crankshaft so that holes in camshaft sprocket align with timing pointers. Block flywheel to prevent further turning and remove crankshaft

pulley. Remove lower timing cover. Remove oil dipstick tube. Loosen belt tensioner, and remove timing belt.

NOTE: A new belt must be installed any time tension is removed from timing belt. See Timing Belt Replacement.

3) Remove rear timing belt covers. From left side of engine, mark for identification and remove all fuel, vacuum, air and water hoses. Disconnect accelerator and remove linkage. At engine right side, remove primary wires from distributor, and white lead wire from electronic control module.

4) Mark for identification and remove all remaining wires, hoses and tubes that would interfere with cylinder head removal. Disconnect exhaust pipe from manifold. Remove automatic transmission fluid dipstick (if equipped) from support bracket. Remove cylinder head bolts, and lift off head assembly.

Installation

1) Position camshafts so that reference marks on sprockets are aligned with fixed pointers on front of head. Ensure that crankshaft is positioned so that No. 1 and No. 4 pistons are at TDC. Install guide stud at front and rear of block.

2) Place new head gasket in position on cylinder head. Guide head over studs, ensuring that camshafts are not moved from reference position. Install 4 head bolts finger tight, then remove guide studs.

3) Install remaining bolts and tighten. See Fig. 1. To complete installation, reverse removal procedure.

NOTE: Use Kent Moore Tool No. 28036 (Fiat No. 50149) to torque bolts.

Fig. 1: Cylinder Head Tightening Sequence

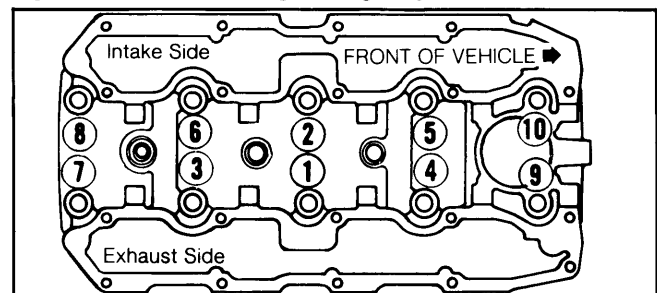

Tighten cylinder head bolts in 3 steps.

CAMSHAFTS

CAMSHAFTS

Removal

1) With cylinder head removed from engine, remove distributor and manifolds. Install pulley holder (A.60446) at front of cam housing and remove bolt, washer and pulley from camshaft.

2) Remove attaching bolts and lift off cam housing with camshaft. Remove cap from rear of housing and remove camshaft. Repeat procedure for other camshaft.

Installation

To install, reverse removal procedure, noting that distributor drive gear is on exhaust camshaft.

SPIDER 2000 & 2000 TURBO 4-CYLINDER (Cont.)

AUXILIARY SHAFT

Auxiliary shaft is driven by timing belt, and drives oil pump and fuel pump. With engine out of vehicle and front crankshaft pulley removed, remove auxiliary shaft drive pulley. Remove auxiliary shaft cover and gasket. Remove spacer and gasket. Rotate auxiliary shaft to raise oil pump gear and lift gear out with long needlenose pliers. Remove bolts holding retainer at front of block and pull out shaft along with retainer. To install, reverse removal procedure.

TIMING BELT REPLACEMENT

NOTE: Timing belts must not be reused once tension is relieved from belt. Crankshaft and/or camshafts must not be turned with belt removed due to resultant valve and/or piston damage.

Removal

1) Disconnect battery ground cable. Drain cooling system. Remove spark plugs, and rotate crankshaft until No. 4 piston is TDC on its compression stroke. Crankshaft and camshaft timing marks must be aligned with indicators. Remove upper radiator hose from "T" union, then unbolt and remove union from cylinder head.

2) Remove hot air hose from exhaust manifold.

Remove all drive belts from crankshaft pulley. Remove water pump pulley bolts, and remove pulley. Remove outer timing belt cover.

3) Lock crankshaft to prevent turning and remove crankshaft pulley. Remove lower timing belt cover. Loosen belt tensioner and lock in belt-slack position. Remove and discard timing belt.

Installation

Turn auxiliary sprocket to align hole in sprocket with sprocket bolt and spring retaining bolt. Install belt and adjust tensioner, then rotate crankshaft 2 full turns and recheck tension, and valve timing. See Fig. 2. To complete installation, reverse removal procedures.

Fig. 2: Sprocket Alignment for Timing Belt Installation

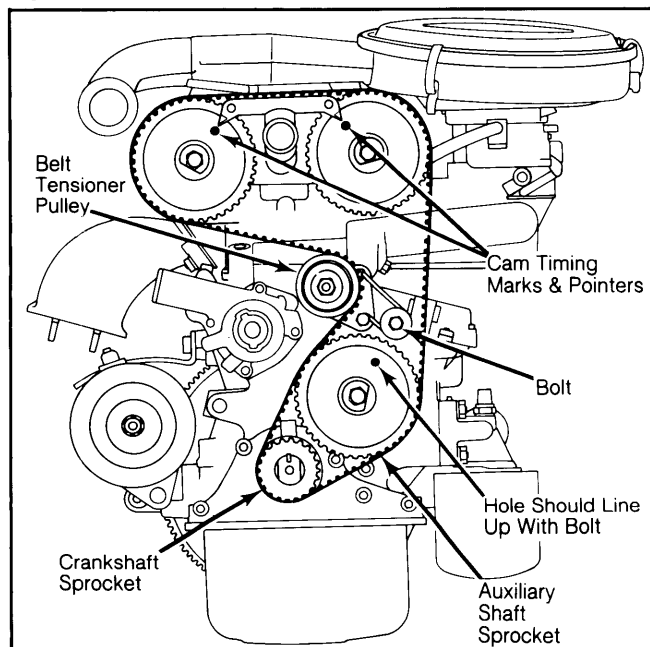

VALVES

VALVE ARRANGEMENT

Left Side — Intake valves.

Right Side — Exhaust valves.

VALVE GUIDE SERVICING

1) Measure clearance of valve stem in guide with a dial indicator. If clearance exceeds specifications, valve guide must be replaced.

2) With driver tool (A.60153/60395), remove defective guides from head, driving from combustion chamber side. Press new guide in place from camshaft side with drift (A.60462). Guides are prefinished to size. Minor flaws caused during replacement procedure, may be corrected by hand reaming valve guide.

VALVE STEM OIL SEALS

Removal

1) Remove spark plug from cylinder No. 1. Piston should be approximately 2/3 of the way up the cylinder. Screw in compressor gauge hose/adaptor into spark plug hole and connect an air hose, pressurizing cylinder to approximately 120-150 psi (8.4-10.5 kg/cm²).

2) Using valve spring compressor, compress valve springs. Remove valve keepers. Slowly release tension from spring. Remove tool, spring retainer, inner and outer springs and lower spring seat from valve stem. Remove valve stem oil seal. Ensure that all portions of seal have been removed from valve guide.

Installation

1) Using a light grease, lubricate the seal protector pin (60313/1) of valve guide seal installer and protector (Kent-Moore J28069). Place protector pin on end of valve stem. Slide new oil seal down pin and valve stem onto guide. Remove protector pin.

2) Place installer (60313/2) over valve stem seal. Lightly tap end of installer until oil seal is properly seated on valve guide. Remove installer. Reinstall lower spring seat, inner and outer springs and spring retainer. Using valve spring compressor, compress valve springs and install valve keepers.

3) Repeat procedure for other valve of cylinder No. 1. After seal replacement, remove air hose, reinstall spark plug and repeat procedure on remaining cylinders. Reinstall camshaft housing and related parts onto cylinder head. See Camshaft Removal and Installation in this section. Install a new timing belt.

VALVE SPRINGS

Removal & Installation

With cylinder head removed, remove camshaft carriers and camshafts. Compress valve spring with a valve spring compressor and remove keepers. Release valve spring compressor and remove upper spring retainer, inner and outer springs and lower spring retainer. To install, reverse removal procedure.

VALVE CLEARANCE ADJUSTMENT

1) Valve clearance is checked and/or adjusted with engine cold. Remove camshaft cover from head and rotate crankshaft until camshaft lobe of valve being checked is pointing up and at right angle to valve. Using a

Fiat Engines

SPIDER 2000 & 2000 TURBO 4-CYLINDER (Cont.)

feeler gauge, check clearance between camshaft lobe and valve tappet plate. See Fig. 3.

VALVE CLEARANCE SPECIFICATIONS

Application	In. (mm)
Intake016-.019 (.41-.49)
Exhaust018-.021 (.46-.54)

2) Tappet plates are available in thicknesses of .128" (3.25 mm) and increments of .004" (.10 mm) from .130" to .185" (3.30 mm to 4.70 mm). To replace tappet plate, rotate camshaft down to depress tappet. Install clamping tool (A.60594) over cam lobe of valve being adjusted.

3) Rotate crankshaft/camshaft and remove tappet plate by means of a scribe notch in tappet. As an alternate method, tappet may be pried down using tool (A 60443) and tappet plate removed with a scribe. Insert proper thickness tappet plate and remove tool.

Fig. 3: Checking and Adjusting Valve Clearance

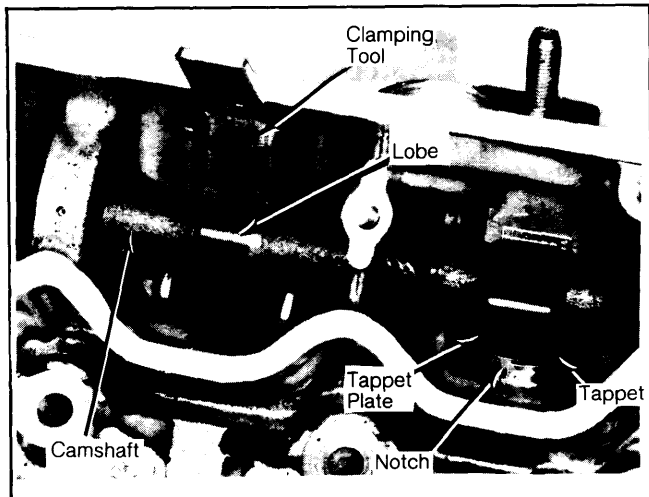

PISTONS, PINS & RINGS

OIL PAN

Removal

1) Drain crankcase. Remove engine splash shields. Remove nuts from engine mounts at crossrails. Raise engine about 6".

2) Remove flywheel inspection plate. Remove oil pan bolts. Strike pan lightly with rubber mallet, to free oil pan from block assembly.

Installation

To install, clean all mating surfaces and install gasket with sealer applied to both sides. Reverse removal procedure and tighten bolts evenly.

PISTON & ROD ASSEMBLY

Lubricate cylinder bores, wrist pins and bearing journals with light engine oil. Ensure that piston ring gaps are staggered approximately 120° apart and that pistons and rings are coated lightly with engine oil. Use ring compressor and install assembly so that numbers on connecting rod and cap are facing away from auxiliary shaft.

FITTING PISTONS

1) Standard pistons are manufactured in 3 size classes, and cylinder bores are machined according to piston class. Class of piston and bore are designated by a letter code.

2) Class code of piston is stamped on bottom of piston pin boss. Class of cylinder bore is stamped next to appropriate cylinder on oil pan flange at bottom of cylinder block.

3) Measure piston size at right angles to piston pin and 1.181" (30 mm) from piston skirt. If piston is replaced for any reason, one of the same class must be installed.

NOTE: Refer to class designation letter on bottom of piston pin boss and mating surface of crankcase. See Fig. 4 and 5.

Fig. 4: Piston and Rod Assembly Markings

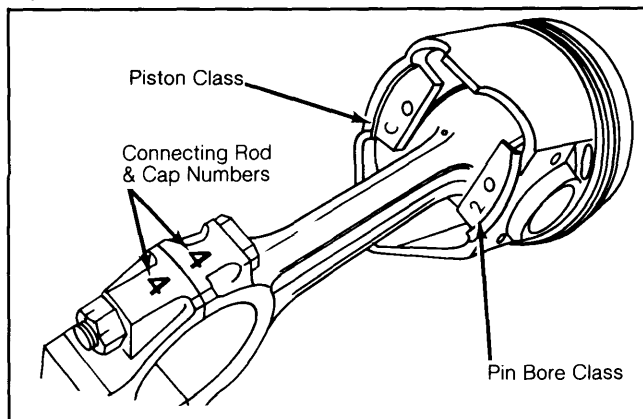

STANDARD PISTON CLASS DESIGNATION & SIZE

Class	In. (mm)
A	3.3051-3.3055 (83.95-83.96)
C	3.3059-3.3063 (83.97-83.98)
E	3.3066-3.3070 (83.99-84.00)

4) Measure cylinder bore lengthwise and crosswise near top, center and bottom of bore. Check piston fit in bore at right angles to pin 1.876" (47.65 mm) below piston head using a feeler gauge. If clearance exceeds .0059" (.15 mm), cylinders must be rebored and oversized pistons installed.

OVERSIZE PISTONS

Application	Amt. of Oversize In. (mm)
1st Oversize0079 (0.2)
2nd Oversize0157 (0.4)
3rd Oversize0236 (0.6)

NOTE: If replacement pistons are used, ensure that the 4 pistons are the same weight within .18 oz. (5 g).

5) Check ring side clearance in piston grooves prior to installation on piston. Push rings squarely into cylinder bores and check ring gaps with feeler gauge. Install rings on pistons with gaps 120° apart.

SPIDER 2000 & 2000 TURBO 4-CYLINDER (Cont.)

PISTON PIN REPLACEMENT

1) Remove circlips from piston and push piston pin out of piston and connecting rod. Separate piston from connecting rod and check pin clearance in piston and rod. If clearance is excessive, piston and connecting rod must be rebored for a .0079" (.2 mm) oversize pin.

2) Bushing in small end of rod is replaceable and requires a .0017-.0040" (.043-.102 mm) interference fit. To assemble piston and rod, piston side with offset portion of pin bore must be on same side as numbers on connecting rod and cap. Oil piston pin and insert in piston and rod. Install circlips and check alignment and freedom of movement.

Fig. 5: Piston Bore Class Designation Marks

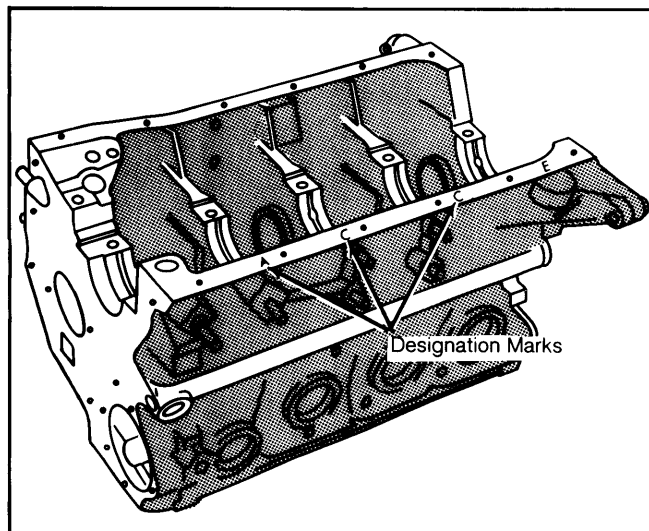

Class code of piston is stamped on bottom of piston pin boss.

CRANKSHAFT MAIN & CONNECTING ROD BEARINGS

MAIN & CONNECTING ROD BEARINGS

1) With crankshaft removed, thoroughly clean and inspect for cracks or scoring on journals. Check all journals for out-of-round condition, using a micrometer. If journal is out-of-round or tapers more than .0002" (.005 mm), crankshaft must be reground for undersize bearings.

2) Bearing-to-journal clearance is checked using the Plastigage method. If clearance exceeds specifications, crankshaft must be ground for undersize bearings. Main and connecting rod bearings are available in .010" (.25 mm), .020" (.51 mm), .030" (.76 mm), and .040" (1.02 mm) undersizes.

NOTE: Main bearing caps are stamped with a number that must correspond to the number stamped on crankcase near flywheel. Notches on caps face auxiliary shaft side and coincide with position. Front main bearing cap has no notch, however 2nd, center 4th and rear caps have 1, 2, 3, and 4 notches respectively.

CRANKSHAFT END PLAY

Check crankshaft end play, using a dial indicator mounted at front of engine. Pry crankshaft back and forth, and read clearance. If beyond specifications, install new thrust washers to bring end play within limits.

ENGINE FRONT COVER & OIL SEAL

Engine front cover oil seal should be replaced whenever front cover is removed. Make sure new seal is squarely seated in cover. Lubricate seal contact lip before installing cover.

ENGINE OILING

CRANKCASE CAPACITY

Normal drain and refill capacity of engine oiling system is 4.3 qts. (4.0L).

OIL FILTER

Full-flow, cartridge type.

NORMAL OIL PRESSURE

Oil pressure is 50-71 psi (3.5-5.0 kg/cm²) at 212°F (100°C) and 4000 RPM.

PRESSURE REGULATOR VALVE

Installed in pump cover.

ENGINE OILING SYSTEM

Engine oiling system is full pressure lubrication utilizing a gear type oil pump driven by the auxiliary shaft. A full-flow filter and a pressure regulator valve is also used.

OIL PUMP

Removal

1) Drain crankcase and remove oil pan. See *Oil Pan*. Remove 2 bolts and washers holding oil pump to engine and remove pump and gasket. Visually inspect all parts for wear or damage.

2) Check gears for tooth-to-housing clearance. Clearance should be .004-.007" (.11-.18 mm). Place straightedge across pump body and measure gear end play. End play should be .0010-.0051" (.026-.131 mm). Check relief valve spring for pressure of at least 12.7 lbs. (5.8 kg) at .886" (22.5 mm).

Fig. 6: Checking Oil Pump Gear End Play

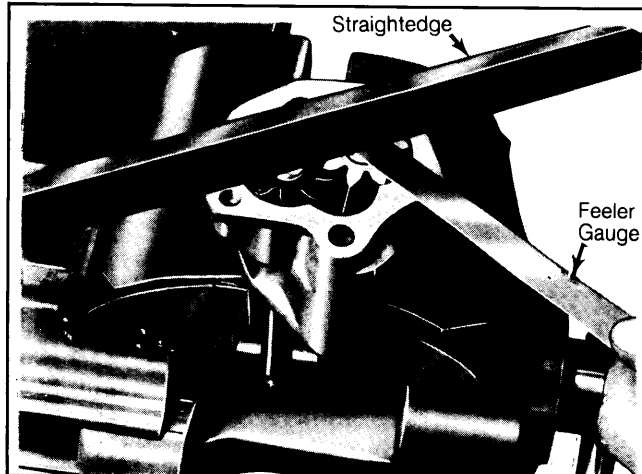

Fiat Engines

SPIDER 2000 & 2000 TURBO 4-CYLINDER (Cont.)

Installation

To install, reverse removal procedure and mount pump using a new gasket. Make sure pump is seated before tightening mounting bolts.

Remove radiator hose from water pump. Remove 4 mounting bolts, then remove pump.

Installation

To install, ensure that mating surfaces are clean. Install new gasket and reverse removal procedure.

ENGINE COOLING

THERMOSTAT

Opens at 172-180°F (78-82°C).

THERMOSWITCH

Operates at 194°F (90°C).

COOLING SYSTEM CAPACITY

8.5 quarts.

RADIATOR CAP

11 psi (.8 kg/cm²).

WATER PUMP

Removal

Drain cooling system. Remove 3 water pump pulley bolts. Remove drive belt and water pump pulley.

TIGHTENING SPECIFICATIONS

Application	Ft. Lbs. (N.m)
Cylinder Head Bolts ¹	69 (94)
Main Bearing Cap Bolts	
Front	59 (80)
Center & Rear	83 (113)
Intake & Exhaust Manifold Nuts	18 (24)
Intake Manifold Bolts	18 (24)
Connecting Rod Nuts	54 (73)
Flywheel-to-Crankshaft Bolt	105 (143)
Camshaft Sprocket Bolt	87 (118)
Oil Pump Mounting Bolt	14 (19)
Timing Belt Tensioner Nut	33 (45)

¹ — Tighten when cold. Recheck after 700-1000 miles.

ENGINE SPECIFICATIONS

GENERAL SPECIFICATIONS

Year	Displacement		Fuel System	HP@RPM	Torque Ft. Lbs.@RPM	Compr. Ratio	Bore		Stroke	
	Cu. In.	cc					In.	mm	In.	mm
1982 Fuel Inj. Turbo	121.7 121.7	1995 1995	Fuel Inj. Fuel Inj.	102@5500 120@6000	110@3000 130@3600	8.2:1 8.2:1	3.31 3.31	84 84	3.54 3.54	90 90

VALVES

Engine Size & Valve	Head Diam. In. (mm)	Face Angle	Seat Angle	Seat Width In. (mm)	Stem Diameter In. (mm)	Stem Clearance In. (mm)	Valve Lift In. (mm)
1995 cc Intake	1.638-1.654 (41.6-42.0)	45.5°	45°	.079 (2.0)	.3139-.3146 (7.974-7.992)	.0012-.0026 (.030-.066)	.3765 (9.564)
Exhaust	1.412-1.435 (35.85-36.45)	45.5°	45°	.079 (2.0)	.3139-.3146 (7.974-7.992)	.0012-.0026 (.030-.066)	.3765 (9.564)

PISTONS, PINS, RINGS

Engine	PISTONS	PINS		RINGS		
	Clearance In. (mm)	Piston Fit In. (mm)	Rod Fit In. (mm)	Ring No.	End Gap In. (mm)	Side Clearance In. (mm)
1995 cc	.0016-.0024 (.040-.060)	.0001-.0003 (.002-.008)	.0004-.0006 (.010-.016)	No. 1	.0118-.0177 (.30-.45)	.0018-.0030 (.045-.077)
				No. 2	.0118-.0177 (.30-.45)	.0011-.0027 (.030-.070)
				Oil	.0098-.0157 (.25-.40)	.0011-.0024 (.030-.062)

SPIDER 2000 & 2000 TURBO 4-CYLINDER (Cont.)

ENGINE SPECIFICATIONS (Cont.)

CRANKSHAFT MAIN & CONNECTING ROD BEARINGS

Engine	MAIN BEARINGS				CONNECTING ROD BEARINGS		
	Journal Diam. In. (mm)	Clearance In. (mm)	Thrust Bearing	Crankshaft End Play In. (mm)	Journal Diam. In. (mm)	Clearance In. (mm)	Side Play In. (mm)
1995 cc	2.086-2.087 (52.99-53.00)	.001-.003 (.03-.07)	No. 5	.002-.012 (.05-.30)	1.9997-2.0001 ¹ (50.79-50.80)	.001-.003 ² (.03-.07)

¹ — Diameter is machined in 2 sizes designated by class codes. Specification is class "A". Class "B" is smaller by .0004" (.010 mm).

² — Varies according to class of connecting rod journal. Specification is class "A". Class "B" clearance is larger by .0001" (.002 mm).

VALVE SPRINGS

Engine	Free Length In. (mm)	PRESSURE Lbs. @ In. (Kg @ mm)	
		Valve Closed	Valve Open
1995 cc Inner Spring	1.646 (41.8)	33@1.220 (14.9@31)	62@.846 (28.1@21.5)
Outer Spring	2.122 (53.9)	86@1.417 (38.9@36)	141@1.043 (63.9@26.5)

VALVE TIMING

Engine	INTAKE		EXHAUST	
	Open (BTDC)	Close (ABDC)	Open (BBDC)	Close (ATDC)
1995 cc	5°	53°	53°	5°

CAMSHAFT

Engine	Journal Diam. In. (mm)	Clearance In. (mm)	Lobe Lift In. (mm)
1995 cc Front	1.1788-1.1795 (29.94-29.96)	.0019-.0035 (.049-.090)	.3765 (9.56)
Middle	1.8013-1.8020 (45.75-45.77)	.0011-.0027 (.029-.070)	.3765 (9.56)
Rear	1.8171-1.8178 (46.15-46.17)	.0011-.0027 (.029-.070)	.3765 (9.56)