

Datsun/Nissan Engines

280ZX, 280ZX TURBO & MAXIMA 6-CYLINDER

ENGINE CODING

ENGINE IDENTIFICATION

Engine serial number is stamped on right rear side of cylinder block below mating surface of head.

ENGINE IDENTIFICATION

Application	Engine Size	Code
Maxima	2393 cc	L24E
280ZX	2753 cc	L28E
280ZX Turbo	2753 cc	L28ET

ENGINE, MANIFOLDS & CYLINDER HEAD

ENGINE

NOTE: Remove engine and transmission as a unit. Engine can then be separated from transmission assembly.

Removal

1) Remove engine hood. Bleed off fuel pressure as follows: Start engine. Disconnect fuel pump relay harness connector with engine running. After engine stalls crank engine 2 or 3 times. Turn ignition switch off. Disconnect battery ground cable.

NOTE: On models equipped with power steering and/or air conditioner, remove power steering pump and/or air conditioner compressor from engine but DO NOT disconnect lines. Suspend pump and/or compressor with wire to prevent damage to hoses.

2) Drain cooling system, and engine crankcase. Remove radiator hoses. Remove air cleaner and disconnect hoses from canister, then remove canister. Disconnect transmission oil cooler lines (automatic transmission models), and remove radiator and shroud.

3) Remove lower engine splash guard (if equipped). Disconnect accelerator linkage. Disconnect wiring to starter, alternator, oil pressure switch, neutral switch, back-up light switch, EGR solenoid valve, electronic fuel injection harness and connector, throttle valve switch, cold start valve, air regulator, vacuum cutting solenoid (manual transmission models), auxiliary cooling fan (if equipped), and distributor.

4) Remove canister hoses. Disconnect wiring to boost controlled deceleration solenoid valve. Disconnect engine ground cable to engine, and high tension cable between coil and distributor. Disconnect wire for block terminal.

5) Disconnect fuel return hose and fuel charge hose, heater hoses, and all vacuum hoses. On models with automatic transmission, disconnect wire to inhibitor switch and downshift solenoid.

6) Remove clutch operating cylinder on models with manual transmission. Disconnect speedometer cable from rear extension housing. Remove center console, "C" ring, and control lever pin from transmission striking rod guide, then remove control lever on models with manual transmission. On models with automatic transmission, disconnect shift control lever.

7) Disconnect exhaust pipe from exhaust manifold. Disconnect exhaust pipe bracket from rear extension housing and tie exhaust pipe out of the way. Mark propeller shaft and pinion flange to aid in reassembly, then remove propeller shaft from vehicle.

8) Plug rear of extension housing to prevent oil leakage. Support transmission with a jack and remove rear engine mount. Use a hoist to raise engine and remove front engine mount attaching bolts. Raise engine and transmission and remove from vehicle as a unit.

Installation

1) To install, reverse removal procedures and note that rear engine mount is attached to vehicle first.

2) Ensure proper routing and attachment of all electrical harnesses, vacuum and water hoses. Refill all fluids to specified level before starting engine.

MANIFOLDS

Removal

1) Disconnect battery ground cable and drain cooling system. Disconnect hose connecting rocker cover to throttle chamber at rocker cover. Disconnect tube connecting heater housing to water inlet at water inlet.

2) Remove bolt securing water and fuel tubes to cylinder head. Bleed off fuel pressure as described in engine removal procedure. Remove tube connecting heater housing to thermostat housing.

3) Disconnect fuel line and remove intake manifold mounting bolts. Remove intake manifold and attached components. Disconnect exhaust pipe from exhaust manifold (outlet).

4) Remove PCV valve hose, sub-heat shield plate and EGR tube. On turbocharged models, disconnect oil passage tube from turbocharger, and remove turbocharger and exhaust outlet as a unit. Remove exhaust manifold mounting bolts and take off manifold.

Installation

To install, use new gasket and reverse removal procedure.

Fig. 1: Intake Manifold Assembly

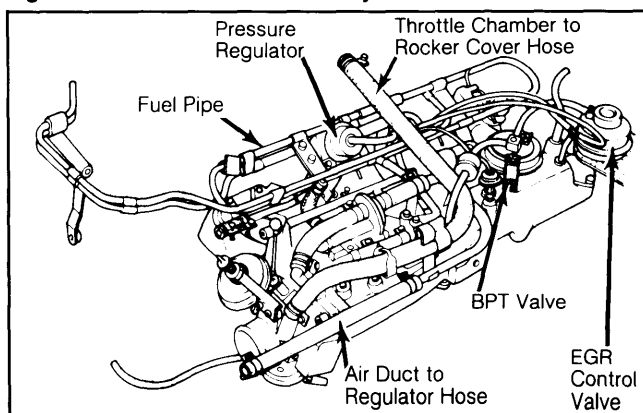

Non-Turbo shown, Turbo models are similar.

CYLINDER HEAD

Removal

1) Drain cooling system and disconnect upper radiator hose and heater hoses. Release fuel hose pressure as described in engine removal procedure. Remove air regulator and all connecting hoses as an assembly.

280ZX, 280ZX TURBO & MAXIMA 6-CYLINDER (Cont.)

2) Remove spark plug wires at plug end. Remove EGR control valve, vacuum switching valve and hoses as an assembly. Remove throttle chamber with dash pot and boost controlled deceleration device.

3) Remove fuel lines, vacuum hoses, and canister purge hose pressure regulator. Remove thermostat housing and all attached switches as an assembly. Remove PCV valve hose, sub-heat shield plate, and EGR tube.

NOTE: Remove clip attaching fuel inlet hose to injector and take care not to twist or bend hose during removal.

4) Remove intake manifold and heat shield plate. Remove turbocharger with exhaust outlet (if equipped). Remove exhaust manifold. Remove all drive belts. Remove camshaft sprocket attaching bolt and remove sprocket from timing chain.

5) Remove oil pipe. Remove cylinder head attaching bolts in reverse of tightening sequence. See Fig. 2. Remove bolts securing cylinder head to timing cover. Remove cylinder head from engine block.

NOTE: Use special tool (KV10105800) to support timing chain so timing marks on crankshaft sprocket and timing chain will remain unchanged. This will simplify timing mark alignment during reassembly.

Installation

1) Ensure that mating surfaces of cylinder head and block are clean, then install cylinder head and gasket without sealer. Number 1 piston should be at TDC on compression stroke.

CAUTION: Do not rotate crankshaft and camshaft separately or valves may hit head of pistons.

Fig. 2: Cylinder Head Tightening Sequence

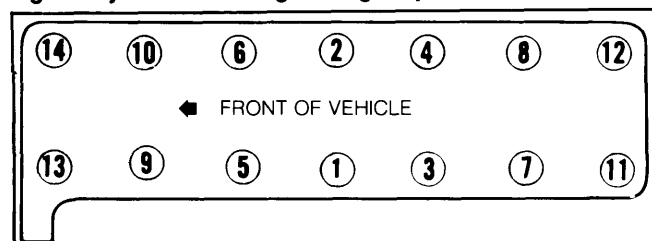

Loosen in reverse sequence.

2) Insert head bolts and tighten first 2 in tightening sequence to 14 ft. lbs. (19 N.m). Install and align sprockets and timing chain. Install remaining components in reverse order of removal, using new seals, gaskets and sealant where required.

3) Tighten head bolts in several steps in the sequence illustrated in Fig. 2 to final specified torque. Recheck torque after engine has been running for several minutes.

CAMSHAFT

CAMSHAFT

Removal

1) Remove cylinder head. Remove valve rocker springs. Loosen valve rocker pivot lock nuts and remove rocker arms by pressing down on spring.

2) Use care not to lose valve rocker guide. Carefully remove camshaft from front of cylinder head.

Installation

1) Carefully install camshaft into cylinder head taking care not to damage bearings. Install camshaft locating plate with oblong groove of plate facing front of cylinder head.

2) Install camshaft sprocket and tighten attaching bolt. Install remaining components in reverse of removal procedure, and tighten all nuts and bolts.

CAMSHAFT BEARINGS

NOTE: Do not remove camshaft bearings. If bearings are removed, bearing centers will be out of alignment and proper reassembly will be difficult without center boring.

Measure inner diameter of camshaft bearings and outer diameter of camshaft journals. If excessively worn or damaged, replace camshaft and/or cylinder head assembly. In event of excess end play, replace locating plate.

ENGINE FRONT COVER

Removal

1) Drain cooling system, disconnect hoses and remove radiator. Remove all drive belts, fan blade and pulley. Disconnect all wiring and connections to thermostat housing and remove housing.

2) Remove crankshaft pulley and water pump. Remove spark plug wires from plugs, mark position of distributor base to engine and position of rotor to distributor.

3) Disconnect distributor wires from coil and remove distributor. Remove oil pump with its drive spindle. Remove front cover attaching bolts and front cover.

Installation

1) Apply sealant to front cover gasket, front of cylinder block, and top of front cover. Install front cover on cylinder block. Tighten front cover-to-cylinder block bolts and cylinder head-to-front cover bolts.

2) Install oil pump with drive spindle. Install distributor while aligning index marks. Reconnect spark plug wires and all distributor connections.

3) Install thermostat housing and reconnect all wiring. Install fan and pulley. Install drive belts, radiator, hoses, and fill cooling system and oil pan.

TIMING CHAIN

Removal

Remove engine front cover. Remove camshaft drive sprocket, timing chain, tensioner and chain guide. Remove oil slinger, crankshaft worm gear and crankshaft sprocket.

Installation

1) Install components in reverse of removal procedure while noting the following: When installing timing chain, camshaft sprocket or crankshaft sprocket, make sure camshaft and crankshaft keys point upward.

2) Set timing chain so that its mating marks match marks on crankshaft and camshaft sprockets on right-hand side. Locate camshaft dowel pin in No. 1 hole in camshaft sprocket.

Datsun/Nissan Engines

280ZX, 280ZX TURBO & MAXIMA 6-CYLINDER (Cont.)

Fig. 3: Timing Chain and Sprocket Installation

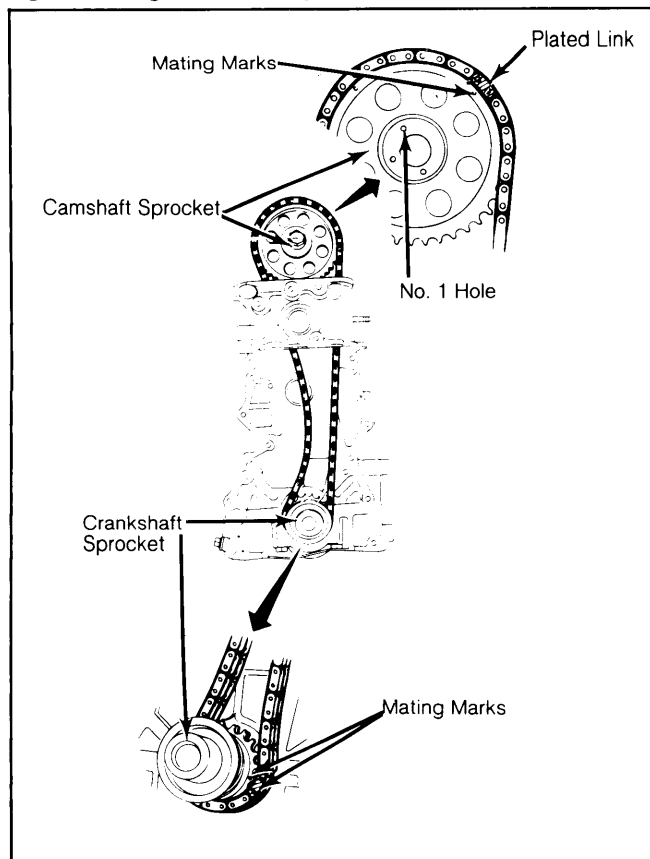

Make sure camshaft and crankshaft keys point upward.

VALVES

VALVE ARRANGEMENT

E-I-I-E-I-E-E-I-E-I-I-E (Front-to-rear).

VALVE GUIDES CHECKING

1) Measure clearance between valve stem and valve guide with aid of micrometer and hole gauge. Check diameter of valve stem in three places: top, center and bottom.

2) Insert hole gauge in valve guide bore and measure at center. Subtract highest reading of valve stem diameter from valve guide bore to obtain clearance.

NOTE: As a quick check, a valve may be inserted into valve guide and moved either left or right (parallel with rocker arm). If tip moves .008" (.2 mm) or more, clearance is beyond maximum limit of .004" (.1 mm).

VALVE GUIDE REPLACEMENT

1) Using a press and drift pin, force worn guide from cylinder head working from combustion chamber side. Although this procedure may be carried out at room temperature, higher temperatures will aid removal.

2) With head at room temperature, ream valve guide hole to .4815" (12.23 mm). Heat head to 300-400°F (150-200°C) and install new guide.

3) Ream bore of valve guides to .3150-.3157" (8.000-8.018 mm). Correct valve seat surface using new valve guide as axis.

VALVE SEAT INSERTS

Check valve seats for pitting at valve contact surface. Valve seat inserts of .020" (.5 mm) oversize are available if necessary.

VALVE STEM OIL SEALS

An oil seal is installed on all intake and exhaust valve stems inside of valve spring.

VALVE SPRINGS

Removal

1) With cylinder head removed, loosen pivot lock nut and remove rocker arm by pressing valve spring down, taking care not to lose valve rocker guide. Remove camshaft taking care not to damage camshaft bearings and cam lobes.

2) Compress valves and remove valve keepers. Remove compressing tool, then remove spring retainer, inner and outer springs, oil seal and valve spring seat.

Installation

1) Install spring seat and fit oil seal onto valve guide. Install valve springs, ensuring that close coiled end (painted white) of outer spring is against head.

2) Install retainers, keepers and rocker guides. Install camshaft. Press valve springs down using a screwdriver and install rocker arms. Install valve rocker springs.

VALVE SPRING INSTALLED HEIGHT

1) Outer valve spring must be less than .087" (2.2 mm) and inner spring must be less than .047" (1.2 mm) out of square.

2) Valve spring installed height is 1.38" (35 mm) for inner spring and 1.57" (40 mm) for outer spring. If spring height, pressure or squareness do not meet specifications, replace spring.

VALVE ADJUSTMENT

1) Valves cannot be adjusted while engine is in operation. Cold settings are shown to provide initial clearance after assembly. Warm engine to operating temperature and remove valve cover.

2) Rotate crankshaft so No. 1 exhaust cam lobe points up and adjust exhaust valve clearance on No. 1, 4 and 5 cylinder. Adjust intake valves on No. 2, 4 and 6 cylinder.

3) Rotate crankshaft 360° so that lobe of No. 1 exhaust valve points down. Adjust exhaust valve clearance on No. 2, 3 and 6, and intake clearance on No. 1, 3 and 5 cylinder.

VALVE ADJUSTMENT CLEARANCES

Valve	Hot	Cold
Intake	.010" (.25 mm)	.007" (.18 mm)
Exhaust	.012" (.30 mm)	.010" (.25 mm)

280ZX, 280ZX TURBO & MAXIMA 6-CYLINDER (Cont.)

PISTONS, PINS & RINGS

PISTON & ROD ASSEMBLY

Removal

1) With cylinder head and oil pan removed, remove connecting rod nuts. Remove rod cap with bearing half. Push piston/rod assembly with bearing half up and out through top of engine.

2) Rod caps must be kept with their respective piston and rod assembly as caps are not interchangeable.

Installation

1) To install piston and connecting rod assembly, thoroughly oil rings, piston and cylinder wall.

2) Make sure ring gaps are situated approximately 180° apart and not on thrust side of piston or in line with piston pin. Make sure bearing halves are properly seated in connecting rod and cap.

3) Install a ring compressor and compress rings. Install piston in cylinder with notch mark on piston head toward front of engine. With piston installed in cylinder, and connecting rod and bearings seated against crankshaft journal.

4) Install rod caps to their respective piston and rod assembly. Oil jet of connecting rod should face right side of cylinder block. Install cylinder head and oil pan.

FITTING PISTONS

1) Visually inspect cylinder block for cracks or flaws. Using a bore gauge, measure cylinder for out-of-round or excessive taper. If cylinder bore out-of-round or taper exceeds .0008" (.02 mm), refinish cylinder bore. When any one cylinder is bored, all cylinders must be bored.

2) Determine piston oversize according to amount of wear in cylinder (see specifications). By measuring piston at thrust face and adding mean of piston-to-cylinder clearance, finish hone of cylinder may be determined.

3) After honing cylinder to final fit, measure piston-to-cylinder clearance using pull scale and feeler gauge. Extracting force to pull scale should be .44-3.31 lbs. (.2-1.5 kg) using a .0016" (.04 mm) feeler gauge.

4) If cylinder bores are worn beyond limits, undersize cylinder liners are available. Liners should have an interference fit of .0031-.0035" (.08-.09 mm) in cylinder block.

PISTON SPECIFICATIONS

Piston Size In. (mm)	Piston Diameter In. (mm)
280ZX (includes Turbo)	
Standard	3.3844-3.3864 (85.965-86.015)
.020 (.50) O/S	3.4041-3.4061 (86.465-86.515)
.040 (1.0) O/S	3.4238-3.4258 (86.965-87.015)
Maxima	
Standard	3.2663-3.2683 (82.965-83.015)
.020 (.50) O/S	3.2860-3.2880 (83.465-83.515)
.040 (1.0) O/S	3.3057-3.3077 (83.965-84.015)

PISTON PINS

1) Using press and related adaptors, remove piston pin from piston and connecting rod. Measure pin bore diameter in piston and connecting rod. If wear exceeds specifications, replace both piston and pin.

2) Pin must fit piston with light thumb pressure at room temperature. Piston pin is a press fit (interference) in connecting rod. If connecting rod is replaced, insure that new rod is within .247 ounce (7 grams) of the defective connecting rod.

3) Install piston pin to piston and connecting rod so oil hole on connecting rod will face right side of engine and notch on piston head will face forward when assembly is installed.

Fig. 4: Piston and Connecting Rod Alignment

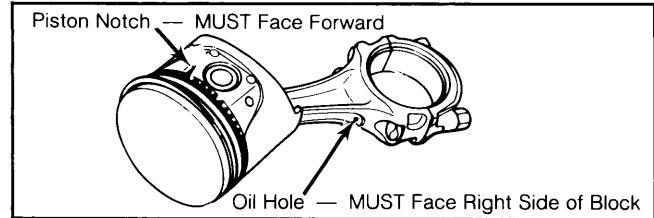

Oil hole on connecting rod faces right side of engine.

CRANKSHAFT MAIN & CONNECTING ROD BEARINGS

CRANKSHAFT

Removal

1) With engine removed from vehicle, remove cylinder head and oil pan. Remove flywheel and end plate. Remove oil pump, front cover, chain tensioner and chain guides.

2) Remove timing chain, oil thrower, crankshaft worm gear, and chain drive sprocket. Remove piston and rod assemblies. Remove main bearing caps using a puller (KV10104150) to remove center and rear main bearing caps. Remove rear oil seal, then remove crankshaft.

NOTE: Keep all main bearing caps in order to aid in reassembly.

Fig. 5: Removing Center Main Bearing Cap

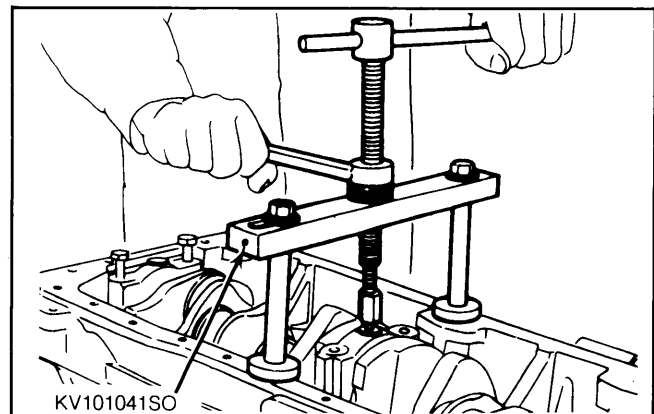

Remove bearing cap slowly.

Inspection

1) Check shaft journals and crankpins for scoring, wear, or cracks. Taper and out-of-round of journals and crankpins must not exceed .0012" (.03 mm). Check crankshaft for bend using a dial indicator at center journal of crankshaft.

Datsun/Nissan Engines

280ZX, 280ZX TURBO & MAXIMA 6-CYLINDER (Cont.)

2) If bend exceeds .004" (.10 mm), which is one-half of indicator reading, replace crankshaft. Check main drive shaft pilot bearing at rear of crankshaft for wear or damage and replace if necessary.

Installation

1) Install main bearing halves to engine block ensuring that all bearings are on correct journal. Journal No. 4 requires a thrust bearing. Bearing for journal No. 1 is the same as for journal No. 7. Upper bearing halves have an oil groove and are not interchangeable with lower bearing halves.

2) Apply oil to main bearing surface and install crankshaft. Apply sealant to each side of rear main bearing cap and corners of cylinder block contact point. Install bearing caps so arrow faces front of engine.

3) Shift crankshaft toward front of engine, then tighten main bearing caps in 2 or 3 steps, starting at center bearing and working outward. Ensure crankshaft rotates smoothly. Check crankshaft end play, and if not within specifications, replace center thrust bearing.

4) Install side seals in rear main bearing cap after applying sealer to seals. Install rear oil seal. Install rear end plate and flywheel. Install piston and rod assemblies.

5) Install cylinder head, crankshaft sprocket, worm gear, chain drive sprocket, oil thrower, and timing chain. Install chain guides and tensioner, front cover, oil pump and oil pan. Install remaining components in reverse of removal procedure.

Fig. 6: Checking Crankshaft End Play

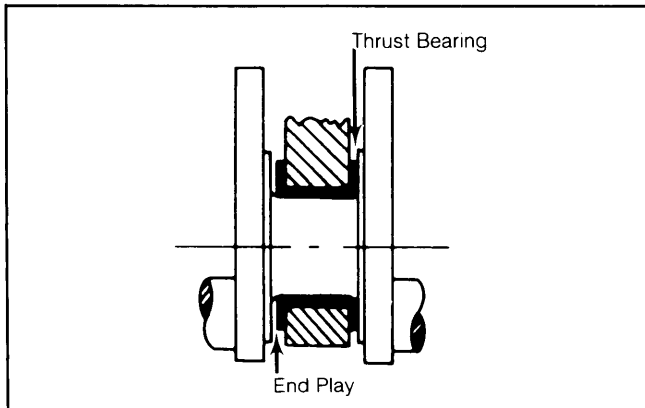

Thrust bearing is located at center main bearing journal.

MAIN BEARING CLEARANCE

1) Check all bearings for scoring or wear and replace if damage is found. Clean oil from crankshaft and place a strip of Plastigage on crankshaft journal. Install main bearing cap, with bearing installed and tighten to 33-40 ft. lbs. (45-54 N.m).

NOTE: Plastigage should run parallel with crankshaft and journal and should not block oil hole. Do not turn crankshaft while Plastigage is inserted.

2) Remove cap and measure width of Plastigage at widest point using gauge provided with Plastigage. If clearance is not to specifications, replace bearings. Bearings are available in undersizes of .01" (.25 mm), .02" (.50 mm), .03" (.75 mm), and .04" (1.0 mm).

CONNECTING ROD BEARING CLEARANCE

Check connecting rod bearing clearance in same manner as main bearing clearance, using Plastigage. Tighten connecting rod caps to 33-40 ft. lbs. (45-54 N.m). Bearings are available in undersizes of .0024" (.06 mm), .005" (.12 mm), .01" (.25 mm), .02" (.50 mm), .03" (.75 mm) and .04" (1.0 mm).

ENGINE OILING

CRANKCASE CAPACITY

Maxima 5.3 qts. (with filter).
280ZX 4.8 qts. (with filter).
280ZX Turbo 5.5 qts. (with filter).

OIL FILTER

Full-flow, with disposable cartridge.

OIL PRESSURE

50-57 psi (3.5-4.0 kg/cm²) @ 2000 RPM.

ENGINE OILING SYSTEM

Oil drawn from oil pan passes through a screen to oil pump. Oil is delivered to full-flow filter and main oil gallery. Main oil gallery supplies oil to crankshaft main bearings and drilled passages in crankshaft. Oil sprayed from jet holes on connecting rods lubricates chain tensioner and timing chain.

A center oil hole in the crankshaft center bearing feeds camshaft bearings on cylinder head. Valve rocker mechanism is lubricated through oil gallery in camshaft and through a channel at base circle portion of each cam. Rocker arms and valves are lubricated through holes in oil pipe.

NOTE: On turbocharged models an oil cooler, oil passage tube to turbo housing, and special oil filter mounting bracket (for oil cooler supply and return lines) are added. Oil passage tube taps into main oil gallery in cylinder block. Lubricant drains from housing through oil tube to oil pan.

OIL PUMP

1) Oil pump assembly is installed to bottom of front cover by four bolts. Pump is driven by oil pump drive spindle assembly which is in turn driven by gear on crankshaft.

2) To remove oil pump, first remove distributor. Drain engine oil and remove oil pump body together with drive spindle. To disassemble, proceed as follows: Remove pump cover and gasket.

3) Slide pump rotors from pump body. Remove regulator cap, valve and spring. Clean all components with cleaning solvent, and inspect for wear or damage. Check the clearances indicated in the following table and ensure clearances are to specifications.

4) If components are not to specifications, replace entire pump assembly. Assemble pump in reverse order of disassembly while aligning hole in oil pump with punch mark on drive spindle. Fill pump housing with oil before installing to front cover.

280ZX, 280ZX TURBO & MAXIMA 6-CYLINDER (Cont.)

OIL PUMP SPECIFICATIONS

Application	Clearance In. (mm)
Rotor Tip Clearance	Less Than .0079 (.20)
Outer Rotor-to-Body	Less Than .0197 (.50)
Rotor-to-Cover	Less Than .0024 (.06)
Rotor Side Clearance	Less Than .0012 (.03)

ENGINE COOLING

THERMOSTAT

Opens at 180°F (82°C).

COOLING SYSTEM CAPACITY

11 qts.

RADIATOR CAP

13 psi.

WATER PUMP

Centrifugal type pump with aluminum body. To remove, drain cooling system and remove fan shroud. Remove fan belts, fan, and pulley. Remove pump attaching bolts and remove water pump from front cover.

TIGHTENING SPECIFICATIONS

Application	Ft. Lbs. (N.m)
Cylinder Head	51-61 (69-83)
Connecting Rod	33-40 (45-54)
Flywheel	94-108 (128-147)
Camshaft Gear	94-108 (128-147)
Crankshaft Pulley	101-116 (137-158)
Main Bearing Cap	33-40 (45-54)
Rocker Pivot Lock Nuts	36-43 (49-58)
Intake & Exhaust Manifolds	
8 mm Bolts	11-18 (15-24)
8 mm Nuts	9-12 (12-16)
10 mm Bolts	25-33 (34-45)
	INCH Lbs. (N.m)
Oil Pan	52-86 (6-10)
Oil Pump-to-Front Cover	96-132 (11-15)
Oil Pump Cover	52-86 (6-10)
Camshaft Lock Plate	52-86 (6-10)
Front Cover	
6 mm Bolts	35-86 (4-10)
8 mm Bolts	84-144 (10-16)

ENGINE SPECIFICATIONS

GENERAL SPECIFICATIONS

Year	DISPLACEMENT		Fuel System	HP@RPM	Torque Ft. Lbs.@RPM	Compr. Ratio	BORE		STROKE	
	Cu. In.	Liters					In.	mm	In.	mm
1982										
L24E	146.0	2393	Fuel Inj.	8.9:1	3.27	83	2.90	73.7
L28E	168.0	2753	Fuel Inj.	8.8:1	3.39	86	3.11	79
L28ET	168.0	2753	Fuel Inj.	7.4:1	3.39	86	3.11	79

VALVES

Engine Size & Valve	Head Diam. In. (mm)	Face Angle	Seat Angle	Seat Width In. (mm)	Stem Diameter In. (mm)	Stem Clearance In. (mm)	Valve Lift In. (mm)
2393 cc							
Int.	1.65 (42.0)	45.5°	45°	.061 (1.55)	.3136-.3142 (7.965-7.980)	.0008-.0021 (.020-.053)
Exh.	1.38 (35.0)	45.5°	45°	.055 (1.4)	.3128-.3134 (7.945-7.960)	.0016-.0029 (.040-.073)
2753 cc							
Int.	1.73 (44.0)	45.5°	45°	.061 (1.55)	.3136-.3142 (7.965-7.980)	.0008-.0021 (.020-.053)
Exh.	1.38 (35.0)	45.5°	45°	.061 (1.55)	.3128-.3134 (7.945-7.960)	.0016-.0029 (.040-.073)

¹ — Interference fit.

² — Turbo engines .0075-.0130" (.19-.33 mm).

Datsun/Nissan Engines

280ZX, 280ZX TURBO & MAXIMA 6-CYLINDER (Cont.)

ENGINE SPECIFICATIONS (Cont.)

PISTONS, PINS, RINGS

Engine	PISTONS	PINS		RINGS		
	Clearance In. (mm)	Piston Fit In. (mm)	Rod Fit In. (mm)	Ring No.	End Gap In. (mm)	Side Clearance In. (mm)
2393 cc & 2753 cc	.0010-.0018 (.025-.045)	.0002-.0005 (.006-.013)	.0006-.0013 ¹ (.015-.033)	No. 1	.0098-.0157 ² (.25-.40)	.0016-.0029 (.040-.073)
				No. 2	.0059-.0118 (.15-.30)	.0012-.0025 (.030-.066)
				Oil	.012-.035 (.3-.9)	.0009-.0028 (.023-.070)

CRANKSHAFT MAIN & CONNECTING ROD BEARINGS

Engine	MAIN BEARINGS				CONNECTING ROD BEARINGS		
	Journal Diam. In. (mm)	Clearance In. (mm)	Thrust Bearing	Crankshaft End Play In. (mm)	Journal Diam. In. (mm)	Clearance In. (mm)	Side Play In. (mm)
2393 cc & 2753 cc	2.1631-2.1636 (54.942-54.955)	.0008-.0026 (.020-.066)	Center	.002-.007 (.05-.18)	1.9670-1.9675 (49.961-49.974)	.0009-.0026 (.024-.066)	.0079-.0118 (.20-.30)

VALVE SPRINGS

Engine	Free Length In. (mm)	PRESSURE Lbs. @ In. (Kg @ mm)	
		Valve Closed	Valve Open
2393 cc & 2753 cc	Inner	27.1@1.378 (12.3@35)	56.2@.965 (25.5@24.5)
	Outer	47@1.575 (21.3@40)	108@1.161 (49@29.5)

VALVE TIMING

Engine	INTAKE		EXHAUST	
	Open (BTDC)	Close (ABDC)	Open (BBDC)	Close (ATDC)
2393 cc	22°	38°	54°	6°
2753 cc	16°	44°	58°	10°

CAMSHAFT

Engine	Journal Diam. In. (mm)	Clearance In. (mm)	Lobe Lift In. (mm)
2393 cc & 2753 cc	1.8878-1.8883 (47.949-47.962)	.0015-.0026 (.038-.067)