

Datsun/Nissan Engines

PICKUP 4-CYLINDER DIESEL

ENGINE CODING

ENGINE IDENTIFICATION

Engine serial number is located on the front right side of the cylinder block below mating surface with head. Diesel engines are identified by the code number SD22.

ENGINE & CYLINDER HEAD

ENGINE

NOTE: Remove engine and transmission as a unit. Engine can then be separated from transmission assembly.

Removal

1) Disconnect battery ground cable, drain engine coolant, transmission, and crankcase. Mark hood and hinges for reassembly, then remove hood. Remove all hoses and tubes to air cleaner, then remove air cleaner. Disconnect all engine-to-chassis cables, hoses and wires.

2) Remove transmission shift linkage. Detach rubber boot, remove nut from shift lever and remove shift lever. Remove clutch operating cylinder. Remove radiator hoses, shroud, and radiator. Disconnect speedometer cable and all switch wires on transmission case. Remove parking brake cable.

3) Mark for reassembly, and remove propeller shaft. Remove front exhaust pipe. Plug end of transmission. Attach a lifting hoist to engine, and raise enough to take weight off engine mounts. Remove front and rear engine mounting bolts.

4) Turn steering all the way left or right so that suspension center link clears oil pan. Pull engine forward, and carefully remove engine and transmission as an assembly.

Installation

Replace any rubber engine mounts showing signs of deterioration or separation. Ensure proper placement of all engine mountings. Reverse removal procedures to complete installation.

CYLINDER HEAD

Removal

1) Disconnect battery ground cable. Drain cooling system. Remove all hoses and ducts from air cleaner, then remove air cleaner. Remove injection pump timer cover and injection pump timer. Remove fuel injection pump, injection tubes, and nozzle assemblies. Remove rocker cover and alternator.

2) Remove drive belts, fan, and water pump. Disconnect all hoses and vacuum lines from intake manifold to cylinder head or block. Remove intake and exhaust manifolds. Remove thermostat housing, oil filter, and oil cooler assembly.

3) Remove rocker shaft assembly. Remove push rods, and keep in correct order for installation. Remove cylinder head bolts, loosening in several steps in reverse order of tightening sequence. See Fig. 1. Remove cylinder head.

Installation

1) Ensure that mating surfaces of cylinder block and head are clean. Install cylinder head and new gasket with new rubber "O" rings in water and oil passages. Use no sealer.

2) Insert head bolts, and tighten (in sequence shown) in at least 2 steps. Install push rods in same position as before, twisting the rod to ensure proper seating in lifter. Install rocker shaft. Tighten shaft bolts in 2 or 3 steps starting from the center and working out. Fully loosen rocker arm adjusting screws.

Fig. 1: Cylinder Head Tightening Sequence

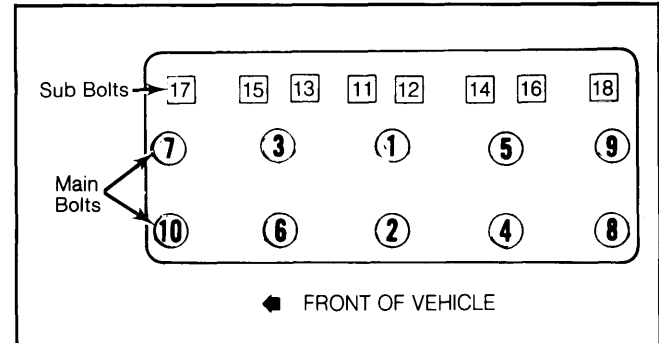

Remove in Reverse Order.

3) Reverse removal procedure to complete installation. Adjust valves. After engine is warmed up, recheck head bolt torque.

CAMSHAFT

CAMSHAFT

NOTE: Procedure must be performed with engine removed from vehicle.

Removal

Remove cylinder head as outlined in previous section. Remove crank pulley and engine front cover. Remove oil pan and oil pump. Remove camshaft locating plate and, with engine inverted on stand, carefully remove camshaft.

Installation

Install camshaft carefully to avoid damaging cam bearings. Install remaining components in reverse of removal procedure, and tighten all nuts and bolts.

CAMSHAFT BEARINGS

Measure inner diameter of camshaft bearing and outer diameter of camshaft journal. If wear or damage is excessive, replace bearings.

Fig. 2: Crankshaft Gear Installation

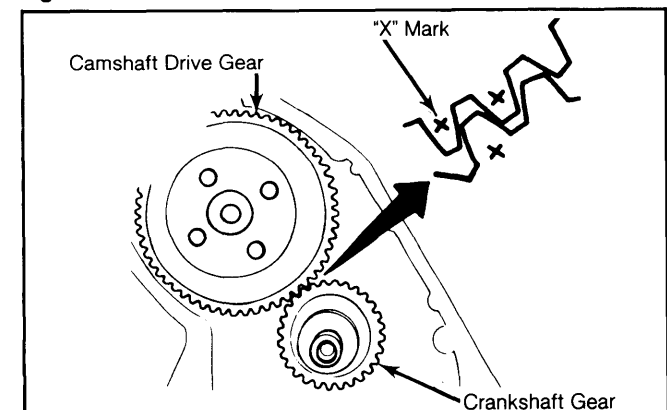

PICKUP 4-CYLINDER DIESEL (Cont.)

ENGINE FRONT COVER

Removal

To remove cover, follow camshaft removal procedures, and then remove crankshaft gear. Remove 3 front cover retaining bolts, and remove front cover.

Installation

Always use new gasket and oil seal when replacing front cover. Apply sealer to gasket, and reverse removal procedures to install.

NOTE: When replacing crankshaft gear, be sure to align the "X" mark on the gear between the 2 "X" marks on the camshaft gear.

VALVES

VALVE ARRANGEMENT

E-I-I-E-E-I-I-E (Front-to-rear).

VALVES

Removal

Remove cylinder head from engine block. Remove glow plugs. Remove valves using valve spring compressor (ST12070000). Remove valve stem oil seals. Keep disassembled parts in order. Check for worn or damaged valves. Replace as needed.

Installation

Always use new valve stem oil seals when valves are removed. Install valves and valve components, using valve spring compressor. Make sure that the valve spring is installed with close coiled end (painted yellow) against cylinder head.

VALVE GUIDE SERVICE

1) Replaceable valve guides are not used in this engine. Measure clearance between valve stem and valve stem hole in head with micrometer and hole gauge. Check diameter of valve stem in three places: top, bottom, and center.

2) Insert hole gauge in valve stem hole, and measure at center. Subtract highest reading of valve stem diameter from valve stem hole to obtain clearance. If clearance exceeds maximum limits of .006" (.15 mm) for the intake valves or .008" (.20 mm) for the exhaust valves, oversize valves should be used and the valve stem holes reamed out to correct specifications.

VALVE STEM SPECIFICATIONS

Stem Size In. (mm)	¹ Stem Diameter In. (mm)
Intake	
Standard3138-.3134 (4.970-7.985)
.008 (.2) O/S3217-.3222 (8.170-8.185)
.016 (.4) O/S3295-.3301 (8.370-8.385)
Exhaust	
Standard ¹3128-.3134 (7.945-7.960)
.008 (.2) O/S3207-.3213 (8.145-8.160)
.016 (.4) O/S3285-.3291 (8.345-8.360)

¹ — Valve guide hole dimension should be between the stem diameter and .006" (.015 mm) greater.

VALVE SEAT INSERTS

1) Check valve seats for pitting or uneven wear at valve contact area. Reface seat if needed. Oversize exhaust valve seats of .008" (.2 mm) and .016" (.4 mm) are available.

2) To remove old inserts, use special seat removing tool (ST10830000). Place new valve seats on dry ice for about 5 minutes to cool. Heat cylinder head to about 175°F (80°C), and install valve seats on head with tool (ST10820000). DO NOT touch valve seats with bare hands while cold.

3) Using a punch and hammer, secure new seat to head in at least 5 places. Make sure seat is punched in a new part of the head, not over previous marks.

Fig. 3: Installing Valve Seat

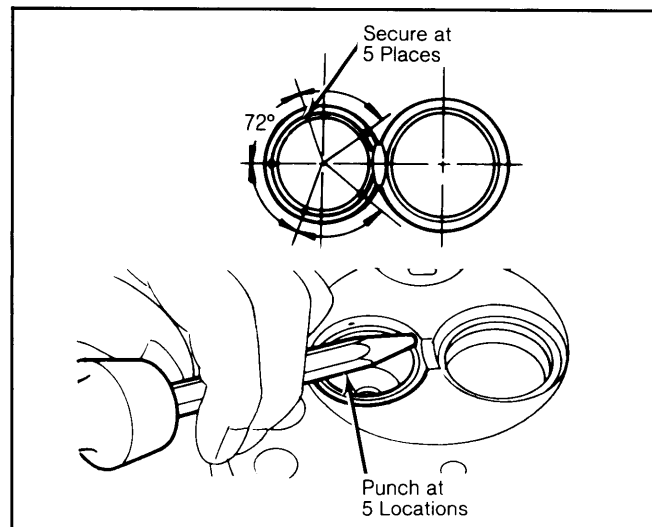

VALVE SPRING INSTALLED HEIGHT

With valves closed, spring height should be 1.525" (39 mm). See specification chart for pressure with valves open or closed.

VALVE ADJUSTMENT

NOTE: Valves should be adjusted with engine at normal operating temperature.

With No. 1 cylinder at TDC on compression stroke, set clearances on No. 1 and No. 3 exhaust valves and No. 1 and No. 2 intake valves. Bring No. 4 cylinder to TDC on compression stroke, and adjust remaining valves. Clearance should be .014" (.35 mm) on all valves, intake and exhaust.

PISTONS, PINS & RINGS

PISTON & ROD ASSEMBLY

Removal

Remove connecting rod nuts and bearing caps. Push piston and rod assembly out top of cylinder, using care not to damage any bearing surface. Retain all components in proper order for reassembly.

Datsun/Nissan Engines

PICKUP 4-CYLINDER DIESEL (Cont.)

Installation

1) Check connecting rods for cracking, bending or twisting. Replace as needed. Reassemble piston and rod assembly so that the combustion chamber on the piston is opposite the matching marks on the connecting rod big end.

2) If replacement rods are used, which have no matching marks, install so that the slight offset of the rod, .06" (.15 mm), is toward the rear of the engine on cylinders No. 1 and 3, and toward the front of the engine on cylinders No. 2 and 4.

Fig. 4: Piston and Rod Assembly Installation Features

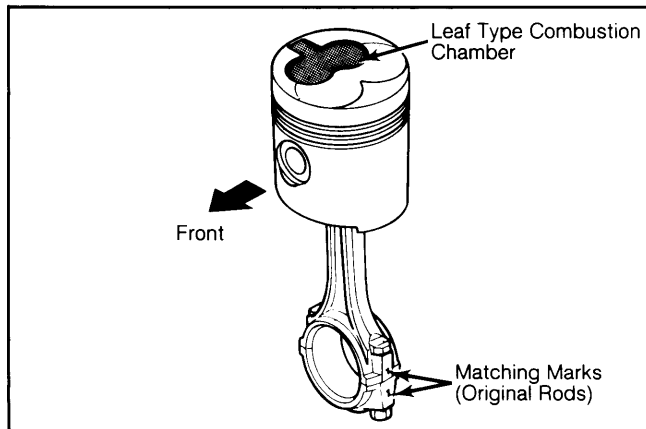

3) Install piston assemblies on original journal with combustion chamber toward right side of cylinder block. Tighten connecting rod nuts, and check rod side play.

FITTING PISTONS

1) Measure cylinder bores for wear or taper at top, bottom, and middle on thrust face and at 90° to thrust face. If excessive wear is found, replace cylinder liner. Check amount of liner projection from each cylinder. There should be less than .0020" (.05 mm) variation between cylinders.

2) Measure piston diameter 2.76" (70 mm) from top of piston. If diameter exceeds 3.264-3.266" (82.915-82.955 mm) by more than .006" (.15 mm), replace piston. After honing cylinder to final fit, install piston.

3) Check rod side clearance. If beyond .004-.008" (.1-.2 mm), replace connecting rod. Measure piston ring end gap and side clearance, and replace as necessary. Install rings on pistons with end gaps 180° apart and so no end gap is in line with thrust face. Install rings with top mark facing upward.

Fig. 5: Installation Order of Piston Rings

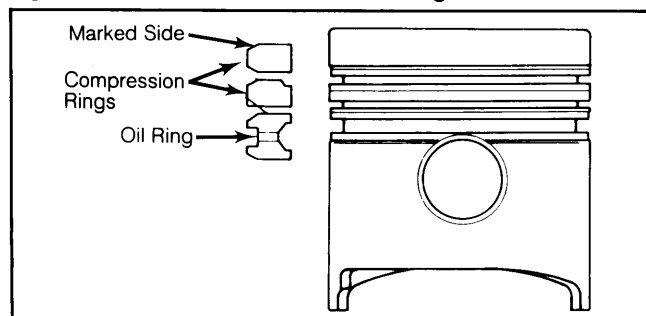

PISTON PINS

Piston pin is a full floating type. Clearance between piston and pin should be less than .0001" (.003 mm). If beyond this limit, replace piston and pin. To assemble piston, pin, and connecting rod, immerse in oil bath at 175°F (80°C), and push in pin. Remove from oil, and install snap rings.

CRANKSHAFT MAIN & CONNECTING ROD BEARINGS

CRANKSHAFT

Removal

1) With engine removed from vehicle, remove cylinder head and camshaft as previously outlined. Remove valve lifters, and keep in correct order. Remove camshaft gear and engine front plate.

2) Remove 2 oil jet bolts located on bottom right side of engine between 1st and 2nd main caps. Remove oil jet.

3) Remove piston/rod assemblies and main bearing caps. Lift out crankshaft. Use puller tool (ST16660000) to remove rear main bearing cap.

Fig. 6: Rear Main Bearing Cap Removal

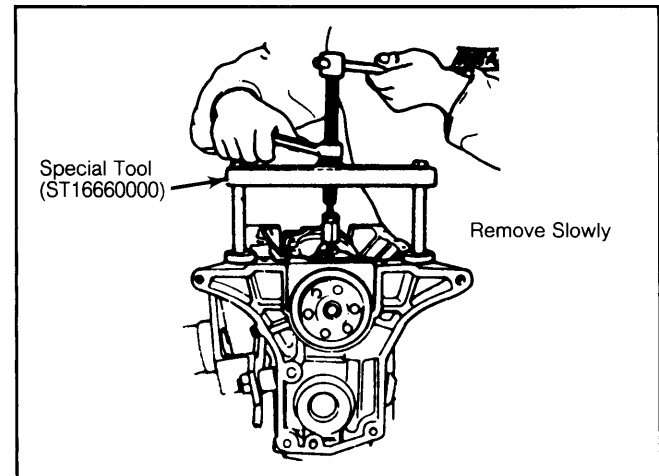

Inspection

1) Check all bearing journals for scoring, excessive wear, cracks or plugged oil passages. Taper and out-of-round on all journals must not exceed .0004" (.01 mm).

2) Check crankshaft for bend using dial indicator at center journal of crankshaft. If bend exceeds .004" (.1 mm) on dial, replace crankshaft.

3) Check main driveshaft pilot bearing at rear of crankshaft for wear or damage, and replace if necessary.

Installation

1) Install main bearing halves to engine block ensuring that all bearings are on correct journal. All upper bearings have oil grooves and are not interchangeable with the lower bearing halves.

2) Install rear oil seals on main bearing cap and cylinder block so that they extend .020" (.5 mm) beyond block and bearing cap. Coat seal with grease

PICKUP 4-CYLINDER DIESEL (Cont.)

where crankshaft will make contact. Apply oil to main bearing surfaces, and install crankshaft. Install main bearing caps with "F" mark towards front of engine.

3) Apply sealer to rear main bearing cap at point where cap contacts cylinder block. Install cap by aligning the marks on cylinder block and main cap. Tighten main caps in several steps, starting from center and working out. Ensure smooth crank rotation. Install crankshaft thrust washer at center journal with oil groove facing away from cap.

Fig. 7: Rear Oil Seal Installation

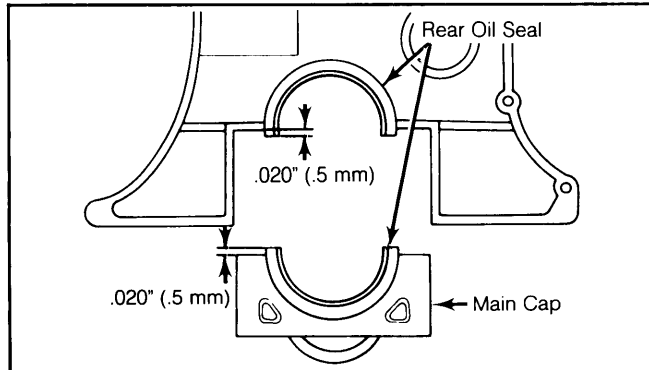

Coat seal with grease where crankshaft will make contact.

4) Install rear main cap side oil seal after coating with sealant. Install with groove in seal toward center, and leave seal protruding from block .020" (.5 mm).

5) Measure crankshaft end play. If not to specification, replace thrust washer. Thrust washers are available in .008" (.2 mm) and .016" (.4 mm) oversize. Install remaining components in reverse of removal procedure.

Fig. 8: Thrust Washer Installation

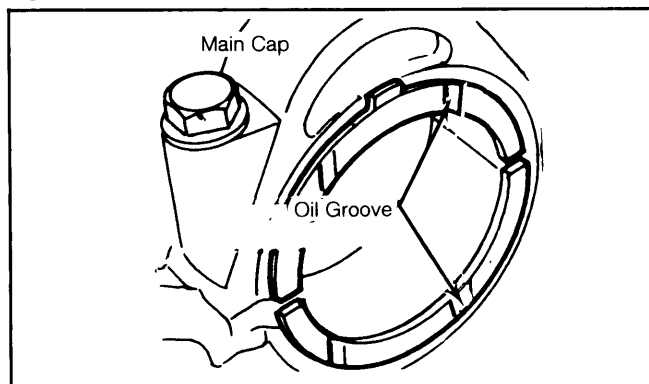

NOTE: Make sure oil holes in oil jet are properly aligned.

MAIN BEARINGS

1) Check all bearings for scoring or wear, and replace if damage is found. Clean oil from crankshaft, and place a strip of Plastigage on crankshaft journal. Install main bearing cap with bearing installed, and tighten to specifications.

NOTE: Plastigage should run parallel with crankshaft and not block oil hole. Do not turn crankshaft while Plastigage is inserted.

2) Remove cap, and measure width of Plastigage at widest point using gauge provided. If clearance is not to specifications, replace bearings. Bearings are available in undersizes of .01" (.25 mm), .03" (.75 mm) and .04" (1.00 mm).

Fig. 9: Oil Jet Installation

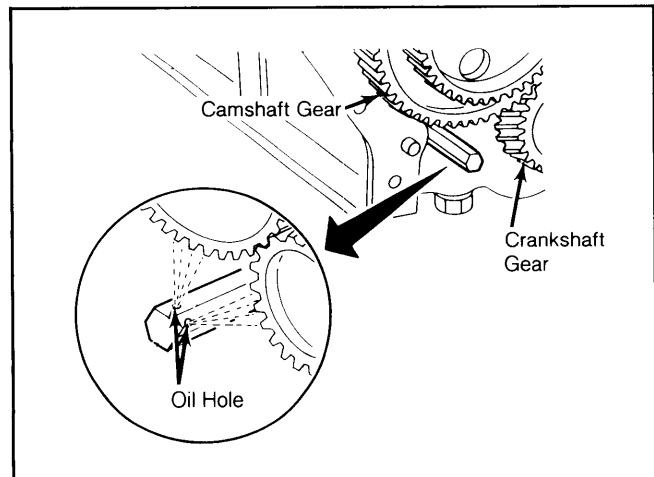

CONNECTING ROD BEARINGS

1) Check connecting rod bearings in same manner as main bearings using Plastigage. Tighten connecting rod caps to specifications.

2) Bearings are available in undersizes of .01" (.25 mm), .02" (.50 mm), .03" (.75 mm) and .04" (1.00 mm). Check for clearance of .001-.004" (.035-.093 mm) when installing new bearings. Maximum wear limit for old bearings is .006" (.15 mm).

ENGINE OILING

CRANKCASE CAPACITY

6.5 qts. (6.2L) with filter.

OIL FILTER

Full-flow, disposable cartridge.

OIL PRESSURE

45-55 psi (3.1-3.7 kg/cm²).

ENGINE OILING SYSTEM

Oil drawn from pan passes through screen to oil pump and is delivered to oil filter, oil cooler, and main oil gallery. Main oil gallery supplies oil to crankshaft main bearings and drilled passages in crankshaft.

Oil sprayed from oil jets lubricates drive gear assembly and cylinders and piston pins. Oil from main gallery lubricates injection pump, vacuum pump, camshaft, and camshaft bearings. Valve rocker mechanism is lubricated through rocker shaft to rocker arms, down push rods to lifters.

OIL PUMP

Removal

1) Oil pump is located at bottom of engine, enclosed by oil pan. Pump is driven by helical gear on camshaft. Remove oil filter, oil pipe, and oil cooler assembly.

Datsun/Nissan Engines

PICKUP 4-CYLINDER DIESEL (Cont.)

2) Remove cooler support and oil pump drive spindle. Drain crankcase, remove engine undercover and front suspension crossmember.

3) Remove oil pan bolts and, with steering wheel all the way right or left, remove pan. Remove oil pump assembly.

Inspection

Disassemble oil pump, and clean all parts thoroughly in clean solvent. Inspect for signs of unusual wear or damage. Check all clearances. Pump is serviced as an assembly only. Replace pump if any part is worn or damaged.

OIL PUMP SPECIFICATIONS

Application	¹ Clearance In. (mm)
Gear Side Clearance (Gear to Bottom Cover)006 (.15)
Gear Tooth Clearance (Tooth to Body)01 (.25)
Gear Backlash02 (.50)
Shaft Ends to Bottom Cover020 (.50)

¹ — Wear limit specifications given.

Installation

Reverse removal procedure to install, ensuring that the drive spindle aligns properly with the camshaft drive gear and drive shaft groove. Install support with new oil seal. Oil hole in support should face cylinder block.

ENGINE COOLING

THERMOSTAT

Thermostat opens at 180°F (82°C), and is fully open at 203°F (95°C).

RADIATOR CAP

13 psi (.9 kg/cm²).

COOLING SYSTEM CAPACITY

10 qts. (9.5L).

WATER PUMP

1) Centrifugal type pump with aluminum body. To remove, drain cooling system, and remove radiator shroud, fan, belts, and pulley.

2) Disconnect coolant hose to thermostat housing, loosen water pump retaining bolts, and remove pump. Reverse removal procedures to install. Always use a new gasket.

TIGHTENING SPECIFICATIONS

Application	Ft. Lbs. (N.m)
Camshaft Gear	33-36 (45-49)
Connecting Rod Cap Nuts	38-41 (52-56)
Crankshaft Pulley	217-239 (295-325)
Cylinder Head	
Sub Bolt	36-47 (49-64)
Main Bolt	87-108 (118-147)
Flywheel	33-36 (45-49)
Injection Pump Nut	14-18 (19-25)
Intake & Exhaust Manifolds	11-13 (15-18)
Main Bearing Cap Nuts	123-127 (167-172)
Oil Jet	22-29 (30-39)
Rocker Pivot Lock Nuts	14-18 (19-25)
Rocker Shaft	14-18 (19-25)

INCH Lbs. (N.m)

Front Cover Bolts	
6 mm Bolts	35-52 (4-6)
8 mm Bolts	84-108 (10-12)
Oil Pump Mounting Bolt	108-168 (12-19)
Oil Cooler Mounting Bolt	84-108 (10-12)

ENGINE SPECIFICATIONS

GENERAL SPECIFICATIONS

Year	Displacement		Fuel System	HP@RPM	Torque Ft. Lbs.@RPM	Compr. Ratio	Bore		Stroke	
	Cu. In.	cc					In.	mm	In.	mm
1982 Pickup	132	2164	Fuel Inj.	21.6:1	3.27	83	3.94	100

VALVES

Engine Size & Valve	Head Diam. In. (mm)	Face Angle	Seat Angle	Seat Width In. (mm)	Stem Diameter In. (mm)	Stem Clearance In. (mm)	Valve Lift In. (mm)
2164 cc Intake	1.492-1.500 (37.9--38.1)	45°	89°3138-.3144 (7.970-7.985)	.0006-.0018 (.015-.045)
Exhaust	1.256-1.264 (31.9-32.1)	45°	89°3128-.3134 (7.945-7.960)	.0016-.0028 (.04-.07)

Datsun/Nissan Engines

6-113

PICKUP 4-CYLINDER DIESEL (Cont.)

ENGINE SPECIFICATIONS (Cont.)

PISTONS, PINS, RINGS

Engine	PISTONS	PINS		RINGS		
	Clearance In. (mm)	Piston Fit In. (mm)	Rod Fit In. (mm)	Ring No.	End Gap In. (mm)	Side Clearance In. (mm)
2164 cc	.0016-.0043 (.04-.11)	.0-.0001 (.0-.003)	.0010-.0018 ¹ (.025-.045)	No. 1	.0118-.0177 (.030-.045)	.0024-.0039 (.06-.10)
				No. 2	.0079-.0138 (.20-.35)	.0016-.0031 (.04-.08)
				Oil	.0005-.0118 (.15-.30)	.0008-.0024 (.02-.06)

¹ — Interference fit.

CRANKSHAFT MAIN & CONNECTING ROD BEARINGS

Engine	MAIN BEARINGS				CONNECTING ROD BEARINGS		
	Journal Diam. In. (mm)	Clearance In. (mm)	Thrust Bearing	Crankshaft End Play In. (mm)	Journal Diam. In. (mm)	Clearance In. (mm)	Side Play In. (mm)
2164 cc	2.7916-2.7921 (70.907-70.920)	.0014-.0037 (.035-.093)	¹	.002-.006 (.06-.14)	2.0832-2.0837 (52.913-52.926)	.0014-.0037 (.035-.087)	.004-.008 (.10-.20)

¹ — Utilizes thrust washer on No. 3 crank journal.

VALVE SPRINGS

Engine	Free Length In. (mm)	PRESSURE Lbs. @ In. (Kg @ mm)	
		Valve Closed	Valve Open
2164 cc	1.976 (50.20)	1.535@66 (39@30)	1.197@134.7 (30.4@61.1)

CAMSHAFT

Engine	Journal Diam. In. (mm)	Clearance In. (mm)	Lobe Lift In. (mm)
2164 cc Front	1.7887-1.7892 (45.434-45.447)	.0009-.0040 (.024-.102)
Middle	1.7282-1.7287 (43.897-43.910)	.0015-.0045 (.037-.115)
Rear	1.6228-1.6233 (41.218-41.231)	.0009-.0040 (.024-.102)

VALVE TIMING

Engine	INTAKE		EXHAUST	
	Open (BTDC)	Close (ABDC)	Open (BBDC)	Close (ATDC)
2164 cc	28°	67°	67°	28°