

## 2000 cc 4-CYLINDER

### ENGINE CODING

#### ENGINE IDENTIFICATION

Vehicle identification and engine information is stamped on model plate at right rear corner of engine compartment. The last digit of the vehicle identification number indicates engine model. Engine displacement is listed immediately below vehicle identification number on model plate.

#### ENGINE IDENTIFICATION CODE

Engine	Code
2000 cc .....	1

### ENGINE, CYLINDER HEAD & MANIFOLDS

#### ENGINE

##### Removal & Installation

1) Remove hood and disconnect battery. Drain cooling system and crankcase. Disconnect hoses from air cleaner and remove air cleaner assembly. Disconnect wiring from distributor, alternator and ignition coil. Disconnect engine ground wire from right side of engine.

2) Disconnect connectors from oil pressure switch, water temperature switch, slow fuel cut valve solenoid and water thermo switch. Disconnect wiring and battery cable from starter. Disconnect throttle linkage, choke cable and fuel lines from carburetor.

3) Disconnect vacuum tube of power brake unit from intake manifold. Disconnect all other vacuum hoses running between engine and engine compartment components. Disconnect heater hoses from intake manifold. Disconnect air hose from air control valve.

4) Disconnect radiator hoses from radiator and remove radiator. Remove exhaust pipe bracket from transmission. Disconnect exhaust pipe from exhaust manifold. Remove starter. Support transmission, then remove transmission-to-engine bolts.

5) Connect a lifting chain and engine hoist to engine. Disconnect engine mounts. Separate engine from transmission. Lift engine from vehicle. To install, reverse removal procedure.

#### INTAKE MANIFOLD

##### Removal

1) Drain cooling system. Remove air cleaner assembly and accelerator linkage. Disconnect fuel line from carburetor. Label and disconnect all vacuum lines and electrical wiring from intake manifold and carburetor. Disconnect heater and by-pass hoses.

2) Disconnect air hoses and vacuum lines at air by-pass valve and remove valve. Disconnect pipe from EGR valve. Remove valve and servo diaphragm of throttle position system. Remove EGR valve and pipe. Remove intake manifold and carburetor as an assembly.

##### Installation

To install, reverse removal procedure while noting the following: Clean all gasket surfaces and install a new gasket. Install intake manifold and tighten attaching bolts working from the center of manifold towards each end.

#### EXHAUST MANIFOLD

##### Removal

1) Remove hot air duct. Remove spark plug wires. Remove air injection pipes (or nozzle) from exhaust manifold. Remove upper and lower heat insulators.

2) Disconnect EGR pipe. Remove exhaust pipe bracket from transmission. Disconnect exhaust pipe at manifold. Remove exhaust manifold.

##### Installation

To install, reverse removal procedure using a new gasket. Apply a light coat of graphite grease to exhaust manifold mating surfaces.

#### CYLINDER HEAD

##### Removal

1) Drain cooling system. Remove air cleaner assembly. Remove exhaust manifold. Disconnect throttle linkage and choke cable from carburetor. Disconnect fuel lines from carburetor.

2) Disconnect EGR pipe from EGR valve. Label and disconnect all electrical wiring, vacuum hoses and coolant hoses from cylinder head, intake manifold and carburetor.

3) Remove water pump. Remove high-tension lead and vacuum hose from distributor. Rotate crankshaft until No. 1 piston is on TDC at end of compression stroke.

4) Remove rocker arm cover. Remove distributor with plug wires. Remove timing chain tensioner cover. Using adjustment procedures explained in Timing Chain & Sprockets, compress timing chain tensioner to relieve tension on timing chain.

5) Remove nut, washer and distributor gear from camshaft. Remove spacer from camshaft. Remove lower front head bolt below camshaft sprocket.

6) Remove cylinder head bolts. Remove rocker arm assembly. Separate camshaft and sprocket. Do not allow chain to separate from sprocket.

7) Rest camshaft sprocket and chain on top of chain guide strip and chain damper. Remove cylinder head and intake manifold assembly.

##### Installation

1) Clean all gasket surfaces and use new gaskets upon installation. Install cylinder head and tighten bolts in sequence. See Fig. 1.

2) Retighten head bolts after engine has been warmed to normal operating temperature. Install remaining components in reverse order of removal. Adjust valves.

Fig. 1: Cylinder Head Tightening Sequence

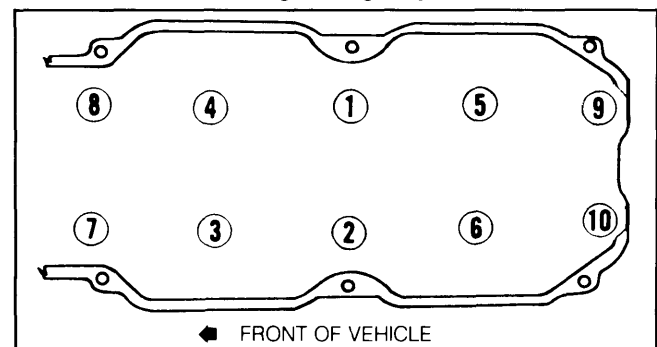

Tighten head bolts with engine cold, then retighten after engine has reached operating temperature.

# Courier Engines

## 2000 cc 4-CYLINDER (Cont.)

### CAMSHAFT

#### ENGINE FRONT COVER

##### Removal

1) Drain cooling system. Disconnect upper radiator hose at engine and lower hose at radiator. Remove fan. Remove radiator.

2) Remove drive belts, crankshaft pulley and water pump. Remove the cylinder head-to-front cover bolt. Remove splash shield under engine.

3) Remove oil pan. Remove alternator bracket from engine and position alternator and bracket aside. Remove air pump and position aside.

4) Remove steel tube bolts and tube from front of engine. Remove front cover attaching bolts and remove front cover.

##### Installation

Clean gasket mating surfaces. Using new gaskets, install front cover and remaining components.

#### FRONT COVER OIL SEAL

**NOTE:** Using special seal remover/installer tools noted below, front cover oil seal can be replaced without removing front cover from vehicle.

##### Removal

Drain cooling system and remove radiator. Remove drive belts from crankshaft pulley. Remove crankshaft pulley. Using seal removing tool (T72J-6700), remove oil seal from front cover.

##### Installation

Using seal installing tool (T72J-6700-A), press front cover oil seal into place. Lubricate oil seal lips with engine oil. Install remaining components in reverse order of removal.

### TIMING CHAIN & SPROCKETS

#### Checking for Stretch

1) Remove crankshaft pulley and water pump. Remove cover from timing chain tensioner. Adjust timing chain tension as explained in Timing Chain Tension Adjustment.

2) Try inserting a 3/8" drill bit between tensioner housing and rear face of snubber. If drill bit can be inserted between tensioner housing and snubber, replace timing chain.

##### Removal

1) Remove cylinder head and front cover. Compress and remove timing chain tensioner. Loosen timing chain guide strip bolts. Remove oil slinger.

2) Straighten lock tab on washer and remove oil pump sprocket attaching nut. Remove oil pump sprocket and chain as an assembly. Remove timing chain, crankshaft sprockets and camshaft sprocket.

##### Installation

1) Position No. 1 piston on TDC at end of compression stroke. Keyway in crankshaft should be straight up. DO NOT allow crankshaft to move.

2) Install crankshaft sprocket and timing chain to crankshaft. The 2 nickel plated links on timing chain must be placed on crankshaft sprocket so they straddle timing mark (located opposite keyway groove) on crankshaft sprocket. See Fig. 2.

Fig. 2: Timing Chain & Sprocket Alignment

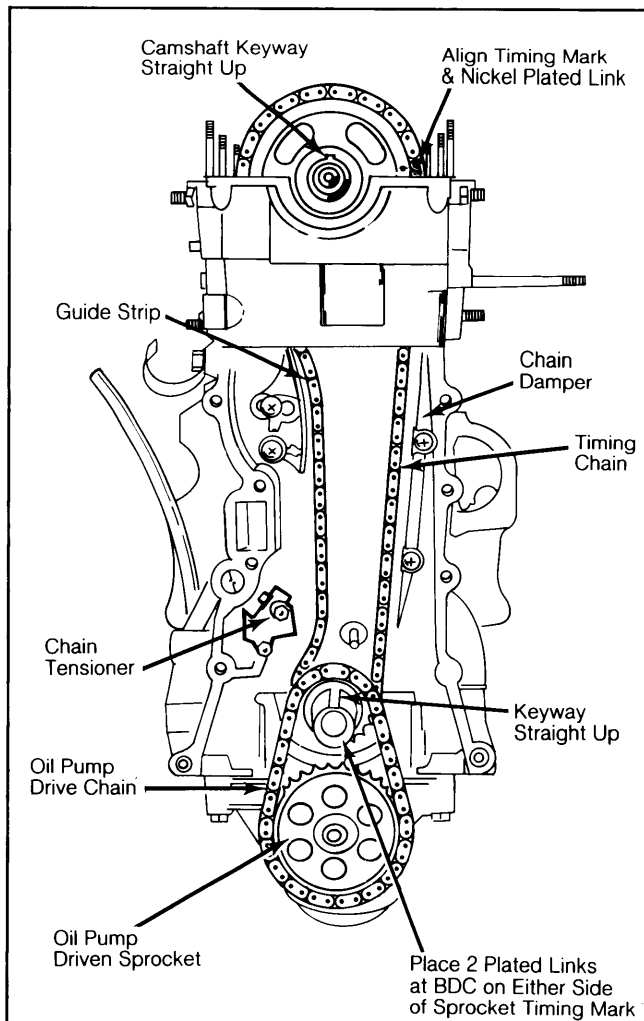

3) Install oil pump drive sprocket and chain on crankshaft, then install oil slinger. Install and tighten oil pump chain and driven sprocket onto oil pump. Check oil pump chain tension adjustment. Refer to Oil Pump installation procedures, in Engine Oiling.

4) Compress rubber snubber on chain tensioner and wedge a screwdriver in the tensioner release mechanism. DO NOT remove screwdriver from tensioner until after chain tension has been adjusted.

5) With tensioner snubber still locked in retracted position, install and tighten timing chain tensioner.

6) Place cylinder head and camshaft onto engine. Do not install rocker arm assembly and head bolts at this time. Position camshaft so keyway faces straight up.

7) Place timing chain around camshaft sprocket so single nickel plated link is aligned with timing mark on camshaft sprocket, then install sprocket on camshaft. See Fig. 2.

8) Install and tighten rocker arm shaft assembly and head bolts. Loosen chain guide strip attaching bolts. Push chain guide strip towards timing chain, then tighten attaching bolts.

## 2000 cc 4-CYLINDER (Cont.)

9) Remove screwdriver from tensioner, allowing snubber to take up chain slack. Install remaining components in reverse order of removal. Retighten cylinder head bolts after engine reaches normal operating temperature, then adjust valves.

### VALVE TIMING

Valve timing procedures are explained in Timing Chain & Sprockets.

### TIMING CHAIN TENSION ADJUSTMENT

#### Front Cover Installed

1) Remove crankshaft pulley and water pump from engine. Remove chain tensioner cover. Turn crankshaft slightly in direction of rotation. Lift the release on the tensioner and fully compress the rubber snubber.

2) Wedge a screwdriver in the tensioner release mechanism so it will not release. See Fig. 3. Unscrew blind plugs from front and rear side of front cover, to gain access to guide strip.

3) Loosen guide strip attaching bolts through front access hole in front cover. See Fig. 3. Insert a screwdriver through access hole in side of front cover, and press in on chain guide strip.

4) Tighten guide strip attaching bolts while pressing in on guide strip. Remove screwdriver from tensioner to allow snubber to take up chain slack.

5) Install blind plugs. Using new gaskets where required, install remaining components in reverse order of removal.

Fig. 3: Adjusting Timing Chain Tension

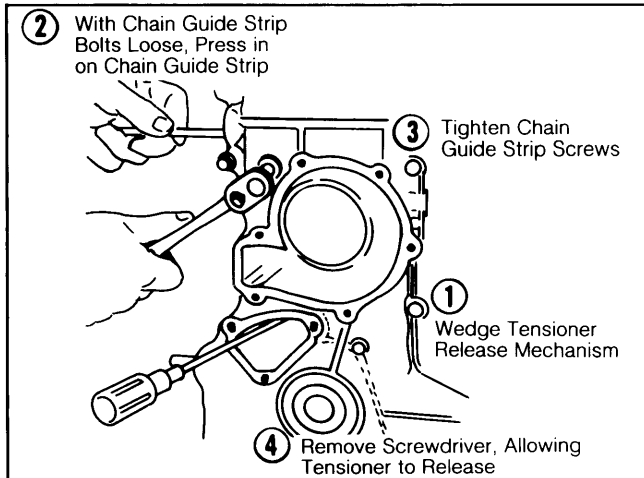

Do not remove screwdriver wedge from tensioner release mechanism until guide strip adjustment is completed.

### CAMSHAFT

#### Removal

1) Remove crankshaft pulley and water pump. Rotate crankshaft to position No. 1 piston on TDC at end of compression stroke. Remove air cleaner and disconnect choke. Remove necessary ignition wiring and vacuum hoses, then remove distributor.

2) Remove rocker arm cover. Remove cover from timing chain tensioner. Lift release mechanism on tensioner and fully compress snubber. Wedge a screwdriver in the tensioner release mechanism to keep spring compressed.

3) Remove nut, washer and distributor gear from camshaft. Remove camshaft sprocket (with chain attached) and rest on guide strip and damper. DO NOT allow chain to separate from sprocket.

4) Remove cylinder head bolts and rocker arm assembly. Remove camshaft from cylinder head.

#### Installation

To install camshaft, reverse removal procedure. Ensure valve timing is correct. Adjust timing chain tension. Adjust valve clearance.

### CAMSHAFT BEARINGS

Remove camshaft and inspect bearings for wear or damage. Use Plastigage method to measure bearing clearance. Replace camshaft bearings which do not meet specifications.

### CAMSHAFT END THRUST

With camshaft installed and properly tightened in cylinder head, use a feeler gauge to measure end thrust. Pull camshaft sprocket forward, then measure end thrust. Replace thrust plate if end thrust exceeds .008" (.20 mm).

### CAM LOBE LIFT

Remove camshaft. Measure distance between major and minor diameters of each cam lobe. See Fig. 4. Difference between the 2 measurements is cam lobe lift. If lobe lift loss on any cam lobe exceeds .008" (.20 mm), replace camshaft.

Fig. 4: Measuring Cam Lobe Lift

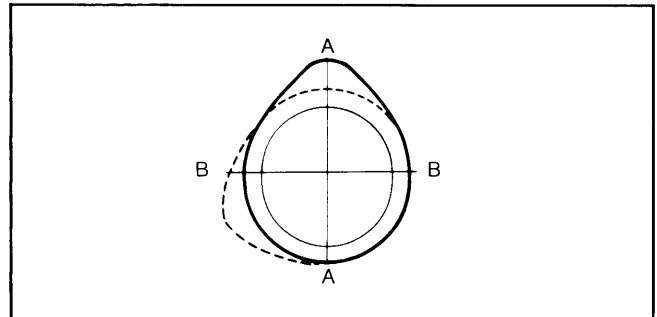

Subtract measurement "B" from "A". Replace camshaft if lobe lift loss on any cam lobe exceeds .008" (.20 mm).

## VALVES

### VALVE ARRANGEMENT

Intake valves (Left side)  
Exhaust valves (Right side)

### ROCKER ARM SHAFT ASSEMBLY

#### Removal

Remove rocker cover. Remove rocker arm shaft attaching bolts evenly and lift off rocker arm shaft assembly. If shafts are disassembled, keep parts in order for reassembly. See Fig. 5.

#### Installation

Heavily lubricate rocker arm shaft components and camshaft with engine oil. To install, reverse removal procedures.

# Courier Engines

## 2000 cc 4-CYLINDER (Cont.)

Fig. 5: Exploded View of Rocker Arm & Shaft Assembly

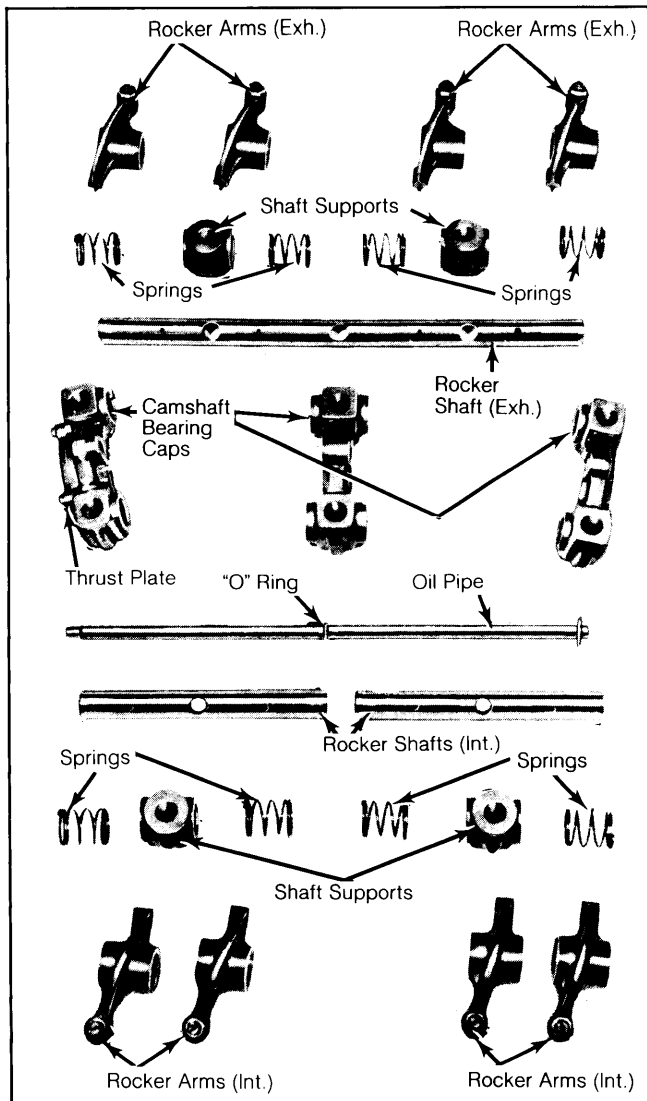

If rocker arm shafts are disassembled, keep parts in order for reassembly.

### VALVE GUIDE SERVICING

#### Removal

Check guides for wear or damage and replace as necessary. Using valve guide remover/installer tool (T72J-6510), drive valve guides out top of cylinder head.

#### Installation

Using guide installing tool, drive new guides into place until ring around guide touches cylinder head. Note that exhaust and intake valve guides are different.

### VALVE STEM OIL SEALS

Remove cylinder head from engine. With valves and springs removed, pull oil seals off valve guides. Install new seals on valve guides with large diameter hole facing cylinder head.

### VALVE SPRINGS

#### Removal

1) With cylinder head removed from engine, proceed as follows: Compress valve springs and remove

retainer locks. Release springs and remove spring retainer, spring, oil seal and valve

2) Identify all valve components for later installation in original positions. Exhaust and intake retainers must be installed in original positions to prevent premature valve failure.

#### Inspection

1) Using valve spring tension tester, check valve spring pressure at specified height. Replace if not within specifications.

2) Measure free length of spring. If not within 3% of specified value, replace spring. Using a steel square and flat surface, check that springs are not more than .056" (1.42 mm) out-of-square.

#### Installation

Lubricate valve stems, valve guide and oil seals with engine oil. Apply Lubriplate to valve tips. Install in reverse order of removal procedures.

### VALVE CLEARANCE ADJUSTMENT

1) Adjust valves with engine at normal operating temperature. Using a feeler gauge, check valve clearance between valve tip and rocker arm. Hot valve clearance is .012" (.30 mm).

2) Adjust valves in firing order sequence, with piston of cylinder concerned at TDC of compression stroke.

## PISTONS, PINS & RINGS

### OIL PAN

#### Removal

1) Raise vehicle on hoist and remove splash shield. Drain crankcase. Remove clutch slave cylinder and position aside. Remove engine rear brace attaching bolts and loosen bolts on left side.

2) Remove oil pan attaching nuts and bolts. Lower oil pan from engine and lay on crossmember. Remove oil pump pick-up tube. Remove oil pan from vehicle.

#### Installation

To install, reverse removal procedure while noting the following: Clean all gasket surfaces and use new gasket upon installation. Ensure that oil pump pick-up tube and screen are clean before installing.

### PISTON & ROD ASSEMBLY

#### Removal

1) With cylinder head and oil pan removed, remove oil pump. Rotate crankshaft until piston to be removed is at bottom of travel.

2) Place a cloth on piston to collect cuttings. Using a ridge reamer, remove any ridge or deposits from upper end of cylinder. Do not cut into ring travel area in excess of 1/32".

3) Make sure connecting rod caps are marked so they may be replaced in their original positions, then remove rod caps. Push piston and rod assembly out top of cylinder block. Take care not to damage bearing journal.

#### Installation

1) Oil piston rings, pistons and cylinder walls with engine oil. With rings properly spaced, install ring compressor onto piston. Install piston and rod assembly into its original bore.

## 2000 cc 4-CYLINDER (Cont.)

2) Make sure connecting rod marks are facing left side of engine and "F" mark on piston is facing forward. See Fig. 7. Install rod caps and tighten rod bolts.

### FITTING PISTONS

Determine piston-to-cylinder bore clearance. Check cylinder for out-of-round and taper. Fit new pistons if necessary. Pistons are available in .010", .020", .030" and .040" oversizes.

### FITTING RINGS

1) Place rings in cylinder near bottom of bore and measure end gaps. Make sure ring is square in bore. See Fig. 6.

2) Place rings on piston and measure side clearance between ring and its lower land. If lower lands have high steps, replace piston.

3) Place rings on piston with end gaps spaced 120° apart. Ensure that no gap is located on thrust face or pin bore side of piston. Using ring compressor, install piston in proper bore with "F" marking facing forward.

**Fig. 6: Measuring Piston Ring End Gap**

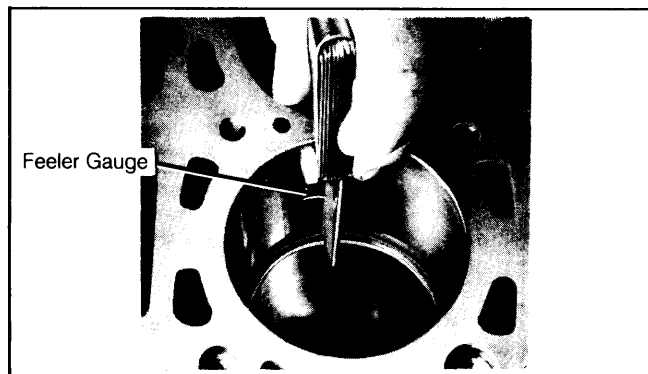

*Piston must be square in cylinder bore.*

### PISTON PIN REPLACEMENT

1) Piston pins are removed using an arbor press, pilots and driver. Measure pin and connecting rod diameters to ensure proper fit.

2) Assemble rod to piston so "F" marking in piston head will face front of engine, and connecting rod cylinder identification number will be on left side of engine. See Fig. 7.

**Fig. 7: Piston-to-Rod Relationship**

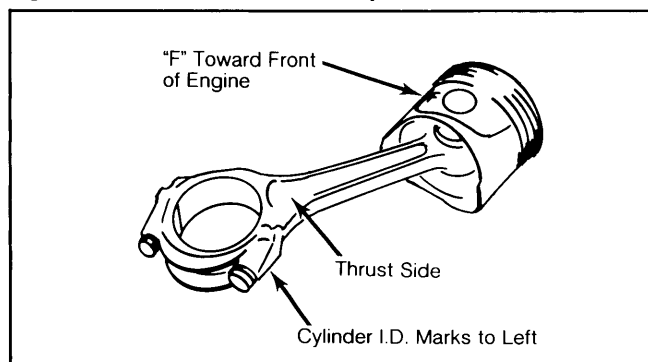

*Ensure numbers on rod and rod cap are installed on same side of rod.*

## CRANKSHAFT MAIN & CONNECTING ROD BEARINGS

### CRANKSHAFT MAIN & CONNECTING ROD BEARINGS

1) With oil pan and oil pump removed, replace bearings 1 at a time while leaving the others securely fastened.

2) Replace bearings if scored, chipped or worn condition exists. If copper base is visible through bearing overlay, replacement is not necessary, provided clearance is within specifications.

3) When installing new bearings, fit bearings to minimum specified clearance. Use Plastigage method to determine bearing clearances. Replacement bearings are available in .010", .020" and .030" undersizes.

4) When replacing rear main bearing, also replace rear main bearing oil seal and rear main cap side seals.

5) If rear main bearing thrust washers are replaced, fit the half of each thrust washer to cylinder block with oil grooved surface facing crankshaft thrust side.

### THRUST BEARING ALIGNMENT

Pry crankshaft endwise and insert a feeler gauge between thrust washers and crankshaft. Install correct thickness thrust washers if measurement is not within specifications. Install new thrust washers with oil grooved surface facing crankshaft thrust side.

### REAR MAIN BEARING OIL SEAL

**NOTE:** If rear main bearing seal replacement is only operation being performed, it can be done in vehicle; however if it is being replaced in conjunction with rear main bearing, engine must be removed.

#### Removal

Remove transmission and clutch assembly. Using an awl, punch two holes in seal and install sheet metal screws in holes. Using pry bars, pry out old seal. Use care to avoid damage to crankshaft.

#### Installation

Coat seal case with engine oil and seal lips with Lubriplate. Using seal installing tool, drive in new seal. Install remaining components.

## ENGINE OILING

### CRANKCASE CAPACITY

Capacity is 4.1 quarts (3.9L) without filter replacement; 4.7 qts. (4.5L) with oil filter replacement.

### NORMAL OIL PRESSURE

Minimum oil pressure at idle is 4.3 psi (.30 kg/cm<sup>2</sup>). At 3000 RPM, oil pressure should be 50-64 psi (3.5-4.5 kg/cm<sup>2</sup>).

### ENGINE OILING SYSTEM

Rotor type oil pump is chain driven by crankshaft. Timing chain is lubricated by oil jet in cylinder block

# Courier Engines

## 2000 cc 4-CYLINDER (Cont.)

and oil holes in slipper head of adjuster. All internal moving parts of engine are lubricated by pressure feed lubrication, oil drainage, or splash method.

### OIL PUMP

#### Removal

Remove oil pan. Remove attaching nut from oil pump sprocket. Remove oil pump attaching bolts. Loosen sprocket from pump and remove oil pump.

#### Disassembly

1) Remove oil inlet tube and gasket from pump. Remove pump cover. Remove inner rotor and shaft assembly, then remove outer rotor.

2) To remove relief valve, remove cotter pin from pump body and pull cap from chamber. Remove spring and plunger.

**NOTE:** The inner rotor and shaft assembly and outer rotor are only replaceable as an assembly.

#### Inspection

1) Check inside of pump housing and rotors for damage or excessive wear. Check mating surface of pump cover for wear. If cover mating surface is worn, scored or grooved, replace cover.

2) With rotor assembly installed in pump housing, use a feeler gauge to measure outer rotor to pump housing clearance. Also, measure clearance between rotor lobes.

3) With rotor assembly installed in pump housing, place a straightedge over rotor assembly and the housing. Insert a feeler gauge between straightedge and rotors to measure rotor end play.

4) Measure drive shaft to housing bearing clearance by measuring OD of the shaft and ID of housing bearing.

#### Reassembly

Using new gaskets and "O" rings, reassemble oil pump in reverse order of disassembly.

### Installation

1) Prime oil pump. Position oil pump driven sprocket to chain. Using new "O" ring between pump and cylinder block mating surface, install and tighten oil pump.

2) Install and tighten pump sprocket. After tightening sprocket nut, be sure to bend over washer to lock nut in place.

3) Check oil pump chain for excessive deflection. See Fig. 8. If deflection exceeds 5/32" (3.97 mm), install adjusting shims between oil pump and cylinder block mating surface.

### OIL PUMP SPECIFICATIONS

Application	Clearance In. (mm)
Outer Rotor-to-Housing Clearance Between	.006-.010 (.152-.254)
Rotor Lobes	.002-.006 (.051-.152)
Rotor End Play	.002-.004 (.051-.102)

## ENGINE COOLING

### THERMOSTAT

Thermostat begins opening at 180°F (82°C), and is fully open at 203°F (95°C).

### COOLANT CAPACITY

Capacity is 7.6 qts. (7.2L)

### RADIATOR CAP

Relief valve opens at 13 psi (.90 kg/cm²).

### WATER PUMP

#### Removal

1) Drain cooling system. Remove lower hose from water pump. Disconnect upper radiator hose at engine and lower hose at radiator. Remove radiator from vehicle.

2) Loosen alternator and air pump adjusting and mounting bolts, then remove drive belts. Remove fan and pulley. Remove crankshaft pulley. Disconnect by-pass hoses from water pump. Remove water pump.

#### Installation

Clean gasket mating surfaces. Using new gasket, install water pump and remaining components in reverse order of removal.

Fig. 8: Measuring Oil Pump Chain Deflection

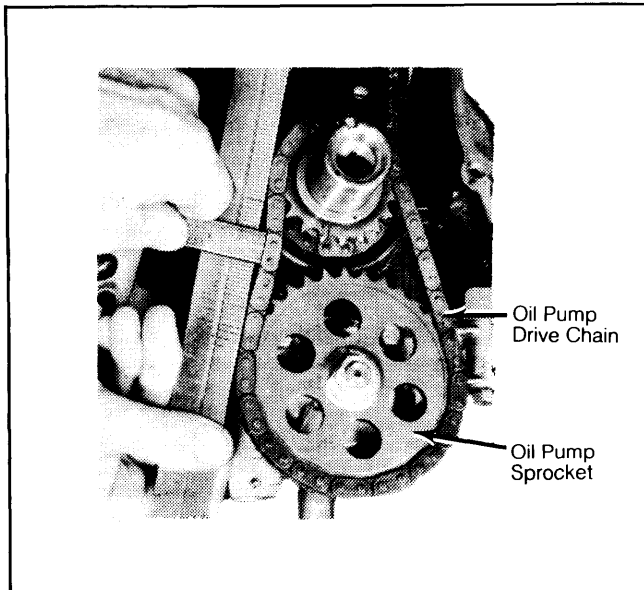

If deflection exceeds 5/32" (3.97 mm), install adjusting shims between pump and cylinder block.

### TIGHTENING SPECIFICATIONS

Application	Ft. Lbs. (N.m)
Camshaft Sprocket	51-58 (69-79)
Connecting Rod Caps	36-40 (49-54)
Cylinder Head	
Step 1 (Cold)	65-69 (88-94)
Step 2 (Hot)	69-72 (94-98)
Exhaust Manifold	16-21 (22-29)
Flywheel	112-118 (152-160)
Intake Manifold	14-20 (19-27)
Main Bearing Caps	61-65 (83-88)
Oil Pump-to-Block	13-20 (18-27)
Oil Pump Sprocket	22-26 (30-35)

# Courier Engines

6-77

## 2000 cc 4-CYLINDER (Cont.)

### ENGINE SPECIFICATIONS

#### GENERAL SPECIFICATIONS

Year	Displacement		Fuel System	HP@RPM	Torque Ft. Lbs.@RPM	Compr. Ratio	Bore		Stroke	
	Cu. In.	cc					In.	mm	In.	mm
1982	120.2	1970	2-Bbl.	.....	.....	8.6:1	3.15	80.0	3.86	96.5

#### VALVES

Engine Size & Valve	Head Diam. In. (mm)	Face Angle	Seat Angle	Seat Width In. (mm)	Stem Diameter In. (mm)	Stem Clearance In. (mm)	Valve Lift In. (mm)
1970 cc Intake	1.6497-1.6575 (41.90-42.10)	45°	45°	.055 (1.397)	.3162-.3168 (8.031-8.047)	.0007-.0021 (.017-.053)	.....
Exhaust	1.2953-1.3031 (32.90-33.09)	45°	45°	.055 (1.397)	.3160-.3168 (8.026-8.047)	.0007-.0023 (.017-.058)	.....

#### PISTONS, PINS, RINGS

Engine	PISTONS	PINS		RINGS		
	Clearance In. (mm)	Piston Fit In. (mm)	Rod Fit In. (mm)	Ring No.	End Gap In. (mm)	Side Clearance In. (mm)
1970 cc	.0014-.0030 (.036-.076)	.0003-.0009 (.008-.023)	.....	1 & 2 Oil	.008-.016 (.20-.40) .012-.035 (.30-.89)	.0011-.0027 <sup>1</sup> (.028-.069) .....

<sup>1</sup> — No. 2 ring side clearance is .0011-.0025" (.028-.064 mm).

#### CRANKSHAFT MAIN & CONNECTING ROD BEARINGS

Engine	MAIN BEARINGS				CONNECTING ROD BEARINGS		
	Journal Diam. In. (mm)	Clearance In. (mm)	Thrust Bearing	Crankshaft End Play In. (mm)	Journal Diam. In. (mm)	Clearance In. (mm)	Side Play In. (mm)
1970 cc	2.4780-2.4786 (62.94-62.95)	.0005-.0024 (.013-.061)	5	.003-.009 (.076-.228)	2.0842-2.0848 (52.938-52.954)	.001-.003 (.025-.076)	.004-.008 (.102-.203)

#### CAMSHAFT

Engine	Journal Diam. In. (mm)	Clearance In. (mm)	Lobe Lift In. (mm)
1970 cc <sup>1</sup> Front & Rear	1.7695-1.7701 (44.945-44.960)	.0007-.0027 (.018-.069)	2
Center	1.7691-1.7697 (44.935-44.950)	.0011-.0031 (.028-.079)	2

#### VALVE SPRINGS

Engine	Free Length In. (mm)	PRESSURE Lbs. @ In. (Kg @ mm)	
		Valve Closed	Valve Open
1970 cc	1.598 (40.59)	.....	48-59@1.36 <sup>1</sup> (22-27@34.5)

<sup>1</sup> — Compressed height as measured in spring tester.

<sup>1</sup> — End play is .001-.007" (.025-.178 mm).

<sup>2</sup> — See procedures in Cam Lobe Lift.