

320i 4-CYLINDER

ENGINE CODING

ENGINE IDENTIFICATION

Engine identification number is located on engine block at left hand side above starter motor.

ENGINE & CYLINDER HEAD

MANUAL TRANSMISSION

Removal

1) Remove all upper transmission-to-engine mounting bolts. Remove exhaust pipe support bracket. Disconnect exhaust pipe at manifold.

2) Install and tighten compressing strap (261012) around front rubber coupling until bolts attaching rubber coupling to transmission output flange can be removed.

3) Detach center bearing bracket from body after removing heat shield to gain access. Pull down on propeller shaft at center bearing to disengage shaft from transmission flange.

4) Remove speedometer cable. Label and disconnect back-up light switch and 4th gear switch. Remove center console from transmission. Engage transmission in reverse gear, then remove selector rod.

5) Remove clutch slave cylinder and hydraulic line support bracket. Support transmission with transmission jack or stand. Remove crossmember. Remove remaining transmission mounting bolts. Remove transmission.

Installation

To install, reverse removal procedure while noting the following: Install clutch slave cylinder with bleeder valve facing downward. When installing propeller shaft, push center bearing bracket forward .08" (2.0 mm) to preload center bearing, then tighten nuts.

AUTOMATIC TRANSMISSION

Removal

1) Remove accelerator cable and detach from bracket. Remove upper transmission-to-engine mounting bolts. Remove oil filler neck and drain oil.

2) Remove exhaust pipe support bracket. Disconnect exhaust pipe at manifold. Remove speedometer cable from transmission. Remove transmission output flange bolts and detach propeller shaft coupling.

3) Remove heat shield to gain access to center support bearing. Remove center bearing bracket. Pull down on propeller shaft at center bearing to disengage shaft from transmission flange.

4) Remove cover from bottom of transmission. Remove drive plate-to-torque converter bolts. Remove transmission oil cooler lines. Support transmission with transmission jack or stand, then remove crossmember.

5) Remove remaining transmission mounting bolts. Lift off side cover from transmission. Insert a bar through side cover hole, and carefully pry transmission and torque converter away from engine.

Installation

To install, reverse removal procedure. Ensure that torque converter is properly positioned on drive plate. When installing propeller shaft, push center bearing bracket forward .08" (2.0 mm) to preload center bearing, then tighten nuts.

ENGINE

Removal

1) Disconnect positive and negative cables from battery. Remove transmission. Drain cooling system and disconnect hoses. Remove oil cooler lines from radiator (if equipped). Remove fan shroud and radiator.

2) If equipped, remove A/C compressor (with hoses connected) and position aside. Remove air cleaner housing. Disconnect fuel feed and return hoses from fuel distributor.

3) Remove hose from charcoal canister. Disconnect ground cable from front axle carrier. Disconnect accelerator cable from throttle valve housing. Label and disconnect all coolant and vacuum hoses from engine.

4) Label and disconnect all electrical and ignition wires between chassis and engine that might interfere with engine removal. Install lifting chain to engine.

5) With engine hoist in place, apply slight supporting tension to engine. Detach left engine mount and upper engine damper. Detach right engine mount. Remove engine from vehicle.

Installation

To install, reverse removal procedure while noting the following: When filling with coolant, set heater control to "WARM" and fill radiator slowly. Bleed cooling system after engine is warm.

CYLINDER HEAD

Removal

1) Disconnect ground cable from battery. Remove air cleaner housing. Remove fuel line from cold start valve. Remove air hose from auxiliary air regulator.

2) Label and disconnect electrical connections at cylinder head and intake manifold that might interfere with cylinder head removal. Be sure to disconnect harness plug in glove box, and pull wiring through hole in engine compartment wall.

3) Drain cooling system. Disconnect all coolant hoses from cylinder head and intake manifold. Label and disconnect all vacuum hoses from intake manifold.

4) Remove cap from ignition coil. Label and disconnect primary ignition wires from coil and distributor.

Fig. 1: Timing Mark Alignment for Setting No. 1 Piston at TDC

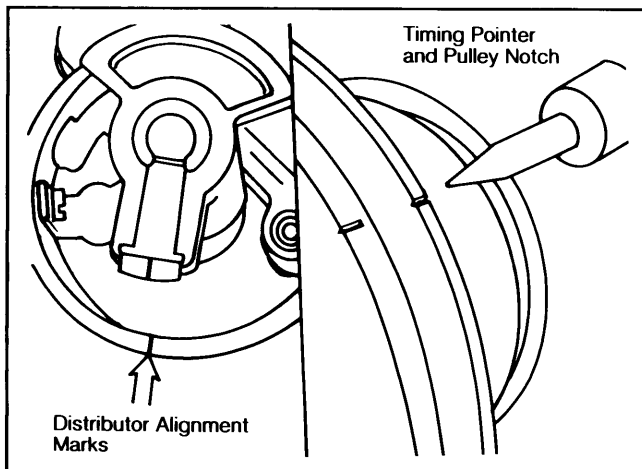

Do not allow crankshaft to move once marks are aligned.

BMW Engines

320i 4-CYLINDER (Cont.)

Remove high tension lead from distributor cap and spark plug wires from spark plugs. Remove distributor cap.

5) Disconnect accelerator cable. Disconnect oil dipstick tube mount. Label and disconnect fuel lines to fuel injectors. Remove rocker cover. Set No. 1 piston at TDC. Align distributor rotor with notch in distributor housing, and timing pointer with notch in damper/pulley. See Fig. 1.

6) Remove upper front cover. Using care (because of strong spring pressure), remove timing chain tensioner plug, spring and piston. Remove 4 camshaft sprocket attaching bolts and remove sprocket.

7) Disconnect exhaust support bracket. Disconnect exhaust pipe from manifold. Remove cylinder head bolts in reverse sequence of tightening. See Fig. 2. Remove cylinder head with intake manifold attached.

Installation

1) Clean all gasket mating surfaces. Measure distance dowel sleeve (installation guide) projects above cylinder head mounting surface. See Fig. 3. Maximum projection should not exceed .197" (5.00 mm).

2) Remove any oil in cylinder head bolt blind holes. Oil in holes may result in incorrect head bolt tightening and possible cylinder head or block damage. Clean cylinder head bolts. Clean threads in block.

Fig. 2: Cylinder Head Tightening Sequence

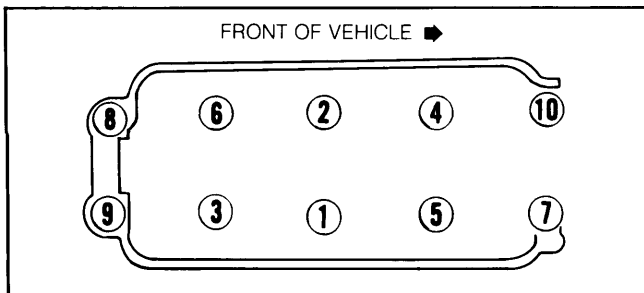

Tighten head bolts in 3 steps, then repeat 3rd step. Retighten head bolts (cold) at 1000 miles.

3) Lubricate head bolt threads and bottom of bolt heads with engine oil. Using new head gasket, install cylinder head. Tighten head bolts in 3 steps, then repeat 3rd step for final tightening. See Fig. 2.

Fig. 3: Measuring Dowel Sleeve Projection Above Cylinder Block

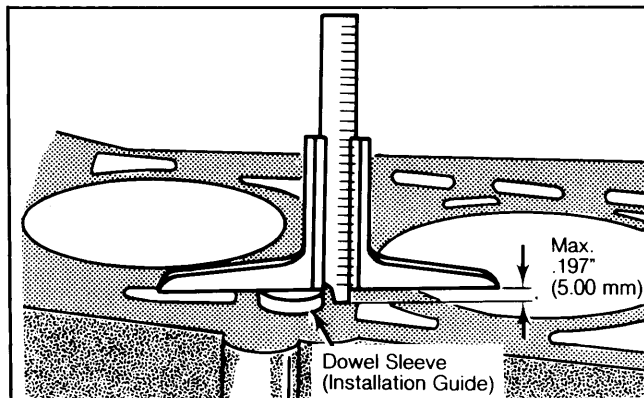

Ensure cylinder block deck surface is clean and free from nicks or burrs.

4) Install remaining components in reverse order of removal. Ensure valve timing is correct. Adjust valves. At 1000 miles, check torque of head bolts with engine cold. If necessary further tighten head bolts.

CAMSHAFT

ENGINE FRONT COVERS

Removal (Upper Cover)

Remove rocker cover. Disconnect air injection pipe from exhaust manifold. Remove upper front cover attaching bolts. Remove, clean and inspect cover.

Installation

1) Fill 2 holes in lower front cover (where it junctions with the cylinder head) with sealing compound. Using a new gasket, install front cover.

2) Install attaching bolts. Loosely tighten attaching bolts to lower front cover. Tighten bolts that attach front cover to cylinder head. Tighten bolts that attach upper front cover to lower front cover last.

Removal (Lower Cover)

1) Disconnect battery ground cable. Remove water pump. Remove upper front cover. Using care (because of strong spring pressure), remove timing chain tensioner plug, spring and piston.

2) Disconnect wires from alternator. Remove alternator, mounting bracket and adjusting bracket.

3) Remove oil filter adapter housing. Remove air pump, mounting bracket and adjusting bracket. Remove lifting eye from lower cover. Remove flywheel cover and lock flywheel in place. Remove damper/pulley.

4) Remove attaching bolts from lower cover and front of oil pan. Loosen remaining oil pan bolts. Carefully separate oil pan gasket from timing case cover with knife blade. Remove lower cover.

Installation

Apply gasket sealer to gaskets. Install lower front cover and remaining components in reverse order of removal. Ensure that chain tensioner take-up land is in oil pocket.

FRONT COVER OIL SEAL

Removal & Installation

1) Remove fan housing from radiator. Loosen alternator and remove drive belt. Remove flywheel cover and lock flywheel in place. Remove damper/pulley. Carefully pry seal from recess in cover.

2) Lubricate seal lip with oil. Use seal installing tool to press in seal flush.

TIMING CHAIN & SPROCKETS

Removal

1) Remove distributor cap. Set No. 1 piston at TDC. Align distributor rotor with notch in distributor housing, and timing pointer with notch in damper/pulley. See Fig. 1. DO NOT allow crankshaft to move.

2) Remove upper and lower timing case covers. Remove camshaft sprocket. Remove circlip and unscrew pivot pin until chain guide rests on cylinder head gasket. Remove timing chain from sprocket and crankshaft.

3) Remove chain guide by pulling down and swinging to the right. Remove chain from guide.

4) If crankshaft sprocket removal is necessary, remove oil pan. Remove oil pump sprocket and drive

320i 4-CYLINDER (Cont.)

chain. Remove Woodruff key from crankshaft. Using a puller, remove crankshaft sprocket.

Installation

1) If removed, crankshaft sprocket must be heated before installing. Install Woodruff key, crankshaft sprocket, oil pump drive chain and oil pump sprocket.

2) Oil pump drive chain has correct tension if chain gives under slight thumb pressure midway between sprockets. Two drive chains are available for tension adjustment. If proper tension cannot be obtained with either of both drive chains, shims are available for installation between oil pump and cylinder block.

3) Install timing chain, camshaft sprocket and remaining components in reverse order of removal. Note that dowel pin bore in camshaft flange must be positioned downward. Notch in camshaft flange must face upward and align with cast tab on cylinder head.

VALVE TIMING

1) Rotate crankshaft to place No. 1 piston on TDC. Timing pointer must align with notch in crankshaft damper/pulley. Distributor rotor must align with notch in housing. See Fig. 1.

2) Position camshaft so that timing notch on camshaft flange is up, and aligns with cast tab on cylinder head. Dowel pin locating hole in camshaft flange must be positioned downward.

3) Install timing chain components. Without moving crankshaft or camshaft, install camshaft sprocket so that it engages in dowel pin locating hole in camshaft flange.

TIMING CHAIN TENSIONER

CAUTION: Timing chain tensioner piston is under high spring pressure. Use care when unscrewing tensioner plug.

Removal & Disassembly

1) Unscrew tensioner plug, being careful of high spring pressure against plug. Remove spring and piston.

2) Remove piston, check valve and metering disc from piston sleeve. See Fig. 4. Clean all parts thoroughly and blow out with compressed air.

Fig. 4: Disassembled View of Tensioner Components

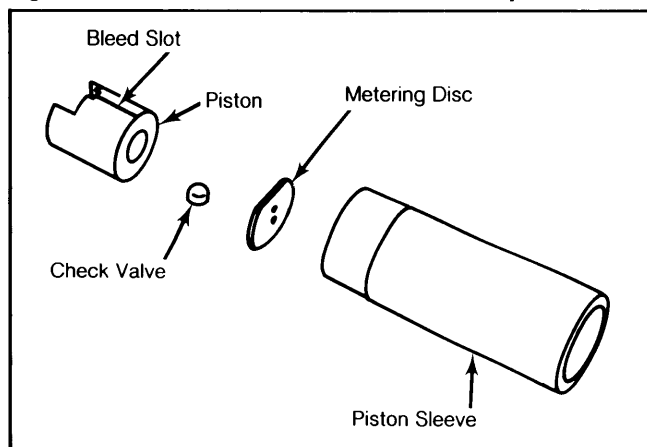

Piston must be purged of air after installing.

Reassembly & Installation

1) Reassemble piston parts in reverse order. Ensure that metering disc does not block bleed slots in piston. Remove rocker cover.

2) Install piston and spring in lower front cover. Tapered end of spring must face tensioner plug. Install plug and lightly tighten. Fill tensioner piston oil pocket (in lower front cover) with engine oil.

3) Piston must be purged of air. Using a screwdriver, move tensioning rail back and forth against piston until oil runs out around tensioner plug threads. Tighten tensioner plug.

CAMSHAFT

Removal

1) Remove cylinder head. Remove distributor from cylinder head. Mount cylinder head assembly in a holding fixture. Remove oil drainage pipe from top of head. Remove cold start valve.

2) Adjust valve clearance to maximum possible to relieve tension on camshaft. Attach compression frame and bracket (11 1 040) to compress rocker arms. Install short end of bracket towards exhaust valve side.

3) Remove thrust plate from cylinder head. Carefully remove camshaft from cylinder head. Leave compression frame tool in place until camshaft has been installed.

Installation

1) When installing camshaft, note the following: After guide plate has been installed, it must be possible to easily rotate the camshaft. Make sure that notch in camshaft flange aligns with cast tab on cylinder head.

2) Adjust valves. Ensure oil drainage pipe seals are properly positioned.

3) Turn rotor counterclockwise about 1 3/8" from notch in distributor housing. Guide distributor drive into mesh with camshaft drive. Make sure rotor aligns with notch in distributor housing. Install remaining components.

CAMSHAFT END THRUST

1) Remove cylinder head. Remove distributor from cylinder head. Mount cylinder head assembly in a holding fixture. Remove oil drainage pipe from top of head. Remove cold start valve.

2) Adjust valve clearance to maximum possible to relieve tension on camshaft. Attach a compression frame and bracket (11 1 040) to compress rocker arms. Install short end of bracket towards exhaust valve side.

3) Insert a feeler gauge between thrust plate and camshaft flange. Maximum end thrust is .005" (.13 mm). Replace worn components as necessary.

VALVES

VALVE ARRANGEMENT

Intake valves (Left side)

Exhaust valves (Right side)

ROCKER ARM SHAFT ASSEMBLY

Removal

1) Remove camshaft. Push back thrust ring and rocker arm and remove rocker shaft circlip. Remove distributor mounting flange.

BMW Engines

320i 4-CYLINDER (Cont.)

2) Drive out rocker shafts from rear of head. Retain all springs, washers, rocker arms and thrust rings in proper order for reassembly.

Installation

1) Install all parts in original locations. Replace worn rocker arms and shafts. Replace rocker arms with loose camshaft contact pads. Use locating pins when installing rocker shafts to align notches for head bolts.

2) Note that rear end of rocker shaft on intake side is open (no welch plug). Rear end of rocker shaft on exhaust side has welch plug installed. Ensure that welch plug in exhaust side rocker shaft is tight.

VALVE GUIDE SERVICING

1) Check valve guide for wear. If replacement is necessary, press out guide toward combustion chamber side of head. Measure guide bore in cylinder head. If bore exceeds .5512" (14.00 mm), ream head and install oversize guide. Shrink fit specification for oversize bore is .0006-.0017" (.015-.043 mm).

2) Heat cylinder head to 428-482°F (220-250°C). Press in new guide from top of head until tapered groove end protrudes .591" (15.01 mm) for standard guide, or .531" (13.5 mm) for modified guide. Ream guide to obtain specified clearance. See Replacement Valve Guides table for oversizes.

REPLACEMENT VALVE GUIDES

Application	Guide O.D. In. (mm)
Standard553 (14.05)
1st Oversize555 (14.10)
2nd Oversize559 (14.20)
3rd Oversize563 (14.30)
Standard Length	2.047 (52.00)
Modified Length	1.988 (50.50)

VALVE STEM OIL SEALS

Removal

Remove cylinder head from engine. Remove camshaft and rocker arm shaft assembly. Compress valve spring and remove keepers. Remove spring and retainer. Pull off oil seal.

Installation

1) Lubricate new oil seal with oil. Place protective sleeve (11 1 340) over valve stem and install seal. Press seal down until it fits tight against valve spring seat.

2) Install remaining valve components to complete installation. Note that end of valve spring that has tighter coil windings (color coded) is installed facing cylinder head.

VALVE SEAT INSERTS

1) When replacing valve seat, remove old seat by turning out with cutting tool. Drill out bore to appropriate oversize. Note valve seat oversize to be used and rebores head. Shrink fit specification for oversize bore is .004-.006" (.10-.15 mm).

2) When installing new seat, heat head to approximately 392°F (200°C) and chill valve seat to approximately -94°F (-70°C). Oversize replacement seats are available, as shown in Valve Seat Inserts table.

VALVE SEAT INSERTS

Application	Measurement In. (mm)
Intake	
1st Oversize	1.864 (47.35)
2nd Oversize	1.872 (47.55)
Exhaust	
1st Oversize	1.589 (40.35)
2nd Oversize	1.596 (40.55)

VALVE SPRINGS

To remove and install valve springs, use procedures explained in Valve Stem Oil Seals.

VALVE CLEARANCE ADJUSTMENT

1) Adjust valves in firing order (1-3-4-2), with piston of cylinder concerned on TDC at end of compression stroke. Use a feeler gauge to measure clearance between rocker arm eccentric and tip of valve.

2) Valve clearance should be .006-.008" (.15-.20 mm) with engine cold, or .008-.010" (.20-.25 mm) with engine at operating temperature.

3) To adjust valve clearance, loosen nut of rocker eccentric and insert a rod in eccentric hole. Rotate eccentric until proper clearance is obtained, then tighten lock nut. See Fig. 5.

Fig. 5: Adjusting Valve Clearance

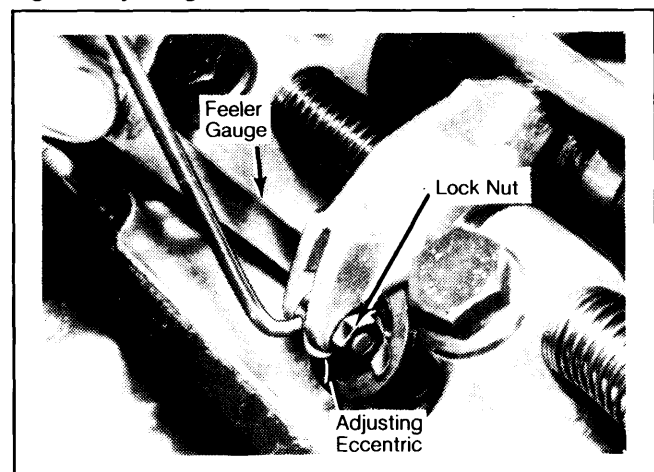

Never measure or adjust valve clearance between camshaft lobe and rocker arm.

PISTONS, PINS & RINGS

OIL PAN

Removal

Remove bolts securing steering to front axle carrier. Pull steering out of way. Drain oil. Remove oil pan bolts. Swing oil pan downward. Turn crankshaft and remove oil pan toward front of engine.

Installation

Clean gasket mating surfaces. Apply sealer to crankcase and oil pan sealing surfaces. Using new gasket, install oil pan in reverse order of removal procedure.

320i 4-CYLINDER (Cont.)

PISTON & ROD ASSEMBLY

Removal

1) Remove oil pan and cylinder head. Place piston to be removed at bottom of its stroke. If necessary, mark rod and rod cap for cylinder identification.

2) Remove rod cap and push piston and rod assembly out top of engine. Install cap on rod from which removed. If replacing pistons or rods, all pistons must be in same weight class, and all rods must be in same weight class.

Installation

Install rings on piston with marking "TOP" facing upward. Space ring end gaps 120° apart. Coat piston and cylinder walls with engine oil. Install piston and rod assembly with arrow facing toward front of engine. Install connecting rod cap.

FITTING PISTONS

1) Arrow on piston heads indicate direction of installation. Weight class is indicated by a "+" or "-" sign. All pistons must be in same weight class.

2) Measure piston diameter 90° to pin bore near bottom of piston skirt. For Mahle type pistons, measure about 5/8" from bottom of piston skirt. For KS type pistons, measure about 15/16" from bottom of piston skirt.

3) Measure cylinder bore diameter in line with crankshaft centerline and 90° to crankshaft centerline, at top, middle and bottom of cylinder. Difference between corresponding measurements is out-of-round and must not exceed .0004" (.01 mm).

4) Difference between top cylinder bore measurement and bottom cylinder bore measurement is taper, and should not exceed .0004" (.01 mm).

5) Difference between maximum cylinder diameter measurement and piston diameter measurement is piston-to-cylinder bore clearance.

6) If clearance is excessive, bore and hone cylinder block for installation of oversize pistons. See Piston Guide table for replacement piston sizes.

PISTON GUIDE

Application (Grade)	Diameter In. (mm)
Standard	3.503 (88.97)
Intermediate	3.506 (89.05)
No. 1 Oversize	3.513 (89.22)
No. 2 Oversize	3.522 (89.47)

FITTING RINGS

1) Place piston rings squarely into cylinder bore about 9/16" from bottom of bore. Use a feeler gauge to measure ring end gap.

2) With rings installed on piston, use a feeler gauge to measure ring side clearance. Take measurement around entire circumference of piston, between top of ring and ring land.

3) Install rings on piston with word "TOP" facing upward. Space ring end gaps 120° apart.

PISTON PIN REPLACEMENT

Removal & Installation

1) Remove circlip from pin bore groove. Push pin from piston and connecting rod. Piston pins and

pistons must be replaced as matched set. All pistons must be in same weight class, as must all connecting rods.

2) In event of excessive clearance, a new piston pin bushing may be pressed into rod. Drill and deburr oil holes, and install bushing so that seam is 90° from rod small end oil hole. Ream bushing so pin slides through under slight pressure.

3) Assemble connecting rod to piston with oil hole in rod's small end and arrow on piston head on same side. When installed, arrow on piston and rod's small end oil hole will face front of engine.

CRANKSHAFT MAIN & CONNECTING ROD BEARINGS

CRANKSHAFT MAIN BEARINGS

1) Use Plastigage method to measure main bearing clearances. Measure main bearing clearances 1 at a time. Wipe oil from surfaces to be checked. DO NOT allow crankshaft to turn once Plastigage is in place and bearing cap is tightened.

2) Remove bearing cap. Measure flattened width of Plastigage with scale furnished to determine clearance.

3) Standard crankshafts are marked with red or blue dots on side of counterweights. Factory ground crankshafts are identified by paint stripes marked on 1st counterweight. Bearings are also color coded.

4) Use crankshaft identification number for correct bearing replacement. If red and blue bearing shells are used in combination, be sure to install shells of same color on same side of crankshaft.

CONNECTING ROD BEARINGS

1) Use Plastigage method to measure connecting rod bearing clearances. Measure clearances 1 at a time. Mark connecting rod and cap for cylinder identification before removing caps.

2) Wipe oil from surfaces to be checked. DO NOT allow crankshaft to turn once Plastigage is in place and bearing cap is tightened.

3) Remove bearing cap. Measure flattened width of Plastigage with scale furnished to determine clearance. Whenever rod bearing caps are removed, cap bolts and nuts should be replaced.

CRANKSHAFT END THRUST

Attach a dial indicator to crankcase with indicator point contacting flywheel. Push flywheel forward and zero dial indicator. Pull flywheel rearward and record crankshaft end thrust. If end thrust is excessive, replace thrust bearing (center main bearing shells).

REAR MAIN BEARING OIL SEAL

Removal

1) Remove transmission and flywheel. Remove 2 rear oil pan bolts and loosen remaining oil pan bolts. Carefully separate oil pan gasket from seal retainer, using a sharp tool.

2) Remove rear main bearing oil seal retainer from rear of crankcase. Remove oil seal from seal retainer.

BMW Engines

320i 4-CYLINDER (Cont.)

Installation

Coat oil pan gasket at seal retainer contact surface with sealing compound. Install oil seal into retainer. Coat seal lips with oil and install retainer and seal. Install remaining components.

ENGINE OILING

CRANKCASE CAPACITY

Capacity is 4 quarts (3.8L) without filter replacement; 4.25 quarts (4.0L) with filter replacement.

NORMAL OIL PRESSURE

Oil pressure should be 11-17 psi (0.8-1.2 kg/cm²) at idle. At 4000 RPM, oil pressure should be about 57 psi (4.0 kg/cm²).

OIL PRESSURE RELIEF VALVE

Oil pressure relief valve opens at 59-64 psi (4.1-4.5 kg/cm²).

ENGINE OILING SYSTEM

A rotor type oil pump pressure feeds oil to a full-flow oil filter. From oil filter, oil is circulated through drilled passages to all moving parts of the engine. Oil pump is chain driven off of crankshaft.

OIL PUMP

Removal

Remove oil pan. Remove oil pump sprocket and drive chain. Remove two bolts mounting pump to crankcase and remove oil pump.

Disassembly

1) Unscrew union and remove relief valve spring and plunger from pump body. Remove pick-up tube and cover from pump body. Clean all parts and blow dry with compressed air.

2) If inner rotor replacement is required, remove pump sprocket hub from rotor shaft using a puller. Install new rotor in pump body and press hub onto rotor shaft to a distance of 1.677-1.685" (42.5-42.8 mm) between hub and rotor faces. See Fig. 6.

Inspection

1) Using a feeler gauge, measure clearance between outer rotor and pump body. If measurement exceeds specification, replace pump body.

2) Using a feeler gauge, measure clearance between inner and outer rotor. If measurement exceeds specification, replace rotors.

3) Lay a straightedge over pump body. Insert a feeler gauge between straightedge and rotors and measure clearance over rotors. If clearance exceeds specification, replace pump body.

OIL PUMP SPECIFICATIONS

Application	Measurement In. (mm)
Rotor-to-Pump Body006-.011 (.15-.27)
Clearance Between Rotors0047-.0079 (.119-.200)
Clearance Over Rotors0014-.0037 (.035-.095)
Relief Valve Spring	
Free Length	2.677 (67.99)
Installed Length	2.618 (66.50)

Fig. 6: Measuring Distance Between Sprocket Hub and Rotor Face

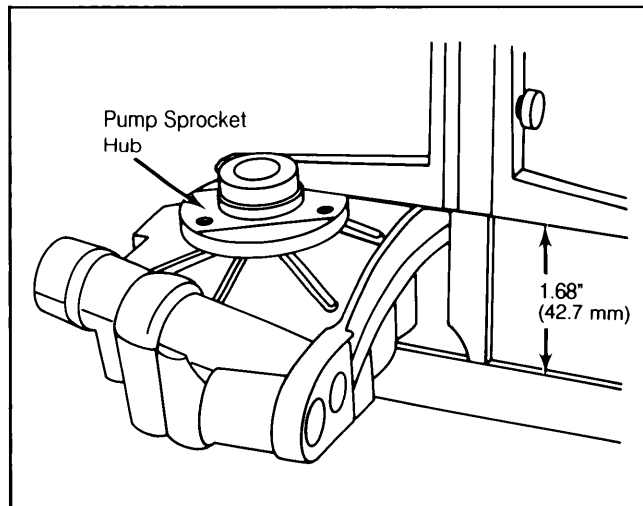

Do not use arbor press to remove sprocket hub. Use a puller to remove hub.

Reassembly

Reassemble oil pump in reverse order of disassembly, using new parts where required.

Installation

1) Prime oil pump. To install, reverse removal procedure. Check oil pump drive chain tension. Chain tension is correct if chain gives when slight thumb pressure is exerted midway between oil pump and crankshaft sprockets.

2) Two drive chains are available for tension adjustment. If correct tension cannot be obtained with either chain, shims are available for installation between oil pump and cylinder block. Ensure oil hole in shim aligns with oil hole in pump and block.

ENGINE COOLING

THERMOSTAT

Thermostat begins opening at 176°F (80°C), and is fully open at 203°F (95°C).

COOLANT CAPACITY

Capacity is 7.4 quarts (7.0L).

RADIATOR CAP

Radiator cap pressure relief valve opens at 14 psi (1.0 kg/cm²)

WATER PUMP

Removal & Installation

Loosen alternator bracket. Remove fan, pulley and drive belt. Remove coolant hoses from water pump. Remove water pump. Using new gasket, install water pump and remaining components in reverse order of removal.

BMW Engines

6-43

320i 4-CYLINDER (Cont.)

ENGINE SPECIFICATIONS

GENERAL SPECIFICATIONS

Year	Displacement		Fuel System	HP@RPM	Torque Ft. Lbs.@RPM	Compr. Ratio	Bore		Stroke	
	Cu. In.	cc					In.	mm	In.	mm
1982	107.8	1766	Fuel Inj.	101@5800	100@4500	8.8:1	3.50	89.0	2.79	71.0

VALVES

Engine Size & Valve	Head Diam. In. (mm)	Face Angle	Seat Angle	Seat Width In. (mm)	Stem Diameter In. (mm)	Stem Clearance In. (mm)	Valve Lift In. (mm)
1766 cc Intake	1.805 (45.85)	45.5°	45°	.059-.083 (1.50-2.10)	.3134-.3139 (7.960-7.975)	.0010-.0020 (.025-.055)
Exhaust	1.490 (37.85)	45.5°	45°	.061-.081 (1.55-2.05)	.3129-.3134 (7.945-7.960)	.0015-.0030 (.040-.070)

PISTONS, PINS, RINGS

Engine	PISTONS	PINS		RINGS		
	Clearance In. (mm)	Piston Fit In. (mm)	Rod Fit In. (mm)	Ring No.	End Gap In. (mm)	Side Clearance In. (mm)
1766 cc Alcan/Nural & Mahle Pistons	.0018 (.045)	.00004-.00020 ¹ (.0010-.0050)	Push Fit	No. 1 No. 2 No. 3	.012-.020 (.30-.50) .008-.016 (.20-.40) .010-.016 (.25-.40)	.0024-.0036 ² (.061-.092) .0012-.0024 ³ (.030-.061) .0008-.0020 ⁴ (.020-.052)

- ¹ — .00008-.00024" (.0020-.0061 mm) for KS Pistons.
² — Side clearance measurement is same for KS Pistons.
³ — .0016-.0028" (.040-.072 mm) for KS Pistons.
⁴ — .0012-.0024" (.030-.061 mm) for KS Pistons.

CRANKSHAFT MAIN & CONNECTING ROD BEARINGS

Engine	MAIN BEARINGS				CONNECTING ROD BEARINGS		
	Journal Diam. In. (mm)	Clearance In. (mm)	Thrust Bearing	Crankshaft End Play In. (mm)	Journal Diam. In. (mm)	Clearance In. (mm)	Side Play In. (mm)
1766 cc	2.165 (55.0)	.0012-.0026 (.030-.070)	Center	.0033-.0068 (.085-.174)	1.8898 (48.0)	.0009-.0031 (.023-.078)

BMW Engines

320i 4-CYLINDER (Cont.)

ENGINE SPECIFICATIONS (Cont.)

VALVE SPRINGS

Engine	Free Length In. (mm)	PRESSURE Lbs. @ In. (Kg @ mm)	
		Valve Closed	Valve Open
1766 cc	1.71 ¹ (43.5)	64@1.48 (29@37.6)	154@1.12 (70@28.5)

¹ — Depending on spring manufacturer, some springs may be 1.811" (46.0 mm).

CAMSHAFT

Engine	Journal Diam. In. (mm)	Clearance In. (mm)	Lobe Lift In. (mm)
1766 cc ¹			
No. 1	1.3769-1.3795 (34.975-35.041)	.0013-.0029 (.034-.074)	.274-.280 (6.95-7.11)
No. 2	1.6525-1.6551 (41.975-42.041)		
No. 3	1.6919-1.6945 (42.975-43.041)		

¹ — End play is .0008-.0051" (.020-.130 mm).

TIGHTENING SPECIFICATIONS

Application	Ft. Lbs. (N.m)
Camshaft Oiler (Hollow Bolt)	8-9 (11-13)
Connecting Rod Bolts	38-41 (51-56)
Crankshaft Damper/Pulley	101-108 (140-150)
Cylinder Head (Cold) ¹	
Step 1	25-32 (33-44)
Step 2	49-52 (67-71)
Step 3	56-59 (77-81)
Step 4	Repeat Step 3
Exhaust Manifold	22-24 (29-32)
Flywheel Bolts (Use Loctite)	72-83 (98-113)
Main Bearing Caps	42-45 (57-62)

¹ — Recheck torque at 1000 mile service and retighten if necessary.