

TOYOTA SEPARATE CARRIER

Celica (Limited Slip)
Corolla
Corona (Limited Slip)
Cressida

Land Cruiser
Pickup
Supra (Limited Slip)

DESCRIPTION

The axle assembly is hypoid gear type with a separate carrier housing. It comes in slightly different models for use in all Toyota vehicles. Two-pinion differential cases are one-piece design while four-pinion cases are two-piece design. The differential side bearing preload is set with adjusting nuts on all models. The pinion bearing preload can be set with a solid spacer and adjusting shim or with a collapsible spacer.

AXLE RATIO & IDENTIFICATION

Toyota uses only one basic type of axle assembly. Any differences in Removal & Installation or Overhaul procedures will be noted where they occur. To determine axle ratio, divide number of ring gear teeth by number of pinion gear teeth.

REMOVAL & INSTALLATION

FRONT AXLE SHAFTS & BEARINGS (LAND CRUISER & 4-WD PICKUP)

NOTE — On vehicles equipped with locking hubs, refer to Locking Hubs article in this Section to remove hub, then proceed with removal procedures. Ensure locking knob is set to "FREE" position before removal.

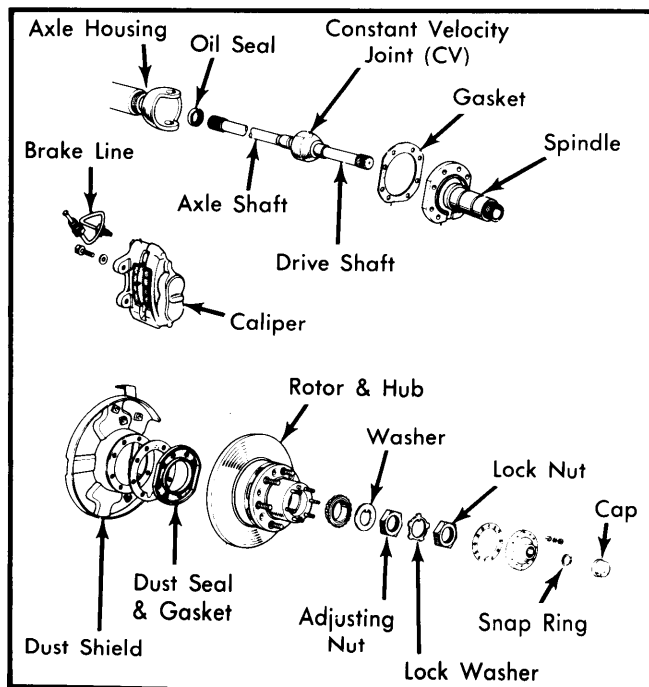

Fig. 1 Exploded View of Front Axle Shaft Assembly (4-WD Pickup and Land Cruiser)

Removal — 1) Raise and support vehicle. Remove wheel and tire assembly. Disconnect and remove brake line at brake caliper and remove caliper assembly. Remove dust cover and snap ring. Remove axle flange lock washers with punch. Install bolts in flange bolt holes and turn bolts equally to remove flange.

NOTE — Tab of lock washer must be straightened with chisel to facilitate removal of outer lock nut.

2) Remove outer lock nut with suitable wrench (SST 09607-60020). Then remove lock washer and adjusting nut. Place hand over axle shaft and carefully move axle hub/disc assembly back and forth to remove outer bearing and washer. Remove axle hub/disc assembly.

3) To remove inner wheel bearing, pry out oil seal and remove bearing. Replace outer bearing races by drifting out, then replace using bearing installer (SST 09608-35013).

4) Remove 8 dust shield retaining bolts, then remove dust seal, gasket and shield. Remove spindle assembly, tapping with a drift if necessary, then remove gasket. Align one flat of constant velocity (CV) joint so it is pointing upward, then extract axle/drive shaft assembly. Remove grease and clean assembly with suitable solvent.

CAUTION — Do NOT attempt to remove steering knuckle. Any adjustment to specifications requires alignment of axle shaft and adjustment of knuckle bearing preload.

Installation — To install, reverse removal procedure using the following notes: Install axle/drive shaft with one flat of constant velocity joint pointing upward. Pack steering knuckle cavity with molybdenum disulphide (lithium base grease) to about $\frac{3}{4}$ of knuckle volume. Tighten all bolts.

REAR AXLE SHAFTS

NOTE — Land Cruiser models with semi-floating rear axles require removal of axle housing inspection cover BEFORE attempting removal of axle shaft.

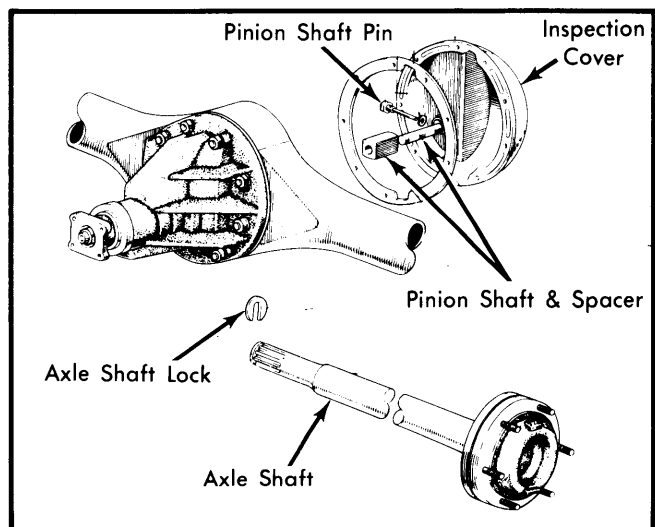

Fig. 2 Exploded View of Land Cruiser Rear Axle Shaft Assembly (Semi-Floating Axle Shafts Shown)

Drive Axles

TOYOTA SEPARATE CARRIER (Cont.)

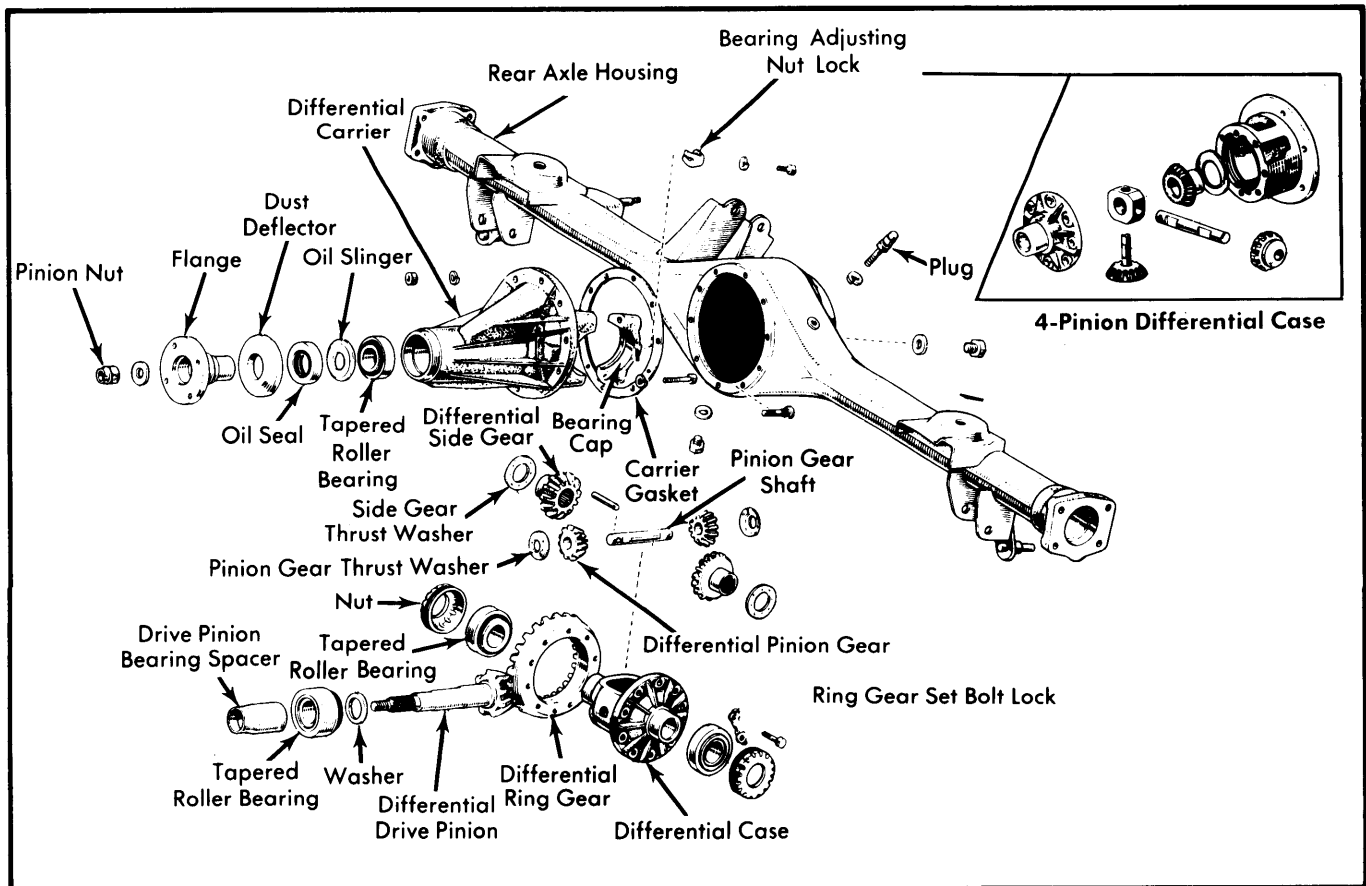

Fig. 3 Exploded View of Typical Toyota Two Pinion Rear Differential Assembly (Four Pinion Differential Case Shown in Inset)

Removal (Land Cruiser – Semi-Floating) – Raise and suitably support vehicle and remove tire, wheel and brake drum. Drain axle housing and remove inspection cover. Remove pinion shaft lock pin, then remove pinion shaft and spacer. Remove axle lock circlip, then remove axle shaft.

Installation – To install, reverse removal procedure and fill differential with appropriate lubricant.

Removal (Land Cruiser – Full Floating) – Remove axle flange bolts, then using punch, remove lock washer cones. Remove axle shaft and discard gasket.

Installation – To install, replace gasket and reverse removal procedure.

Removal (Pickup) – 1) Raise and support vehicle, remove tire and wheel, then drain differential housing. Remove parking brake cable guide clip and clamp bolt at crossmember and frame, then disconnect parking brake cable from intermediate lever. Disconnect and cap brake line at wheel cylinder. Remove brake drum mounting bolts and drum.

2) Working on rear of backing plate, remove 4 backing plate-to-axle housing nuts. Remove axle shaft and backing plate as an assembly. Using suitable snap ring pliers, remove axle shaft snap ring. Remove and discard "O" ring. Install axle shaft remover (SST 09521-25011) and press out axle shaft, ensuring not to damage oil seal in housing. Remove bearing retainer.

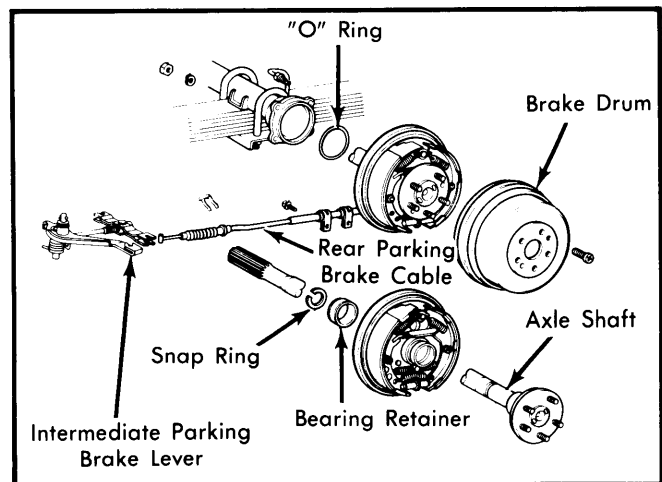

Fig. 4 Exploded View of Pickup Rear Axle

Installation – To install, reverse removal procedure, install new "O" ring and fill differential with appropriate lubricant. Ensure bearing retainer is installed with small tapered end toward bearing.

Removal (All Others) – Raise and support vehicle, remove tire, wheel and brake drum. Working through hole in axle flange, remove bearing retainer-to-axle housing bolts. Using a slide hammer, remove shaft from housing using care not to

TOYOTA SEPARATE CARRIER (Cont.)

damage axle seal. If axle housing seal is being replaced, coat sealing lip with grease before installing.

Installation — To install, reverse removal procedure.

REAR AXLE BEARINGS

Removal (Land Cruiser) — With axle shaft removed, raise and support vehicle. Remove brake drum retaining screw, then remove brake drum. Using bearing wrench (SST 09607-60020), remove lock nut. Remove retaining screw from bearing adjusting nut and remove adjusting nut and lock washer. Remove outer bearing, then remove hub assembly. Replace inner bearing after removing oil seal.

Installation — To install, coat inner walls of hub with grease and reverse removal procedure. Install adjusting nut to torque of 43 ft. lbs. (58 N.m), rotate hub back and forth 3 or 4 times and retighten adjusting nut to specification. Back off adjusting nut $\frac{1}{8}$ to turn. Install lock screw. Tighten lock nut to 58-72 ft. lbs. (79-98 N.m).

Removal (Pickup) — Disassemble brake assembly and remove oil seal with suitable slide hammer. Press out bearing. Index bearing case and remove by installing nuts to the bolts, knocking bolts out with hammer, then removing bearing case. Remove axle shaft oil seal from housing with suitable slide hammer.

Installation — Install axle shaft oil seal with installer (SST 09608-30011). Align bearing case index marks, position long bolts at top and short bolts at bottom and press into case and backing plate. Install bearing and oil seal. Reassemble brake assembly.

Removal (All Others) — To remove bearing, grind part way through bearing retainer ring using caution not to nick axle shaft. Cut remaining portion of retaining ring using a cold chisel. Remove split retaining ring and press bearing off shaft. Remove spacer from shaft.

Installation — 1) To install, place spacer and bearing onto shaft and press into place. Heat new retaining ring to about 300°F (150°C) and press into place.

NOTE — The retaining ring will show a faint yellow color when heated to proper temperature.

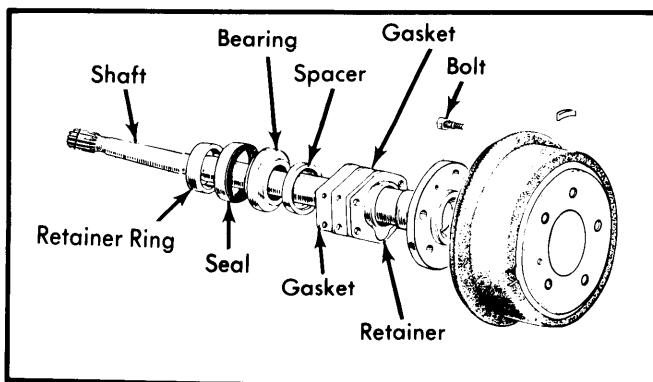

Fig. 5 Exploded View of Typical Rear Axle Assembly for All Models Except Land Cruiser & Pickup

2) On Corolla models only, measure thickness of brake backing plate and choose proper thickness selective fit gasket. Install gasket between backing plate and axle housing flange. On all other models, place gasket(s) into position so when shaft is installed, gasket(s) will be between bearing retainer and backing plate.

3) Ensure notched portion of retainer and gaskets (if equipped) are installed in the position shown in illustration. Install axle shaft, check alignment of gaskets, then tighten bolts.

PINION SEAL REPLACEMENT (ON VEHICLE)

Removal (Except Land Cruiser) — 1) Index mark propeller shaft and companion flange and set parking brake. Disconnect and remove propeller shaft.

2) On Corona and Pickup models, measure and record total pinion preload with pull scale attached to pinion flange at one of the propeller shaft bolt holes. Measurement is made within the small movement caused by the ring gear and axle shaft backlash. Axle shafts are locked by parking brake.

3) On all models, loosen stacked portion of pinion shaft nut. Install suitable holding tool to flange and remove the nut. Using flange puller, remove pinion flange. Remove oil seal using suitable puller and remove oil slinger. Remove bearing with bearing puller, then remove spacer and shim (Pickup 8" differential).

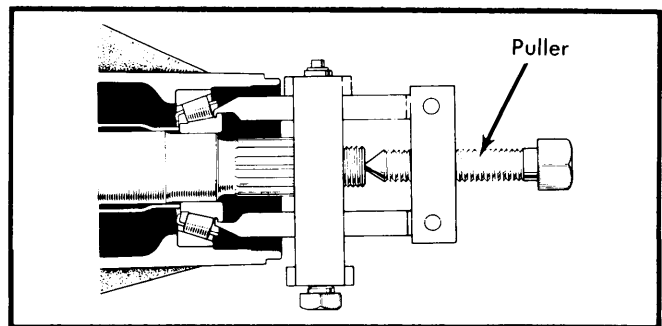

Fig. 6 Removing Drive Pinion Gear Front Bearing

NOTE — Toyota recommends installing new spacer for Celica, Corona and Supra models whenever oil seal is replaced.

Installation (Corona, Cressida & Pickup) — 1) Install spacer, shim (Pickup 8" differential), bearing and oil slinger. Apply grease to seal lip and install to pinion flange. Install pinion flange. Remove tool and install new nut. Tighten nut to 69 ft. lbs. (94 N.m) on Corolla 6" differential and to 80 ft. lbs. (109 N.m) on all other models while holding companion flange stationary.

2) Rotate pinion in both directions to seat bearing, then measure bearing preload (starting torque). If preload is excessive, replace spacer and repeat procedure. If preload is insufficient, gradually tighten nut in increments of 5-10°, until preload is obtained. If preload is exceeded, replace spacer.

TOYOTA SEPARATE CARRIER (Cont.)

Complete installation by reversing removal procedure. Add suitable lubricant if required.

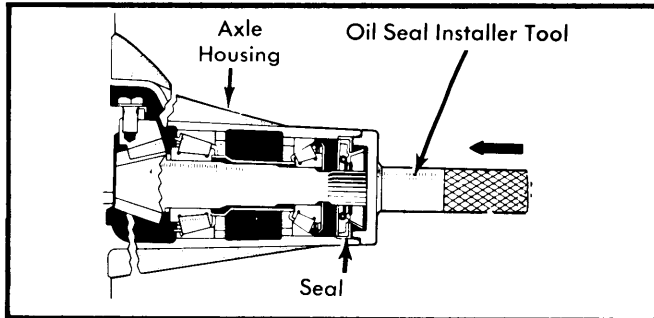

Fig. 7 Installing Oil Seal

Installation (All Others) — 1 Install spacer, bearing and oil slinger. Apply grease to seal lip and install to depth shown in "Pinion Seal Depth" chart. Using tool and attached to pinion flange, install pinion flange. Remove tool and install new nut. Tighten nut to 80 ft. lbs. (109 N.m) while holding companion flange stationary.

2 Rotate pinion in both directions to seat bearing, then measure bearing preload (measured within range of backlash between drive pinion and ring gear with parking brake set). If preload is excessive, replace spacer and repeat procedure. If preload is insufficient, gradually tighten nut in increments of 5-10° until preload is obtained. If preload is exceeded, replace spacer. Complete installation by reversing removal procedure. Add suitable lubricant if required.

Pinion Seal Depth Chart

Application	Depth
Celica & Supra16" (4 mm)
Corolla	
6.00" Ring Gear04" (1 mm)
6.38" Ring Gear	To Carrier End Face
6.70" Ring Gear16" (4 mm)
Corona	
6.70" Ring Gear16" (4 mm)
7.10" Ring Gear04" (1 mm)
All Others04" (1 mm)

DIFFERENTIAL CARRIER

Removal — Drain oil from axle housing. Loosen hub nuts and remove wheels. Index propeller shaft to companion flange and remove propeller shaft. Remove axle shafts as previously described. Loosen bolts and remove differential carrier.

NOTE — Do not damage oil seal during removal of axle shafts if it is not scheduled for replacement.

Installation — To install, reverse removal procedure, noting the following: Coat both sides of carrier-to-housing gasket with sealer before installation. Fill axle housing with gear oil.

OVERHAUL

FRONT AXLE SHAFT & SPINDLE
(LAND CRUISER & 4-WD PICKUP)

Disassembly — 1) Mount spindle in vise and remove bushing with suitable puller. Install new bushing with installing tool and

press. Inspect axle shaft for wear or damage and carefully inspect constant velocity (CV) joint for excessive looseness.

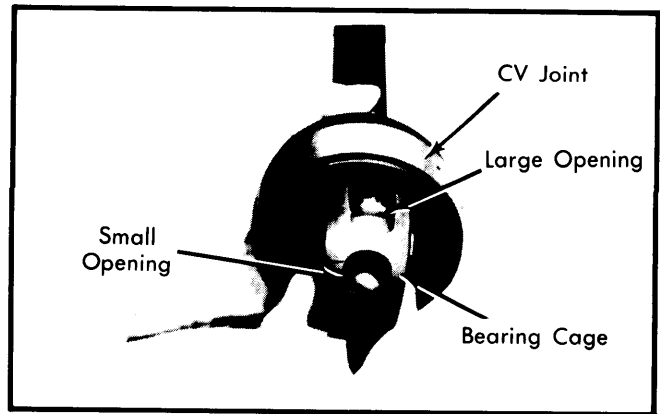

Fig. 8 Removing & Installing CV Joint Bearing Cage & Retainer

2 Mount axle shaft (inner shaft) in a vise with CV joint pointing upward. Place a brass drift against inner race and drive off drive shaft (outer shaft). Do not allow drive shaft to drop. Remove snap rings from axle shaft.

3 Tilt bearing cage and inner race outward from housing and remove 6 ball bearings. Remove each ball separately and do not drop. Turn bearing cage and retainer outward from drive shaft and align the 2 larger openings of the bearing cage with 2 protrusions of CV joint. Remove bearing retainer and cage, separate by turning retainer perpendicular to large bearing openings and pulling out.

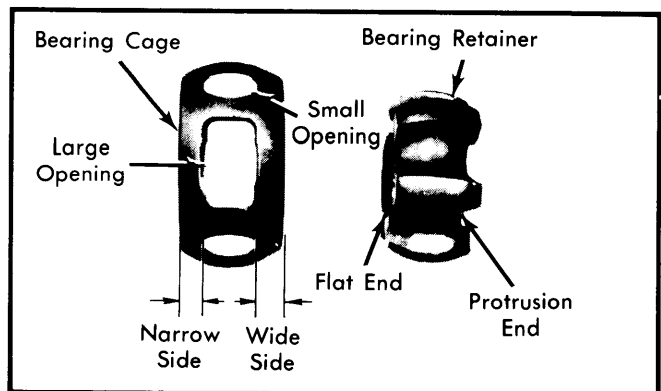

Fig. 9 Exploded View of Constant Velocity (CV) Joint Bearing Cage & Retainer

Reassembly — Coat bearing retainer, cage and balls with suitable grease and reverse disassembly procedure. Ensure protrusion end of bearing retainer is covered by the wide portion of bearing cage during reassembly. When installing bearing retainer and cage into outer shaft, wide side of bearing cage must be on outside portion. After reassembly, pack drive shaft end with lithium base grease. Install new snap rings on axle shaft, insert axle shaft to drive shaft keeping inner snap ring compressed.

NOTE — After reassembly, ensure that axle shaft can NOT be pulled out of drive shaft CV joint.

TOYOTA SEPARATE CARRIER (Cont.)

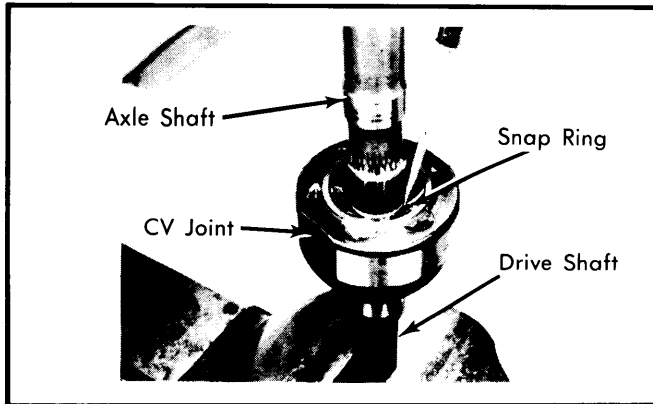

Fig. 10 Installing Axle Shaft to CV Joint

DIFFERENTIAL

NOTE — Front differentials are overhauled using same procedures as those described for rear differentials.

Disassembly — 1) Mount carrier in holding fixture and perform the following pre-disassembly checks: Tooth contact pattern, ring gear backface runout, ring gear backlash and total preload. Total bearing preload is measured amount of pinion bearing preload recorded prior to disassembly PLUS 2.6-4.3 INCH lbs. (.29-.49 N.m) for Celica, Corolla, Corona and Supra models and PLUS 3.5-5.2 INCH lbs. (.40-.59 N.m) for all other models.

NOTE — Note quantity and position of any shims.

2) Loosen stacked portion of pinion shaft nut, install holder and remove nut. Using flange puller, remove companion flange. Remove oil seal, bearing and slinger. Punch identification marks on left and right bearing caps to prevent intermixing. Remove adjusting nut lock bolt(s). Remove side bearing bolts, caps and adjusting nuts.

NOTE — Maintain all left and right side bearing components identified for installation on correct side.

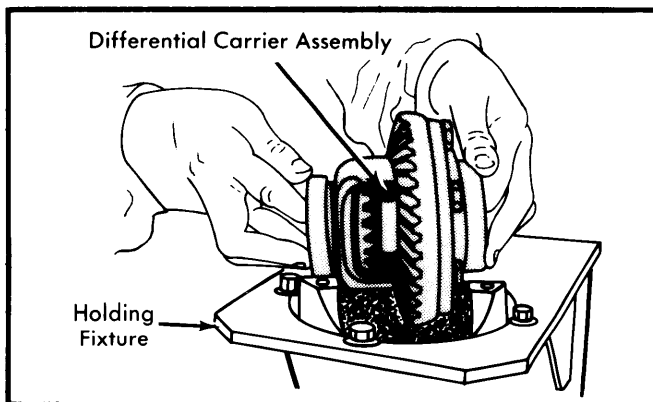

Fig. 11 Removing Differential Case

3) Remove differential case assembly with side bearings. Remove drive pinion, mount pinion in suitable holder and with suitable puller, remove rear pinion bearing. Use caution to avoid deforming shim that adjusts pinion depth. Press out front and rear pinion bearing outer races.

NOTE — Differential case has cutaways to ease side bearing removal.

4) Remove side bearings from differential case. Index ring gear to case and straighten ring gear bolt lock plates, then remove bolts. Mount case assembly in vise so ring gear teeth are pointed down. Tap ring gear from case using a soft faced hammer. On two-pinion differentials, remove pinion gear shaft retaining pin and drive out gear shaft. Then remove pinion gears, side gears and thrust washers.

5) On four-pinion differentials, index differential case cover to case. Remove cover attaching bolts, then drive out 3 pinion shafts. Remove pinion gears, pinion shaft holder, side gears and thrust washer(s).

NOTE — The 3 longer differential cover bolts are used to secure pinion shafts in four-pinion differentials.

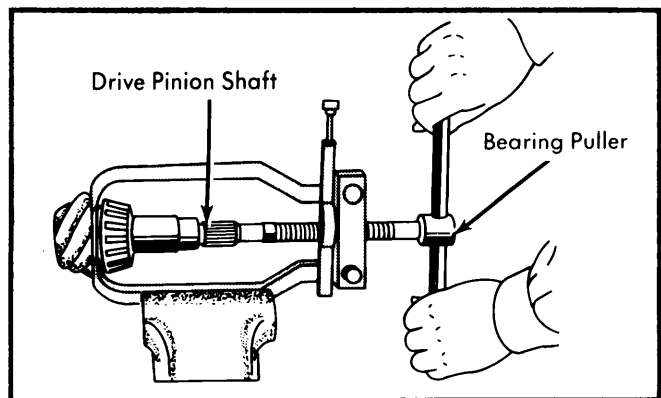

Fig. 12 Removing Drive Pinion Gear Rear Bearing

Case Reassembly — 1) Lubricate all components with hypoid gear lubricant. On 2-pinion models, assemble side gears and pinion gears into differential case. Make sure oil groove, if present, on side gear thrust washer faces toward gear. On 4-pinion types, install side gears, thrust washers, differential pinions, pinion shaft holder, differential shaft and pinion shaft. Install differential case cover, aligning index marks and tighten bolts. Note location of 3 longer bolts (pinion shaft bolts).

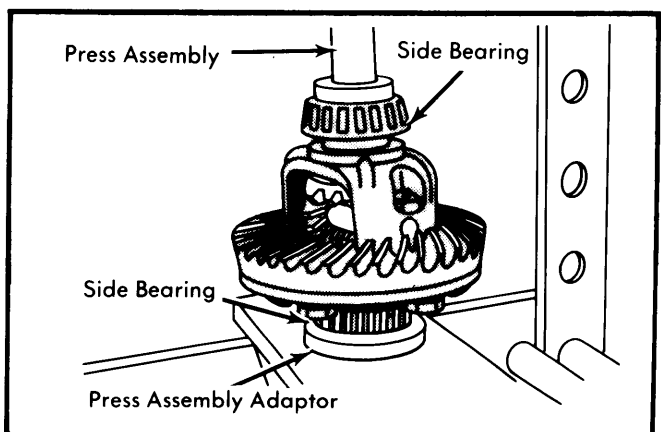

Fig. 13 Installing Side Bearing On Differential Case

Drive Axles

TOYOTA SEPARATE CARRIER (Cont.)

2) Check backlash between side gears and pinion gears. If not within specifications, install suitable selective fit thrust washers. Install equal thickness thrust washers on each side, if possible.

3) Press differential side bearings onto differential case. Heat ring gear in oil or water bath to approximately 212°F (100 °C), then quickly wipe off gear and install on differential case. Fit bolts and tighten evenly, then bend over lock tabs. Install differential case assembly on differential carrier and measure ring gear runout.

4) If runout is within specifications, remove differential carrier and bend up on ring gear lock plate. If runout exceeds specifications, remount ring gear 180° from original position on differential case. If this fails to bring ring gear into specifications, remove ring gear from case and examine runout. If case runout is within range specified for ring gear, then ring gear is at fault and should be replaced. Remove ring gear and case assembly from carrier.

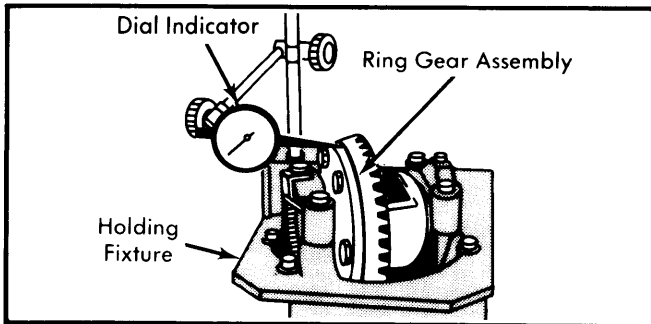

Fig. 14 Measuring Ring Gear Backface Runout

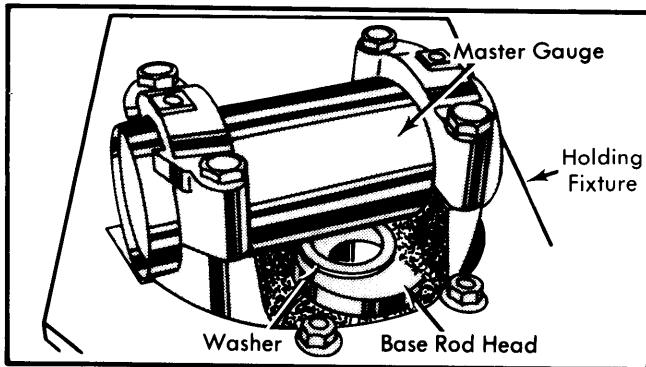

Fig. 15 Toyota Master Gauge for Measuring Drive Pinion Installed Height

Drive Pinion Depth — 1) Install drive pinion cups into the carrier. Adjust pinion depth using Toyota Master Gauge. Insert drive pinion rear bearing onto base rod. Install base rod head. Insert this assembly into carrier from the rear. Install front pinion bearing into carrier from front end. Install collar, preload flange pulley and nut onto front end of base rod. Using a spring scale and a thin cord, measure preload of drive pinion bearings. Tighten nut until preload is within specifications.

2) Install master gauge into differential side bearing bores. Install bearing caps and tighten. Select a shim that will just fit between master gauge and base rod head. One shim or none must be used; do not use more than one. After selecting the shim, remove all components of master gauge kit from carrier.

Install shim onto drive pinion. If it has a chamfered edge, install that edge toward pinion. Press rear bearing into place.

Pinion Bearing Preload — 1) Install bearing spacer onto pinion shaft and insert assembly into carrier from rear. Insert shims (if any) that were removed during disassembly onto pinion shaft.

2) Install front bearing, oil deflector, flange, washer and nut. Torque pinion flange nut to specifications. Install preload flange onto pinion flange.

3) Using a torque wrench, measure pinion bearing preload. If not to specifications, shims in front of preload spacer must be changed. If preload is too great, increase shim thickness; if preload is too small, decrease shim thickness.

4) Use either two shims or none for adjustment. If thicker shim pack is needed, use thicker shims, not more shims. When preload is correct, remove flange, install oil seal and reassemble.

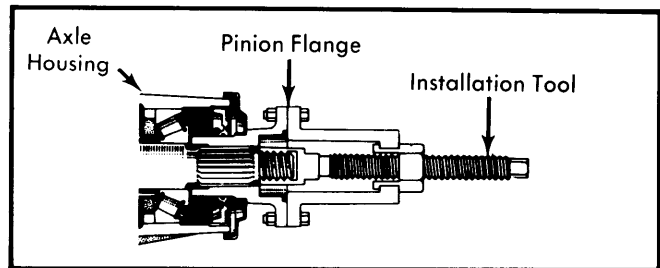

Fig. 16 Installing Pinion Flange

Backlash & Side Bearing Play — 1) Assemble bearings in cups and install onto carrier. Install differential assembly into carrier, then fit adjusting nuts. Put bearing caps on in original position. Tighten bolts carefully, while checking that adjusting nuts are aligned in bearing bore threads. Install dial gauge so plunger touches flange side of ring gear. Tighten flange side adjusting nut until a slight backlash remains. During operation, rotate ring gear through several revolutions to seat side bearings. Tighten tooth side nut just to the point where there is no differential end play when measured with dial indicator. At this point tighten tooth side nut an additional 1-1½ notches to preload side bearings.

Combined (Side & Pinion) Bearing Preload

Application	New Bearing INCH Lbs. (N.m)
Corolla	
6.00" Ring Gear	7.4-14.3 (.84-1.62)
6.38" Ring Gear	10.4-17.4 (1.17-1.97)
6.70" Ring Gear	11.3-18.2 (1.28-2.06)
Celica & Supra	11.3-18.2 (1.28-2.06)
Corona	
6.70" Ring Gear	11.3-18.2 (1.28-2.06)
7.10" Ring Gear	17.4-18.2 (1.97-2.06)
Cressida	17.4-24.2 (1.97-2.73)
Pickup	20.0-27.8 (2.26-3.14)
Land Cruiser	20.0-27.8 (2.26-3.14)

TOYOTA SEPARATE CARRIER (Cont.)

2) Confirm that some backlash is still present. Install the preload flange onto the pinion shaft flange and measure preload. If within specifications go on to next step; if not, tighten tooth side adjusting nut one more notch and recheck.

3) Install dial gauge so that plunger is perpendicular to ring gear tooth. Measure ring gear backlash. If not within specifications, turn left and right adjusting nuts to shift differential assembly in proper direction. If left side is loosened one notch, the right side must be tightened one notch to maintain side bearing preload. Continue procedure until backlash is within specifications. One notch will change backlash .002" (.05 mm). Tighten side bearing cap bolts. Check gear tooth contact pattern. See *Gear Tooth Contact Pattern* at beginning of this section. Install differential carrier.

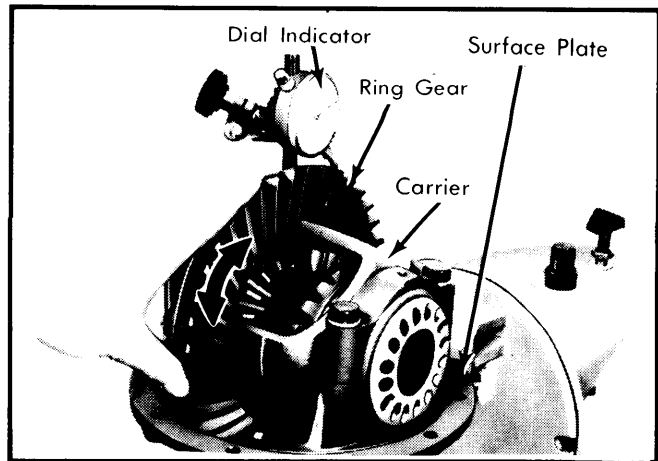

Fig. 17 Measuring Ring Gear Backlash

AXLE ASSEMBLY SPECIFICATIONS

Application	New Bearing INCH Lbs. (N.m)
Drive Pinion Bearing Preload	
Celica & Supra	8.7-13.9 (.98-1.57)
Corolla	
6.00" Ring Gear	5.7-10.8 (.64-1.22)
6.38" Ring Gear	8.7-13.9 (.98-1.57)
6.70" Ring Gear	8.7 13.9 (.98-1.57)
Corona	
6.70" Ring Gear	8.7-13.9 (.98-1.57)
7.10" Ring Gear	14.0-19.0 (1.58-2.15)
Cressida	13.8-19.0 (1.56-2.15)
Pickup	16.5-22.6 (1.86-2.55)
Land Cruiser	16.5-22.6 (1.86-2.55)
	Specification In. (mm)
Side-to-Pinion Gear Backlash	
Corolla	
6.00" Ring Gear0008-.006 (.02-.15)
6.38" Ring Gear0008-.008 (.02-.20)
6.70" Ring Gear002-.008 (.05-.20)
Land Cruiser0008-.008 (.05-.20)
All Others002-.008 (.05-.20)
Drive Pinion-to-Ring Gear Backlash	
Corolla	
6.00" Ring Gear004-.006 (.10-.15)
6.38" & 6.70" Ring Gear005-.007 (.13-.18)
Land Cruiser006-.008 (.15-.20)
All Others005-.007 (.13-.18)
Ring Gear Backface Runout	
Pickup & Land Cruiser	① .004 (.10)
All Others	① .003 (.07)

①— Maximum Clearance.

TIGHTENING SPECIFICATIONS

Application	Ft. Lbs. (N.m)
Drive Pinion Flange Nut	
Corolla	
6.00" Ring Gear	69-145 (94-197)
6.38" & 6.70" Ring Gear	80-174 (109-236)
Celica, Corona, Cressida and Supra	80-174 (109-236)
Pickup	
7.50" Ring Gear	80-174 (109-236)
8.00" Ring Gear	123-152 (167-207)
Land Cruiser	145-174 (197-236)
Differential Bearing Cap Bolts	
Corolla	
6.00" Ring Gear	40-47 (54-64)
6.38" Ring Gear	36-51 (49-69)
6.70" Ring Gear	51-65 (69-88)
Celica, Corona, Cressida, Supra and Pickup	51-65 (69-88)
Land Cruiser	65-80 (88-109)
Ring Gear-to-Case Bolts	
Corolla	
6.00" Ring Gear	65-76 (88-103)
6.38" Ring Gear	51-58 (69-79)
6.70" Ring Gear	65-76 (88-103)
Celica, Corona, Cressida, Supra and Pickup	65-76 (88-103)
Land Cruiser	76-87 (103-118)
Carrier-to-Axle Housing	
Corona	18-25 (24-34)
Pickup	14-22 (19-30)
Backing Plate & Axle Retainer Flange Bolts	
Celica and Supra	18-25 (24-34)
Corolla, Corona and Cressida	43-54 (58-73)
Pickup	43-58 (58-79)
Land Cruiser	29-40 (39-54)
Front Hub-to-Flange	① 20-25 (27-34)
Adjusting Nut	① 58-72 (69-98)
Wheel Nuts	① 65-87 (88-118)

①— Pickup 4-WD & Land Cruiser.