

FIAT BRAVA & SPIDER 2000

DESCRIPTION

Rear axle assembly uses an integral carrier type differential having a hypoid type ring and drive pinion gear set. Drive pinion bearing preload is maintained by a collapsible spacer and differential bearing preload is obtained through the use of shims between the bearings and rear axle housing. Semi-floating axles use ball bearings retained on the axle by a press fit retaining ring and the axle is secured in the housing with a retaining flange. A removable rear cover permits inspection and service of differential assembly.

AXLE RATIO & IDENTIFICATION

Fiat uses 2 axle ratios, the Spider manual uses a 3.90:1 gear ratio, 10 tooth pinion and 39 tooth ring gear. All other models use a 3.58:1 gear ratio, 12 tooth pinion and 43 tooth ring gear.

REMOVAL & INSTALLATION

AXLE SHAFTS & BEARINGS

Removal — 1) Raise and support vehicle. Remove rear wheels. On Brava, remove brake drums. On Spider 2000, remove brake calipers and disc. Working through a large hole in axle shaft flange, remove bolts and lock washers holding retaining plate to axle.

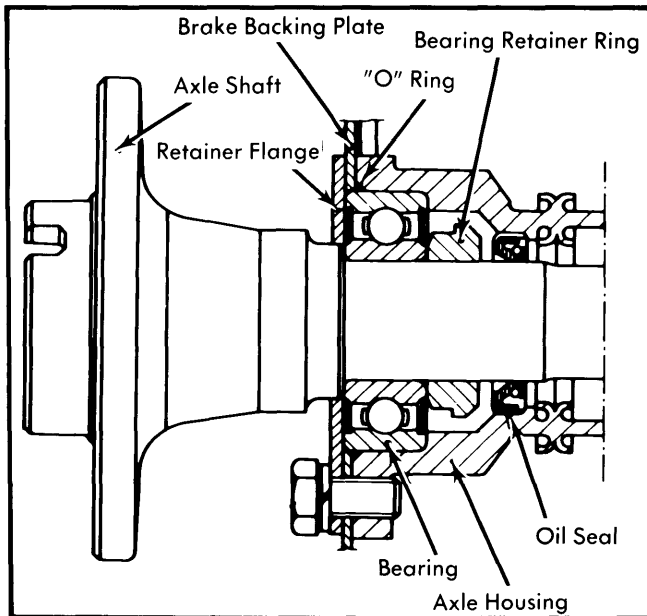

Fig. 1 Sectional View of Brava Axle Shaft and Bearing Assembly

2) Attach slide hammer to axle flange and pull axle from housing using care to guide the brake backing plate off the axle as it is extracted.

3) Remove axle bearing from shaft using an arbor press and suitable support tools. Discard axle shaft bearing retainer. Inspect retainer seat on axle shaft and if seat is scored or damaged, replace axle shaft.

Installation — 1) Place retainer flange and bearing on axle shaft. Heat bearing retaining ring to about 600°F (300°C) and place heated retainer on axle shaft.

2) Using an arbor press and appropriate support tools, press bearing retainer onto shaft until bearing is locked between retainer and shoulder on axle shaft.

NOTE — Do not exceed 13,000 lbs. (57,824 N) force with press, as damage to axle shaft assembly may occur.

3) If axle is to be installed at this time, replace oil seal inside axle housing (if required), and install axle in reverse order of removal.

REAR AXLE ASSEMBLY

Removal (Brava) — Raise and support vehicle. Remove rear wheels and disconnect brake system components. Disconnect spring from bracket and support. Pull cable housings back and remove cable from bracket. Slide cable out of support. Disconnect brake hose from "T" connector. Slip brake compensator torsion bar out of slot in bracket.

Removal (Spider) — Raise and support vehicle. Remove rear wheels and disconnect brake system components. Disconnect brake hose from "T" connector. Remove bolt, washers and nut holding link for brake compensator to bracket. Disconnect hand brake cable from both calipers.

Installation — Reverse removal procedure then bleed the brake system and check for proper operation of parking brake.

OVERHAUL

DISASSEMBLY

NOTE — Overhaul of differential assembly can be accomplished with rear axle assembly installed in vehicle.

Differential Case Assembly — 1) Raise and support vehicle, remove axle shafts as previously described and separate propeller shaft from drive pinion flange. Drain lubricant from housing and remove rear housing cover.

2) Mark differential bearing caps for reference at time of reassembly. Remove bearing caps. Install spreader tool (KM-

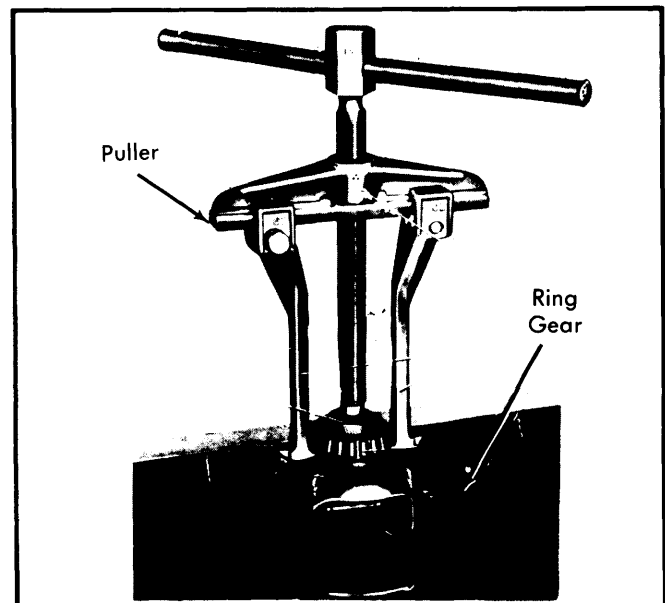

Fig. 2 Removing Differential Bearings from Case

FIAT BRAVA & SPIDER 2000 (Cont.)

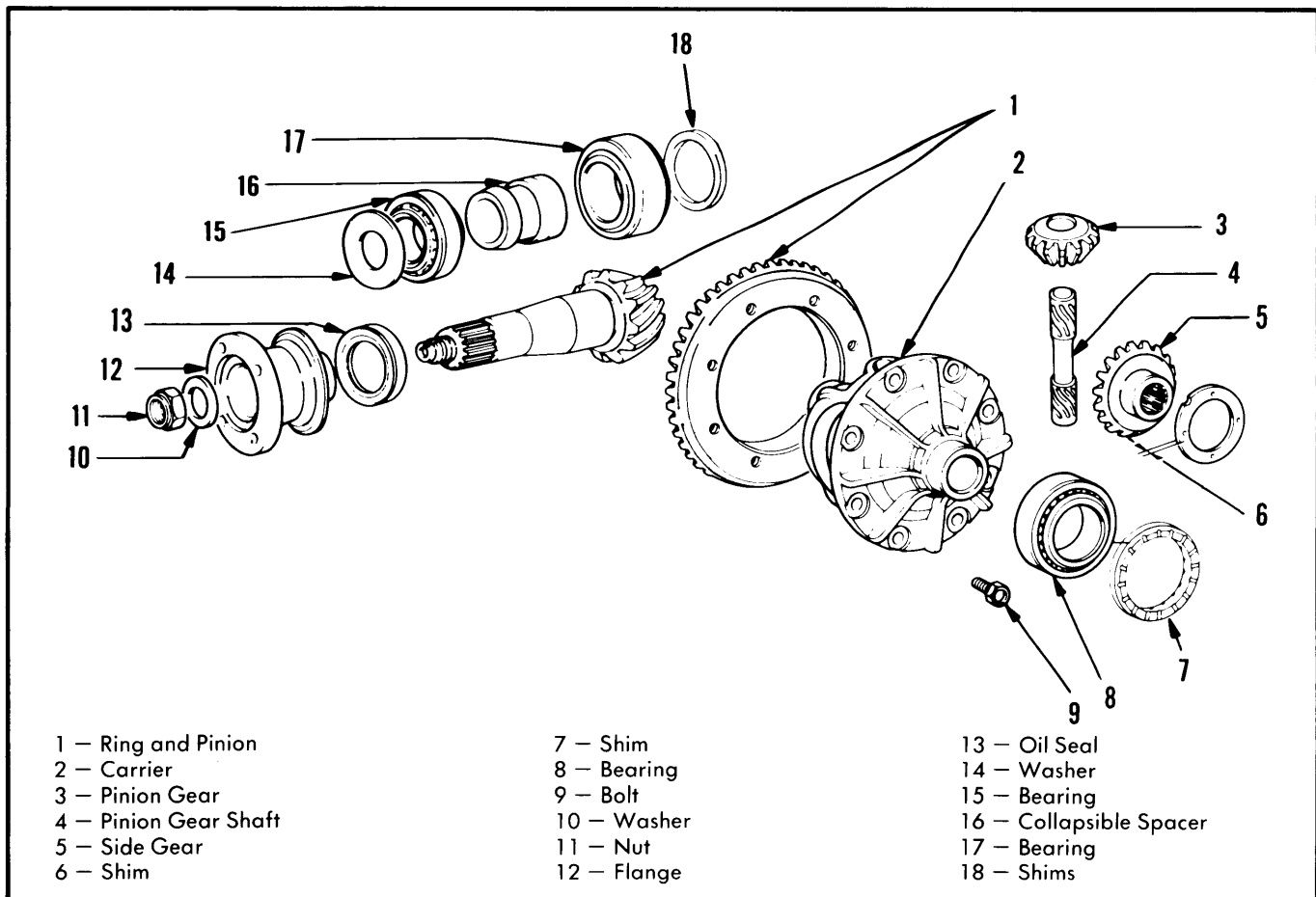

Fig. 3 Exploded View of Brava & Spider 2000 Differential Assembly

28294) on housing. Spread housing and remove differential case along with bearings and shims, noting position of bearing outer race and shims and keeping all left and right side components separated.

3) Using a puller, remove differential bearings from case. Keep bearings separated with other components. Put locating reference marks on ring gear and case, then remove eight ring gear-to-case retaining bolts and remove ring gear.

4) Using a soft drift, drive differential pinion gear shaft out of case. Remove pinion gears, side gears, and side gear thrust washers.

Drive Pinion Gear — Hold drive pinion flange and remove flange nut and flange from drive pinion gear. Remove oil seal and dust shield from pinion shaft then push drive pinion gear out rear of housing. Remove drive pinion bearing outer races from housing. Using an arbor press, remove rear bearing from drive pinion shaft and retain shims found between bearing and gear.

REASSEMBLY & ADJUSTMENT

Drive Pinion Gear — 1) Install pinion bearing outer races in rear axle housing. Before installing rear bearing on drive pinion gear, establish pinion depth adjusting shim thickness as follows (all values given are in hundredths of a millimeter):

NOTE — If the original ring and pinion gears will be used for reassembly, and ring-to-drive pinion gear tooth contact pattern is satisfactory, use original shim(s).

Note marking on original drive pinion shaft. Measure original shim thickness and add it to the value given on the pinion shaft to establish the nominal dimension.

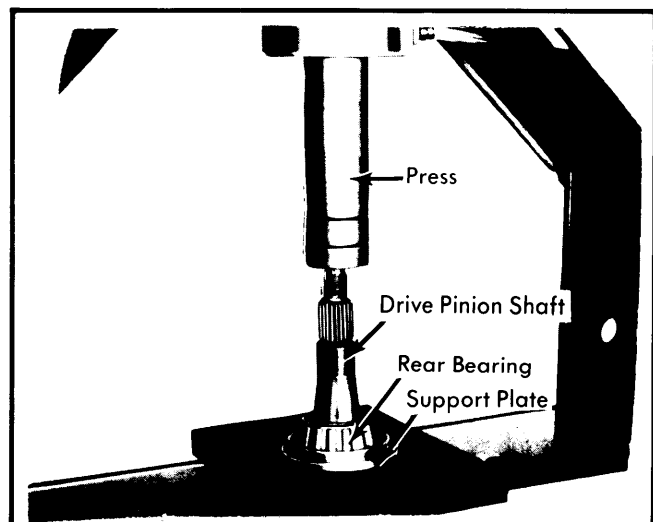

Fig. 4 Removing Rear Bearing from Drive Pinion Gear

Drive Axles

FIAT BRAVA & SPIDER 2000 (Cont.)

Example: Pinion marking is +10 and original shim thickness is 2.90. Nominal dimension is 3.00 (2.90 plus +10).

Note marking on new pinion gear and subtract this value from the established nominal dimension and this will give you the new required shim thickness.

EXAMPLE: Nominal dimension is 3.00 and marking on new drive pinion is +20, then new shim thickness is 2.80 (3.00 minus +20).

2) Place new (or original) pinion depth adjusting shim on drive pinion gear. Press rear bearing on drive pinion gear. Lubricate bearing and install drive pinion and bearing in housing. Install new collapsible spacer, front pinion bearing, dust shield, new oil seal and pinion flange in housing.

3) Start pinion flange nut on shaft and as nut is tightened, keep checking rotating torque of pinion shaft (pinion bearing preload) using an inch pound torque wrench. Tighten nut until pinion bearing preload is within specifications.

NOTE — If pinion bearing preload torque is exceeded, do not back off nut to obtain preload. Install new collapsible spacer and repeat procedure.

Differential Case Assembly — 1) Place thrust washers on side gears and install side gears in case. Install pinion gears by rolling them into position and install pinion shaft. Check rotating torque of one side gear while holding the other. If torque is not to specification, install new thrust washers on side gears.

NOTE — Thrust washers are available in thicknesses from .0709" (1.80 mm) to .0817" (2.10 mm) in increments of .002" (.05 mm).

2) Install ring gear on case and tighten bolts to specified torque. Press differential bearings onto case, and if using original bearings, spread housing and install case using original shims. If using new bearings or case, install case in housing and insert enough shims equally on both sides to eliminate any end play.

3) Install bearing caps and bolts and tighten bolts. Measure ring gear backlash using a dial indicator mounted to housing with plunger contacting ring gear at a right angle to the ring gear teeth. Block drive pinion flange from turning. Zero dial indicator. Rotate ring gear back as far as possible and note backlash reading on indicator. If backlash is not within specification, adjust backlash by changing size of shims. To increase backlash, increase size of shim on pinion side of carrier, and to decrease backlash, increase size of shim on ring gear side of carrier. When changing shims, be sure to install shims of equal size to opposite side of carrier.

4) After determining correct shims to be used, add .002" (.05 mm) more shim thickness to each side. Install spreader on housing, spread housing and install bearing outer races and shims. Remove spreader and install bearing caps and tighten bolts. With differential completely assembled, check ring-to-pinion gear tooth contact pattern to ensure all adjustments are correct.

AXLE ASSEMBLY SPECIFICATIONS

Application	Specification
Pinion Bearing	
Preload	14-17 INCH Lbs. (1.5-1.9 N·m)
Ring Gear Backlash003-.005" (.08-.13 mm)
Side Gear Rotating Torque	22-36 Ft. Lbs. (30-49 N·m)
Differential Bearing	
Preload	⓪Slip Fit Plus .004" (.10 mm)
① — .002" (.05 mm) on each side of differential case.	

TIGHTENING SPECIFICATIONS

Application	Ft. Lbs. (N·m)
Axle Shaft Retaining Flange Bolts	36 (49)
Cover-to-Housing Bolts	18 (24)
Differential Bearing Cap Bolts	36 (49)
Ring Gear-to-Case Bolts	72 (98)