

Drive Axles

DATSUN SEPARATE CARRIER

200SX
210
510
810 Wagon
Pickup (Rear Axle)

DESCRIPTION

Differential gear carrier assembly has a hypoid type ring and pinion gear set. The gear carrier is constructed of cast iron. The drive pinion is mounted in 2 tapered roller bearings that are preloaded by a collapsible spacer. Drive pinion is aligned into position with a shim located between shoulder on drive pinion and rear bearing. Differential case is supported in carrier by 2 tapered roller side bearings. The side bearings are preloaded by inserting shims between bearings and differential. Case houses 2 side gears that mesh with 2 pinion gears mounted on a lock pin. Pinion and side gears are set in front of thrust washers.

AXLE RATIO & IDENTIFICATION

Datsun does not identify rear axle with a particular outside identification marking, however all models use same basic type of removable carrier rear axle. It should be noted that part or model numbers may vary between vehicle models, but the internal design is similar. Various axle ratios are available depending on model and whether manual or automatic transmission equipped. Ratio may be determined by dividing number of ring gear teeth by number of pinion gear teeth.

REMOVAL & INSTALLATION

AXLE SHAFTS & BEARINGS

Removal — Raise and support vehicle; remove tire and wheel. Disconnect parking brake linkage and hydraulic line. On 200SX, remove brake caliper. On all other models, remove brake drum. Remove brake back plate (dust shield on 200SX) retaining nuts and pull assembly from housing with suitable slide hammer.

Disassembly — Mount axle shaft assembly in a vise or mounting fixture and cut bearing collar with a chisel. On pickups, bend lock tabs away and remove wheel bearing lock nut. On all models, remove wheel bearing with brake back plate (dust shield) using suitable puller.

NOTE — Axle bearings on pickups are tapered roller type. Outer race may be removed from back plate after removing oil seal by tapping out with a brass drift.

Reassembly — On pickups only, fit bearing outer race into position in back plate using brass drift and install oil seal. Pack seal lips with grease and install bearing and nut lock washers. Tighten lock nut to specifications. Bend up lock tabs on washer. On all other models, install bearing spacer, bearing and new collar using suitable press.

Installation — To install, reverse removal procedure and note the following: On all models except pickup, insert axle shaft and adjust gap between wheel bearing and axle tube end to 0-.004" (.1 mm) by installing appropriate shim. See Fig. 2. On pickup models, insert shims between back plate and axle tube end so that measured axle shaft end play is .0008-.006" (.02-.15 mm). On all other models, mount dial gauge and check axle shaft end play. End play should be .002-.016" (.05-.41 mm) on 200SX; .008-.020" (.20-.50 mm) on 810 and .004-.018" (.10-.46 mm) on 210 and 510.

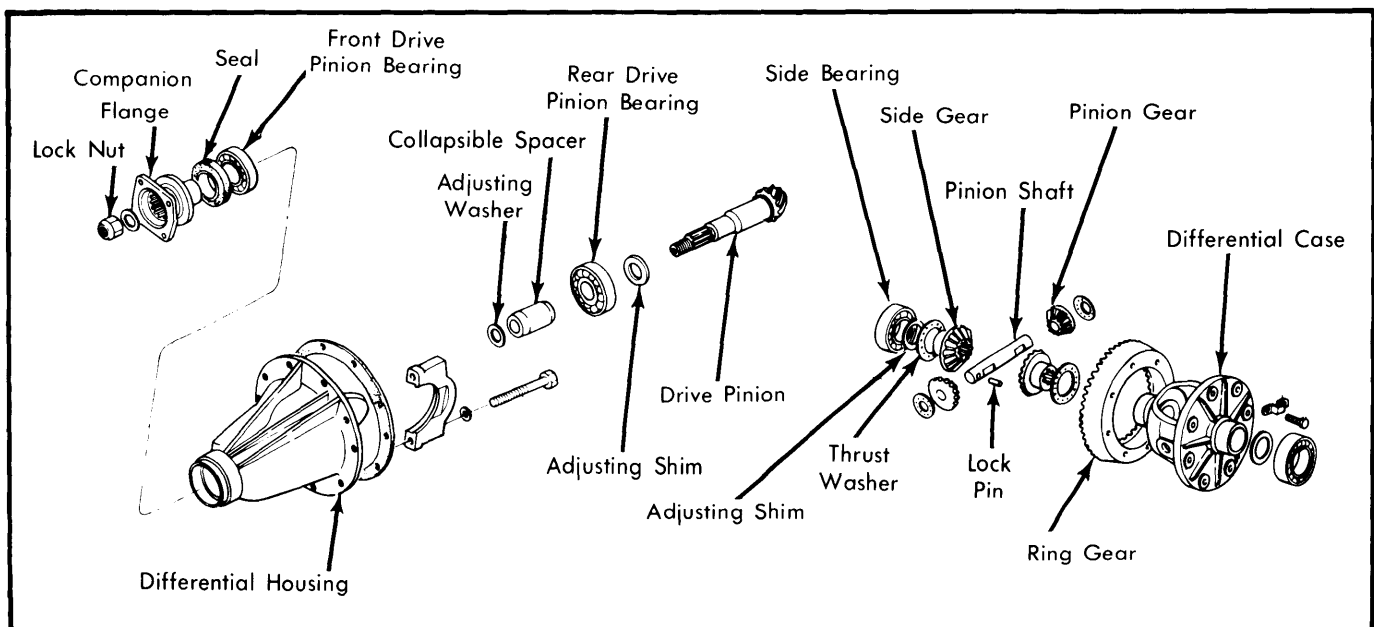

Fig. 1 Exploded View of Datsun Separate Carrier Differential Assembly

DATSUN SEPARATE CARRIER (Cont.)

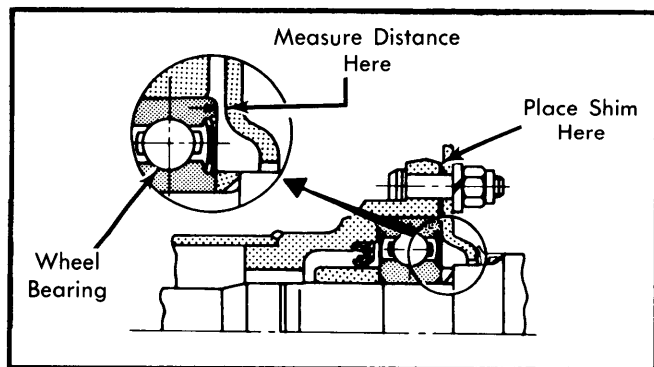

Fig. 2 Location for Checking Clearance Between Wheel Bearing and Axle Tube End on All Models Except Pickup

PINION FLANGE SEAL

Removal — Raise and support rear end of vehicle, then drain gear oil. Index mark propeller shaft and companion flange, then detach shaft and wire out-of-way. Remove drive pinion nut and companion flange. Remove oil seal.

Installation — Set new oil seal into position and pack grease between seal lips. Position companion flange and flat washer on drive pinion, then tighten nut and check bearing preload.

DIFFERENTIAL CARRIER

Removal — Raise and support vehicle on safety stands placed under rear axle housing. Drain gear lubricant. Index mark propeller shaft and remove. Withdraw rear axle shafts as previously described. Remove nuts mounting differential gear carrier to rear axle housing and lift out gear carrier.

Installation — To install differential gear carrier, reverse removal procedure and tighten nuts.

OVERHAUL

DISASSEMBLY

NOTE — Predisassembly inspection of ring gear backlash and gear tooth contact can indicate where possible problems may be oriented. See Gear Tooth Contact at beginning of this section.

Differential — 1) Mount differential carrier in suitable holding fixture, index mark side bearing caps and carrier. Remove bearing caps and lift out differential assembly. Remove drive pinion lock nut and pull companion flange off with a gear puller. Remove drive pinion together with rear bearing inner race, spacer and washer. Drive pinion can be freed by tapping front end of assembly. If necessary, extract oil seal and withdraw front bearing inner race.

2) Use puller (ST30031000) and extract bearing from drive pinion gear. Remove front and rear bearing races using a drift. Disassemble differential case as follows: Using puller (ST33051001), remove side bearings. Keep right and left side components separate for reassembly reference.

3) Bend back ring gear retaining bolt lock tabs and remove bolts by loosening in a diagonal sequence. Tap ring gear off gear case using a soft hammer. Drive out pinion shaft lock pin and remove pinion gears, side gears and thrust washers. Identify gears and thrust washers for installation in original positions.

CLEANING & INSPECTION

Clean all disassembled parts and visually inspect for excessive wear. Check all gears for wear and replace if necessary. Inspect thrust washer surfaces and be sure they are free from surface scratches.

NOTE Drive pinion and ring gear are replaced only as a set.

REASSEMBLY & ADJUSTMENT

Case Assembly — 1) Fit pinion, side gears and thrust washers in differential case. Assemble pinion shaft to differential case so lock pin holes align with shaft. Insert side gear thrust washers of proper thickness to obtain specified clearance between rear face of side gear and thrust washer. Insert pinion shaft lock pin and secure by peening with a punch.

2) Lightly oil gear tooth areas and all thrust surfaces, then check that gears turn freely and smoothly. Fit ring gear on differential case, tighten bolts in diagonal manner and bend over lock tabs. If side bearing is to be replaced, measure thickness of new ones using suitable tool set as shown in Fig. 3. Normal bearing thickness should be as specified. Using a press, seat side bearing cone into differential case.

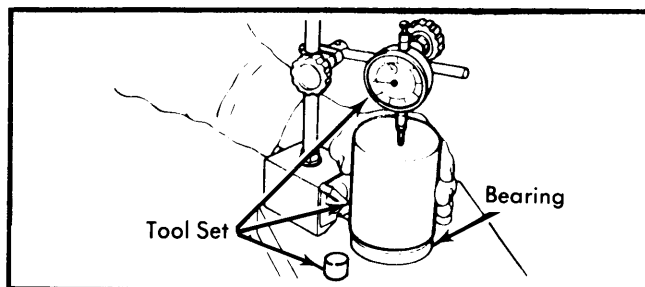

Fig. 3 Measuring Side Bearing Thickness

Drive Pinion Height — 1) Pinion height is adjusted with drive pinion adjusting washer placed behind drive pinion gear. Variation from the standard size to the drive gear center is marked on drive pinion gear head. If tolerance is greater than standard size, number is marked in "+", if less than standard size, marking is "-". Install front and rear drive pinion outer races in gear carrier. Fit drive pinion adjusting washers and rear bearing on suitable dummy shaft. Position dummy shaft in final drive housing without drive pinion adjusting spacer, then put on front pinion bearing and companion flange.

2) Tighten drive pinion nut to specified preload setting. DO NOT overtighten pinion nut. Install suitable drive pinion height gauge on final drive housing and measure clearance between end of gauge and surface of dummy shaft as shown in Fig. 5. To calculate thickness of needed drive pinion adjusting washer, use one of the following formulas:

Drive Axles

DATSUN SEPARATE CARRIER (Cont.)

210
200SX & 510
810 & Pickup

$$T = W + N - (H \times .01) - .18$$

$$T = N - (H - D' - S) \times .01 + 2.98$$

$$T = N - (H - D' - S) \times .01 + 2.18$$

T = Thickness of needed shim.
W = Thickness of temporary shim.
N = Clearance between depth gauge and dummy shaft.
H = Figure stamped on drive pinion head.
D = Figure stamped on dummy shaft.
S = Figure marked on height gauge.

NOTE — Formula values are expressed in millimeters.

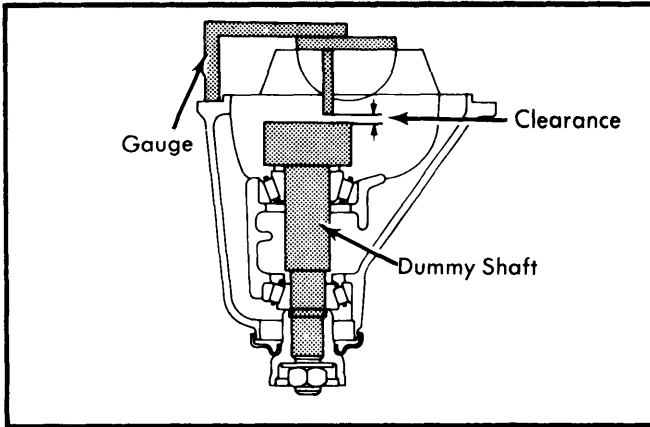

Fig. 4 Checking Drive Pinion Height Adjustment

3) Remove dummy shaft from gear carrier, take out pinion rear bearing from dummy shaft, select correct shims based upon calculations and refit pinion rear bearing and drive pinion. Ensure face side of shims are toward back of pinion gear.

NOTE — Pinion nut, oil seal and collapsible spacer must NEVER be reused. Always use new parts during overhaul.

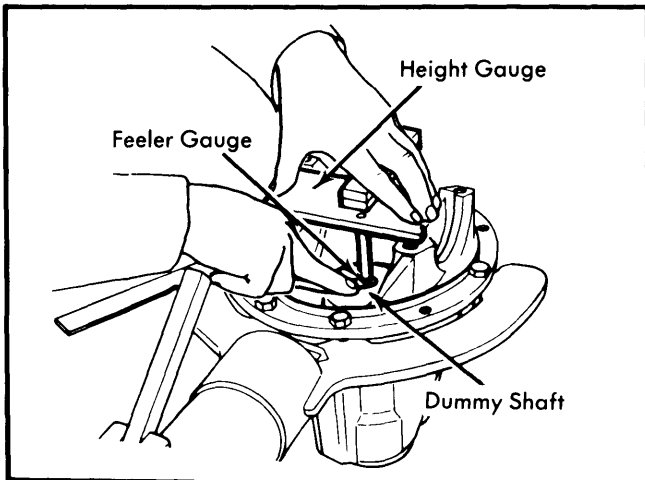

Fig. 5 Measuring Clearance Between Height Gauge and Dummy Shaft

Drive Pinion Preload — 1) After obtaining final pinion bearing height, lubricate front bearing and place into carrier. Fit new oil seal in carrier and fill space between seal lips with grease. Slip new collapsible spacer on drive pinion, then

lubricate pinion rear bearing. Insert companion flange in oil seal while holding flange tightly against pinion front bearing cone.

2) Working from rear of carrier, insert drive pinion into companion flange. Ensure drive pinion threads and mounting nut are dirt free, then holding companion flange, tighten nut. This will pull drive pinion into front bearing cone and flange. When drive pinion is pulled into front bearing cone, bearing end play will be reduced.

3) With end play still in evidence, companion flange will be felt bottoming on collapsible spacer. Slowly turn nut and continuously check end play to ensure bearing preload does not exceed specifications. When end play is eliminated, final preload is being approached. Turn pinion in both directions to seat bearing. Adjust bearing preload to specifications using an INCH lb. torque wrench.

NOTE — Never try to decrease bearing preload by backing off pinion nut; always replace collapsible spacer.

Backlash & Side Bearing Preload — 1) Preload is adjusted with shims. Procedure is done after overhaul work has been completed on differential assembly. When assembling without changing side bearings, install shims of original thickness. If bearings are being replaced, use the following formula to determine the required thickness of adjusting shims:

210 $T1 = (A - C + D - H') \times .01 + .20 + E$
 $T2 = (B - D + H') \times .01 + .20 + F$

200SX & 510 $T1 = (A - C + D - H') \times .01 + .20 + E$
 $T2 = (B - D + H') \times .01 + .09 + F$

810 & Pickup $T1 = (A - C + D - H') \times .01 + .175 + E$
 $T2 = (B - D + H') \times .01 + .150 + F$

T1 = Left shim thickness.
T2 = Right shim thickness.
A = Figure marked on left bearing carrier.
B = Figure marked on right bearing carrier.
C & D = Figure stamped on differential case (+ or - number).
E & F = Deviation from standard bearing thickness.
H' = Figure stamped on ring gear.

NOTE — Formula values are expressed in millimeters.

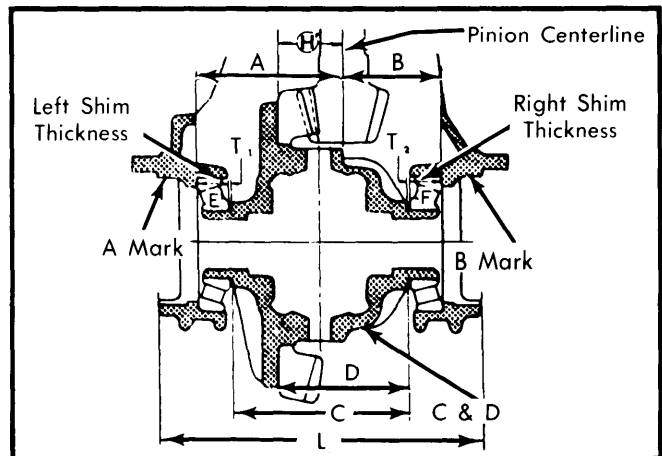

Fig. 6 Calculating Side Bearing Shim Thickness

DATSUN SEPARATE CARRIER (Cont.)

2) Side bearing thickness is measured using a suitable press (ST3250S0000) and applying approximately 5.5 lbs. (2.5 kg). Measure thickness in at least three locations.

3) Fit side bearing shim of differential case and press in both side bearing inner races. Place differential case assembly into gear carrier using a rubber mallet. Align index marks on bearing cap and gear carrier, then install bearing cap on carrier.

4) As a second check, measure distance between bearing caps using a micrometer. See Fig. 7. Specification obtained should be as indicated in table. Correct any deviation with shim of proper thickness.

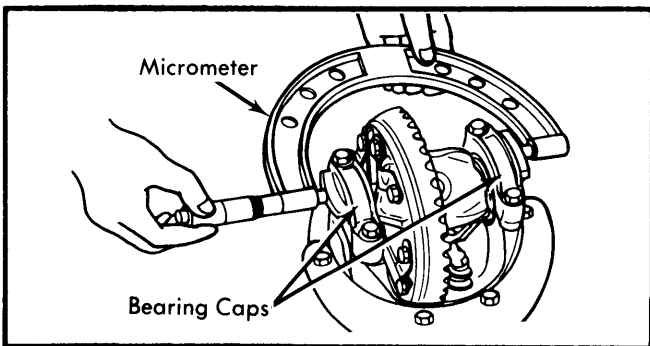

Fig. 7 Measuring Distance Between Bearing Caps

5) Using suitable dial indicator, measure ring gear-to-drive pinion backlash. Measurement should be as indicated in specifications. If backlash is less than specified, decrease thickness of left shim and increase right shim by same amount. If backlash is more than specified, reverse placement of shims in procedure above. Using same dial indicator, check ring gear deflection. Runout should be as specified.

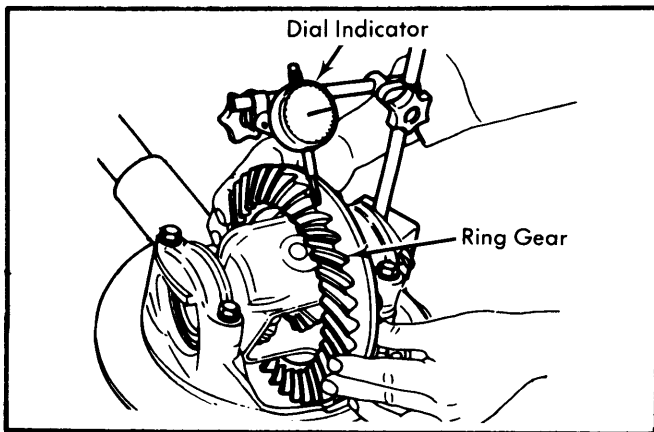

Fig. 8 Measuring Ring Gear Backlash

6) Check side bearing preload by measuring the amount of rotating torque needed to turn companion flange. See Fig. 9. Check gear tooth contact pattern and correct any problem.

NOTE — See Gear Tooth Pattern at beginning of this Section.

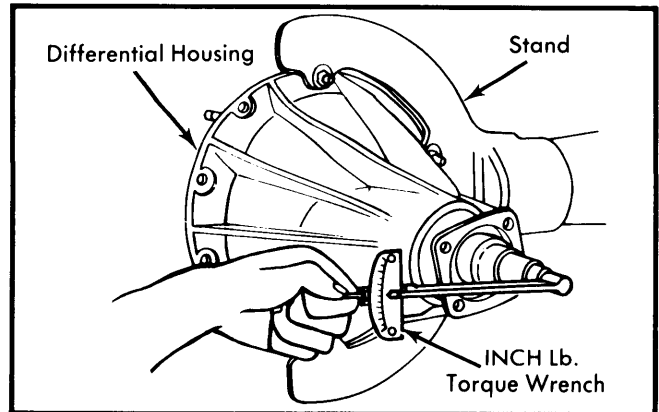

Fig. 9 Measuring Drive Pinion Preload

AXLE ASSEMBLY SPECIFICATIONS

Application	Specification INCH Lbs. (N·m)
Drive Pinion Preload	
With Oil Seal Installed	
200SX & 510	6-9 (.7-1.0)
210	5-7 (.6-.8)
810	6-13 (.7-1.5)
Pickup	9.5-14 (1.1-1.6)
	In. (mm)
Ring Gear-to-Pinion Backlash	
210004-.006 (.10-.15)
200SX & 510005-.007 (.13-.18)
All Others006-.008 (.15-.20)
Pinion Gear-to-Side Gear Backlash	
All Models004-.008 (.10-.20)
Ring Gear Backface Runout	
200SX0016 (.04)
Pickup0031 (.08)
Standard Side Bearing Thickness	
200SX & 5107283 (18.5)
2106890 (17.5)
All Others7874 (20)
Distance Between Bearing Cap Edges	
210	6.039-6.041 (153.40-153.45)
510	6.820-6.822 (173.23-173.29)
810	7.811-7.817 (198.40-198.55)

TIGHTENING SPECIFICATIONS

Application	Ft. Lbs. (N·m)
Drive Pinion Nut	94-217 (127-294)
Ring Gear Retaining Bolts	
200SX, 810 & Pickup	58-72 (78-98)
210	43-51 (59-69)
510	51-58 (69-78)
Side Bearing Cap Bolts	
200SX, 510, 810 & Pickup	36-43 (49-59)
210	40-51 (54-69)
Differential Carrier-to-Axle Housing	
200SX & 810	18-25 (25-34)
210, 510 & Pickup	12-17 (17-24)
Companion Flange-to-Propeller Shaft	17-24 (24-32)