

528i
633CSi
733i

BMW SPLIT HOUSING

DESCRIPTION

Differential has hypoid type ring and pinion gear set, and may have one of two clutch pack type limited slip units. Left side of housing is the housing cover and must be removed to expose carrier assembly. Cover incorporates a ball bearing and oil seal for left axle flange, and a bearing cone for the left differential carrier bearing. Right carrier bearing and seal are incorporated in housing. The pinion gear is supported by roller bearings and preload is maintained by a collapsible spacer.

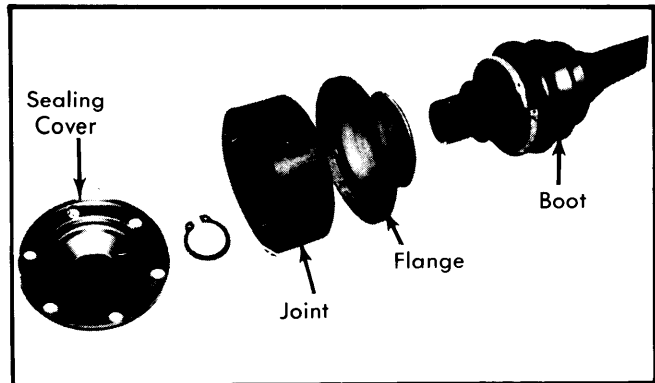

Fig. 2 Exploded View of Half Shaft Constant Velocity Joint

REMOVAL & INSTALLATION

DRIVE SHAFTS & UNIVERSAL JOINTS

Removal — Remove drive shaft after removing retaining bolts from axle and half shaft flanges. Remove cover from joint housing and snap ring from end of drive shaft. Remove clamps from boot then press drive shaft from joint. Remove dust boot.

Installation — To install, reverse removal procedure using sealer on boot-to-joint surfaces, and install seal cover after packing joint with suitable grease.

AXLE RATIO & IDENTIFICATION

Ring and pinion gear set with Klingelnberg tooth design can be identified by the letter "K" stamped on the head of the pinion gear; Gleason teeth are noted by an "H" stamping. To determine axle ratio, divide number of ring gear teeth by number of pinion gear teeth. The number of teeth on ring and pinion, and the code for limited slip differential (S), is stamped on right side of differential housing after ratio indication.

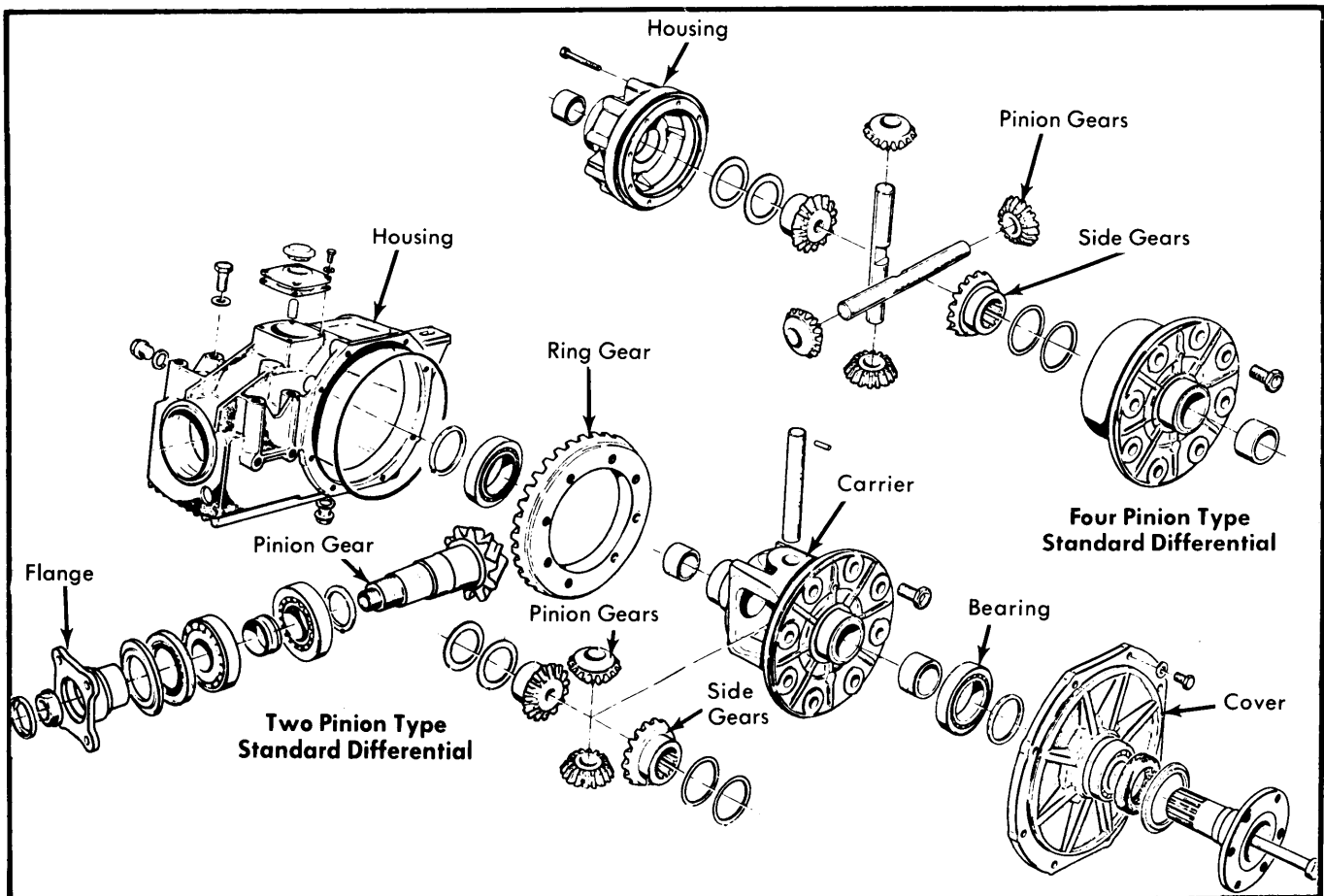

Fig. 1 Exploded View of BMW Split Housing Differential

Drive Axles

BMW SPLIT HOUSING (Cont.)

AXLE SHAFTS & BEARINGS

Removal — Raise and support vehicle. Remove wheel, drive shaft, axle flange retaining nut, and using a puller, (if required), remove axle flange. Using soft headed mallet, drive axle shaft out of housing. Drive out bearings and seals, then remove spacer sleeve and shim.

Installation — 1) To install, reverse removal procedure noting the following: Install outer bearing then determine distance between outer race of outer bearing and shoulder in hub for inner bearing (dimension "B"). Subtract from spacer length (dimension "A") and use shim ("C") to give .004" (0.1 mm) end play. See Fig. 3.

2) Pack bearing with suitable lubricant and lubricate sealing lips. To complete installation, reverse removal procedure.

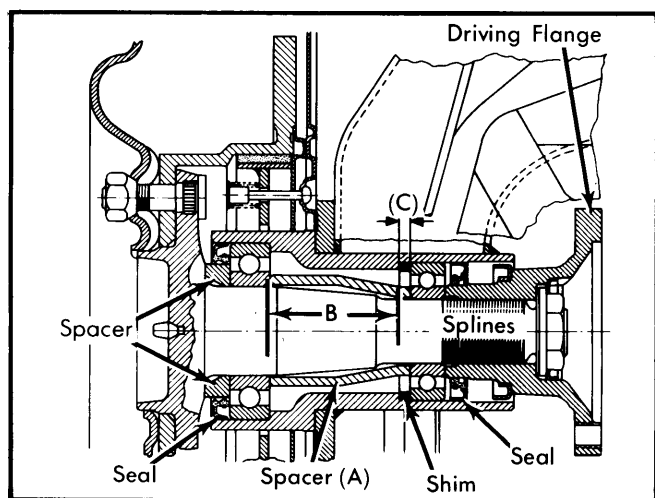

Fig. 3 Wheel Bearings and Axle Shaft

AXLE FLANGE, SEAL & BEARING

Removal — Hold axle flange and remove retaining bolt. Use puller to remove axle flange. Pry out oil seal. Ball bearing may be removed from cover with puller if required.

Installation — To install, reverse removal procedure after packing bearing and seal cavity with suitable lubricant.

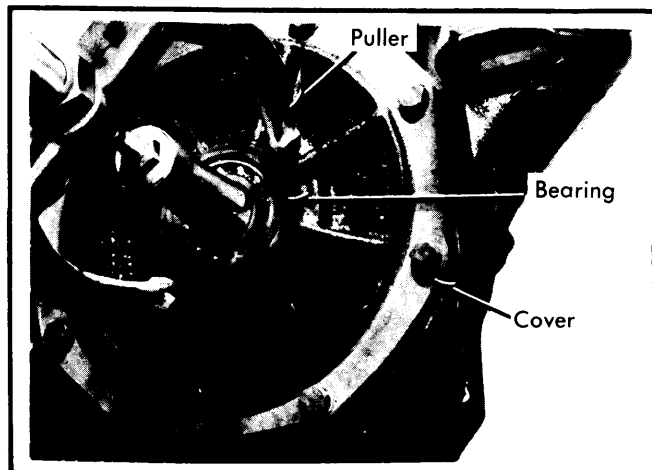

Fig. 4 Removing Drive Flange Ball Bearing

NOTE — On models with circlips and grooves in drive flange shafts, insert circlip in case, and press drive flange in by hand until snap ring engages. Replace loose driving flanges.

DIFFERENTIAL CARRIER ASSEMBLY

NOTE — Differential carrier can be removed from housing with differential assembly installed in vehicle. After removing axle flanges, follow Differential Carrier, Disassembly and Overhaul procedures, in this story.

DIFFERENTIAL ASSEMBLY

Removal — Remove propeller shaft and drive shafts, tie drive shafts up out of way. Support differential and remove bolts securing it to front brackets and rear support. Remove differential assembly.

Installation — To install, reverse removal procedure, insuring rear support is stress free when installed.

OVERHAUL

DISASSEMBLY

Differential Assembly — 1) Remove differential assembly as previously outlined and mount assembly in holding fixture. Drain oil and mark pinion shaft and companion flange for reassembly reference. Remove inspection hole cover, mount dial indicator in one cover bolt hole and check ring gear backface runout and ring-to-pinion gear backlash. Check gear tooth contact pattern.

NOTE — Refer to Rear Axle Gear Tooth Patterns in this Section.

2) Remove axle flanges and side cover, then remove differential carrier assembly. Proceed as follows for standard or limited slip differential carrier disassembly.

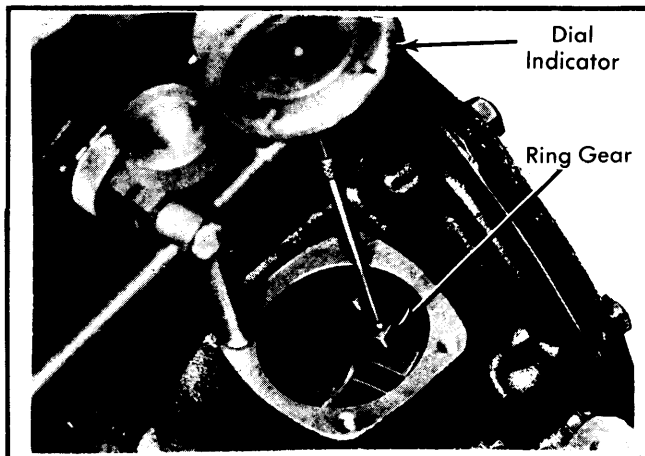

Fig. 5 Checking Ring Gear Backlash

Standard Two Pinion Differential Carrier — Remove carrier bearings with puller and separate ring gear from carrier. Drive out pinion shaft lock pin and differential shaft. Remove pinion gears, side gears with shims, and thrust washers.

Standard Four Pinion Differential Carrier — Remove carrier bearings with puller and separate carrier halves. Lift out pinion gears and shafts, then remove side gears with shims and thrust washers. Unbolt and remove ring gear from carrier.

BMW SPLIT HOUSING (Cont.)

Limited Slip Differential Carrier — Remove carrier bearings with puller. Unscrew case cover bolts and remove case cover. Invert case and lift off of clutch and gear assembly. Remove ring gear.

Drive Pinion Gear — 1) Remove differential carrier as previously described, then check pinion bearing preload using an inch pound torque wrench. Remove pinion flange nut lock ring, hold flange and remove nut. Press drive pinion out through flange and housing.

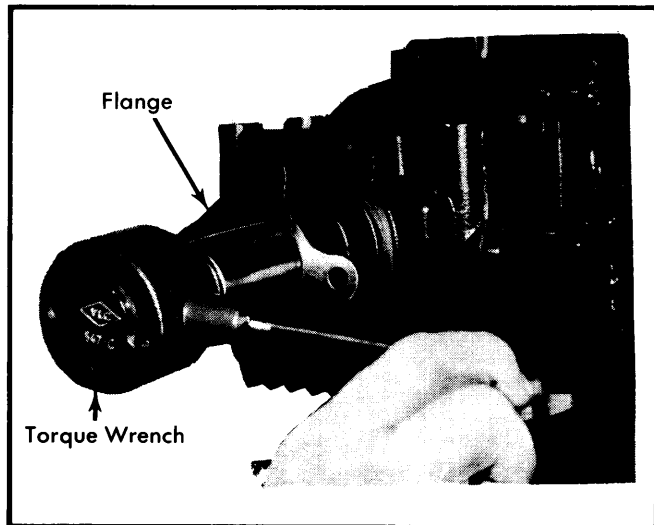

Fig. 6 Checking Pinion Bearing Preload

2) Remove oil seal and lift out front bearing. Remove front and rear bearing races with puller (33 1 350).

REASSEMBLY & ADJUSTMENT

Differential Assembly — Reverse disassembly procedure noting the following checks and adjustments.

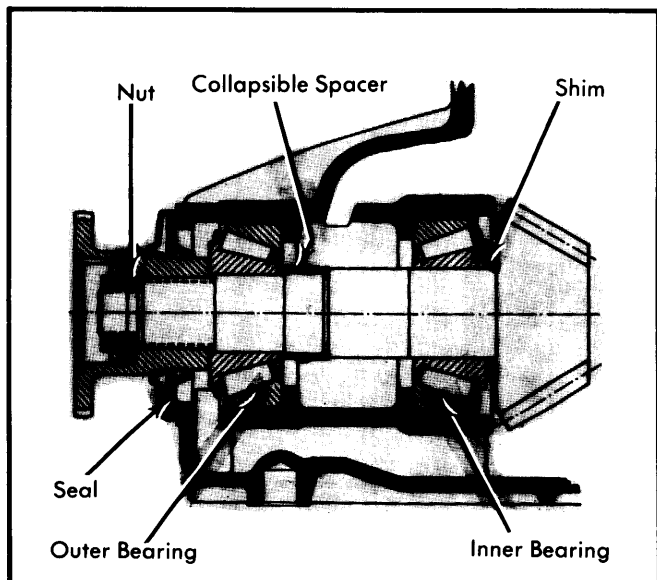

Fig. 7 Sectional View of Drive Pinion Gear and Bearing Assembly

Drive Pinion Bearing Preload — 1) If original ring and pinion gear set is being installed, and gear tooth pattern and pinion bearing preload were satisfactory at time of disassembly, install drive pinion gear using original shim and a new collapsible spacer.

2) If a new gear set is being installed, it will be necessary to determine correct pinion depth shim using gauge block and gauge tool (33 1 400). Place .157" (4.0 mm) thick gauge disc ("A") on pinion and press bearing into position with beveled side of disc toward drive pinion.

3) Install front bearing and drive pinion flange without shaft seal. Tighten pinion shaft nut to give 18-20 INCH lbs. (2.0-2.3 N.m) of rotating torque. Zero dial indicator on gauge tool with .16" (4 mm) preload. Insert gauge assembly in housing.

4) Measured pinion depth (E) is figured by adding gauge block dimension (C) to $\frac{1}{2}$ gauge tool diameter (D) and distance from tool to block (Y). Specified basic pinion depth (E) of Klingelnberg teeth is 2.32" (59.00 mm) and depth of Gleason teeth is 2.43" (61.85 mm).

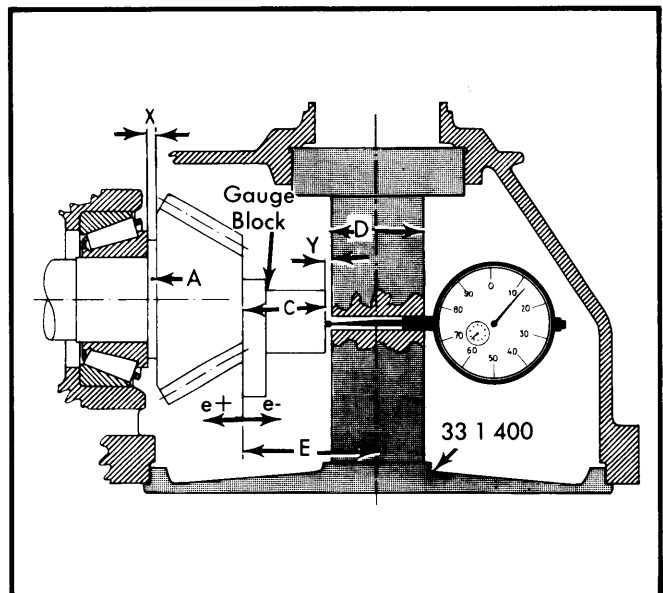

Fig. 8 Measuring Pinion Depth

NOTE — Klingelnberg teeth have a constant depth and flank dimension and are identified by the letter "K" stamped on the ring and pinion gears. Gleason teeth are higher and wider on the outside than on the inside and are marked with the letter "H" or "F" on ring and pinion gears. Individual differences in manufacture of pinions will be stamped or etched on the end of the pinion gear in .01 mm such as -15, indicating that the pinion face is .15 mm closer to the gauge than basic E dimension. This number (e) must be added to (E) if (+) or subtracted if (-) to determine "E" specified.

5) Thickness of shim "X" to be used in final assembly may be determined by comparing "E" measured with "E" specified and adding or subtracting difference (a) to gauge disc thickness. See illustration and sample calculation.

Drive Axles

BMW SPLIT HOUSING (Cont.)

Sample Calculation for Pinion Depth Shim

| | |
|-----------------------------------|-------------------|
| (E) Klingelberg | 2.323" (59 mm) |
| Plus | .006" (.15 mm) |
| Equals (E) Specified | 2.329" (59.15 mm) |
| Difference (a) | .011" (.27 mm) |
| Gauge Disc (A) | -.011" (.27 mm) |
| Equals Shim (X) Requirement | .148" (3.78 mm) |

NOTE — If (E) specified is larger than (E) measured, subtract difference (a) from disc (A) thickness; if (E) specified is smaller, add difference (a) to gauge disc thickness to determine shim (X) thickness.

6) Remove drive pinion and pull off taper bearing. Replace gauge disc (A) with shim (X) of proper thickness, assuring that bevelled inside diameter faces drive pinion. Install collapsible spacer, seal, companion flange and collared nut to obtain specified drive pinion preload.

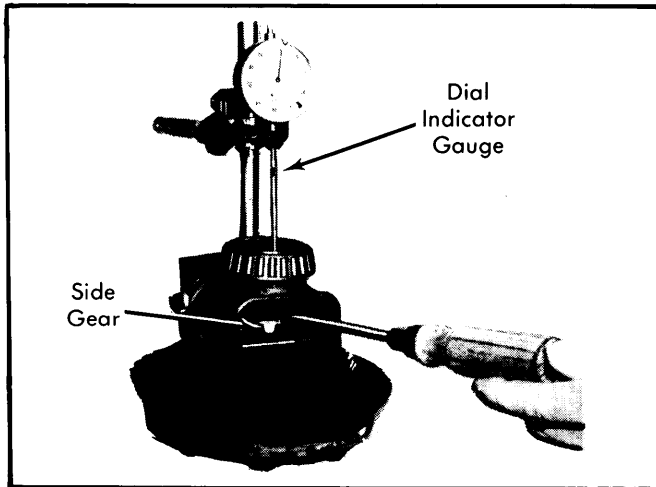

Fig. 9 Checking Side-to-Pinion Gear Backlash

NOTE — If preload is exceeded, new collapsible spacer must be installed and the procedure repeated. Seal should be lubricated with gear lube prior to installation.

Side-to-Pinion Gears Backlash (Std. Differential) — Install 2 pinion gears with shaft and 1 side gear. Mount dial indicator to carrier so plunger contacts side gear. Force side gear hard against case. With proper shim and thrust washer, backlash should be as specified, and preload of all 3 gears should not exceed specified value. Repeat procedure on opposite side (with second set of pinions on 4 pinion type). Retain side gears pressed outward against carrier so axle flange retaining bolts can be later be installed.

Limited Slip Differential Clutch Assembly — 1) Install in order: outer plates, inner plates, pressure rings, rear axle shaft gears, differential shaft gears and differential shafts. Measure installed height (A) from case edge to outer plate.

2) Measure distance (B) from inner face of side cover to flange surface. Place diaphragm springs together and measure thickness (C). Cover and spring thickness (B+C) must be from .004" to .016" (0.1 to 0.4 mm) less than installed height (A). If not within these specifications, correct with outer plates of proper thickness.

3) Remove parts from case and install stepped disc with smooth side facing case, diaphragm spring with concave side facing differential shaft, and thrust washer with oil pockets facing inboard. Complete assembly and tighten to specification.

4) Install axle flanges in carrier and clamp one flange in a vise. Use torque wrench to check breakaway torque of assembly. If not within specifications, install thicker or thinner outer plates.

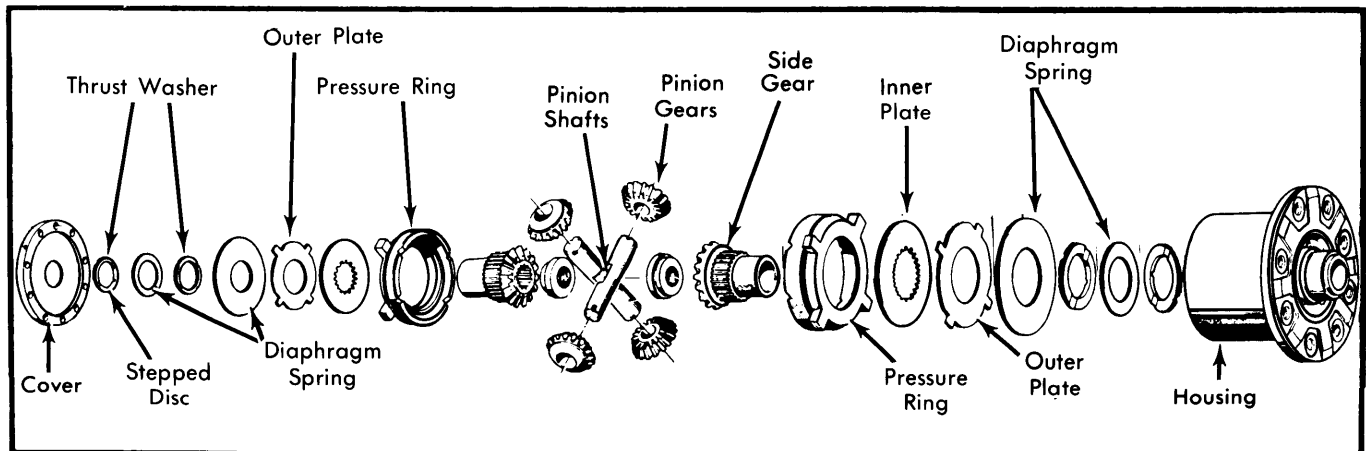

Fig. 10 Exploded View of Limited Slip Differential

BMW SPLIT HOUSING (Cont.)

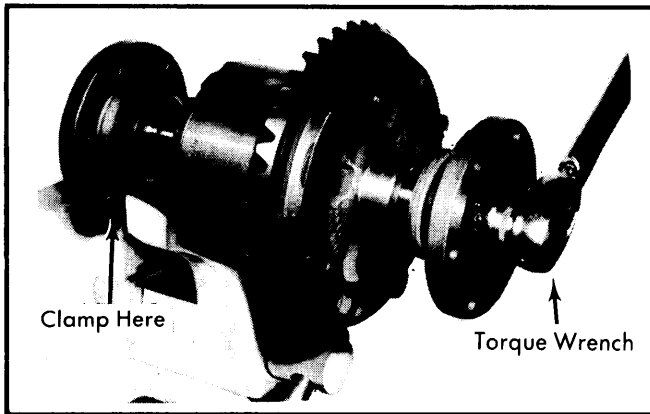

Fig. 11 Checking Torque on Limited Slip Differential

Differential Bearing Preload — 1) Install one shim behind carrier bearing outer cone in side cover. Install bearing cone using installer (33 1 350). Install drive flange bolt without flange so it contacts pinion gear shaft. Install carrier in housing without ring gear and tighten cover mounting screws evenly to specifications.

2) Check minimum rotating torque of 19 INCH lbs. (2.1 N.m). If torque is less than specified, install thicker shim under bearing race in cover. Use feeler gauge to determine gap between cover and case. Subtract this thickness from shim used under bearing race to determine actual shim pack to be used in final assembly. Install ring gear warm (176-212°F) using compound on bolts.

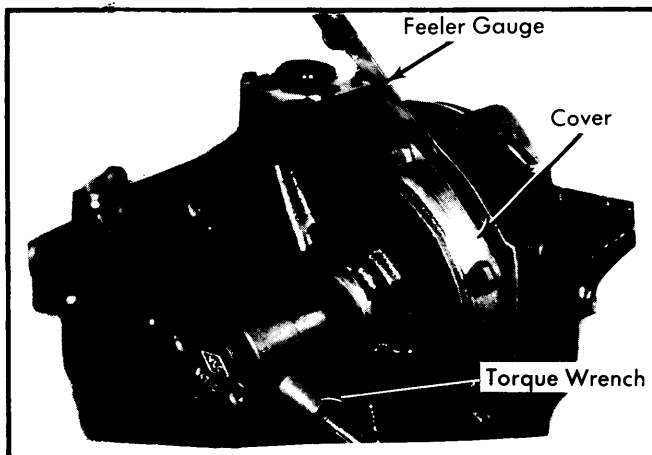

Fig. 12 Measuring Cover-to-Case Clearance for Preload Shim Pack Requirements

Ring-to-Drive Pinion Gear Backlash — 1) With differential bearing preload set, remove inspection hole cover, mount dial indicator in one cover bolt hole, and check ring-to-pinion gear backlash. Check ring gear tooth contact pattern.

NOTE — Refer to Rear Axle Gear Tooth Patterns in this Section.

2) While maintaining established shim thickness, move shims behind carrier bearing outer cones, from one side to the other as necessary to obtain proper contact pattern. After setting backlash, complete differential reassembly procedure.

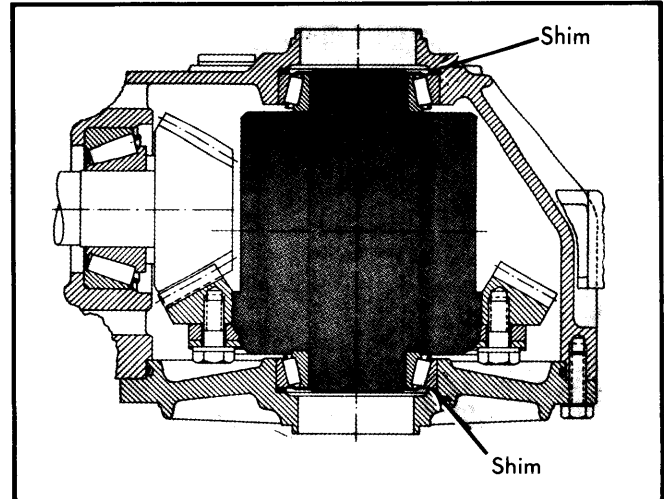

Fig. 13 Sectional View Showing Ring Gear Backlash Shim Locations

AXLE ASSEMBLY SPECIFICATIONS

| Application | Specification |
|---|-------------------------------|
| Wheel Bearing End Play | .002-.004" (.05-.10 mm) |
| Differential Gear Rotating Torque (At Flange) | |
| Standard | 19-34 INCH lbs. (2.1-3.8 N.m) |
| Limited Slip | 36-54 Ft. lbs. (49-73 N.m) |
| Axle Drive Flange End Play | .002-.004" (.05-.10 mm) |
| Ring-to-Pinion Gear Backlash | .002-.004" (.05-.10 mm) |
| Drive Pinion Gear Bearing Preload | |
| Without Seal ① | 28 INCH lbs. (3.2 N.m) |
| With Oil Seal ① | 29 INCH lbs. (3.3 N.m) |
| Limited Slip Clutch Assembly | |
| Case-to-Plate End Play | .004-.016" (.10-.40 mm) |
| Differential Gear Backlash ② | .0012-.004" (.03-.10 mm) |

① — Maximum torque.

② — 528i — 0-.0027" (0-.07 mm).

TIGHTENING SPECIFICATIONS

| Application | Ft. Lbs. (N.m) |
|-----------------------------------|-------------------|
| Housing Cover Bolts | 15-18 (20-24) |
| Ring Gear-to-Carrier Bolts | 121-143 (165-198) |
| Drive Pinion Flange Nut | 111 (151) |
| Drive Shaft-to-Drive Flange Bolts | 65-72 (88-98) |
| Drive Shaft-to-Axle Flange Bolts | 44-48 (60-65) |
| Differential Carrier Cover Bolts | 15-18 (20-24) |
| Axle Flange Nut | 295-332 (401-451) |
| Final Drive-to-Rear Axle Carrier | 53-58 (72-79) |
| Final Drive-to-Rubber Mount | 53-58 (72-79) |