

TRIUMPH

TR7
TR8

DESCRIPTION

Clutch is dry, single plate, diaphragm spring type. Clutch actuation is hydraulic, using a firewall mounted master cylinder and a clutch housing-mounted slave cylinder. Due to self-adjusting feature of clutch assembly, no adjustment, with the exception of bleeding hydraulic system, is necessary.

REMOVAL & INSTALLATION

CLUTCH ASSEMBLY

Removal (TR7) – 1) Raise and support vehicle. Disconnect battery ground cable. Remove gear shift lever assembly. Index mark and separate propeller shaft from transmission. Disconnect exhaust pipe at intake manifold (pipe may have to be completely removed).

2) Disconnect speedometer cable and all electrical wires attached to transmission. Remove starter heat shroud. Place a jack (with wood block) under oil pan. Remove slave cylinder without disconnecting fluid line. Hang cylinder out of way.

3) Remove 2 bolts holding oil pan plate to clutch housing. Remove 4 nuts keeping transmission rear crossmember to body. Slightly lower engine. Remove starter.

4) Remove nuts and bolts mounting clutch housing to engine. Support transmission with appropriate jack. Slide back transmission/clutch housing assembly and remove from vehicle.

5) Index mark pressure plate with flywheel. Loosen 6 pressure plate mounting bolts evenly (a few turns at a time). Slide out pressure plate with clutch disc.

Removal (TR8) – 1) Disconnect battery. Remove gear shift lever assembly. Raise and support vehicle. Remove exhaust system, leaving tail pipes loosely in place. Disconnect oxygen sensors (if so equipped). Index mark and separate propeller shaft from transmission. Place a jack (with wood block) under oil pan. Raise engine.

2) Remove 2 bolts holding oil pan plate to clutch housing and bolt holding clutch pipe to rear engine plate. Remove heat shield and slave cylinder without disconnecting fluid line. Support cylinder out of way. Remove nuts attaching transmission rear crossmember to body. Lower engine.

3) Disconnect and remove speedometer cable. Disconnect wiring harness plug. Remove all but 3 clutch housing bolts. Remove 4 bolts holding flywheel cover to clutch housing. Support transmission with appropriate jack and remove 3 remaining clutch housing bolts. Slide back transmission/clutch housing assembly and remove from vehicle.

4) Index mark pressure plate with flywheel. Loosen 6 pressure plate mounting bolts evenly (a few turns at a time). Slide out pressure plate with clutch disc.

Installation (All Models) – Reverse removal procedure and note the following: Ensure index marks on pressure plate align with those on flywheel. Use clutch aligning tool to center clutch disc. Tighten clutch bolts evenly and gradually.

CLUTCH MASTER CYLINDER

Removal – 1) Disconnect hydraulic line and drain fluid. Plug open port and line.

2) Disconnect clevis mounting push rod to clutch pedal.

3) Remove 2 nuts mounting master cylinder to firewall and remove master cylinder.

Installation – Reverse removal procedure and bleed hydraulic system.

CLUTCH SLAVE CYLINDER

Removal – Raise and support vehicle. Disconnect and plug hydraulic line and remove slave cylinder.

NOTE – Do not move operating rod in a forward direction. Forward movement may cause release lever to dislodge. Transmission removal would then become necessary for installation of release lever.

Installation – Reverse removal procedure and note: Slave cylinder must be mounted with bleed screw ABOVE fluid pipe. Bleed hydraulic line.

CLUTCH RELEASE BEARING

Removal – With transmission assembly removed, use crow's foot wrench and remove clutch release lever pivot from clutch housing. Remove release lever, complete with pivot bolt and release bearing.

Installation – Reverse removal procedure, making sure fork and collar engage evenly.

OVERHAUL

CLUTCH MASTER CYLINDER

Disassembly – 1) Remove master cylinder. Pull up rubber boot and remove snap ring. Slide out push rod and washer.

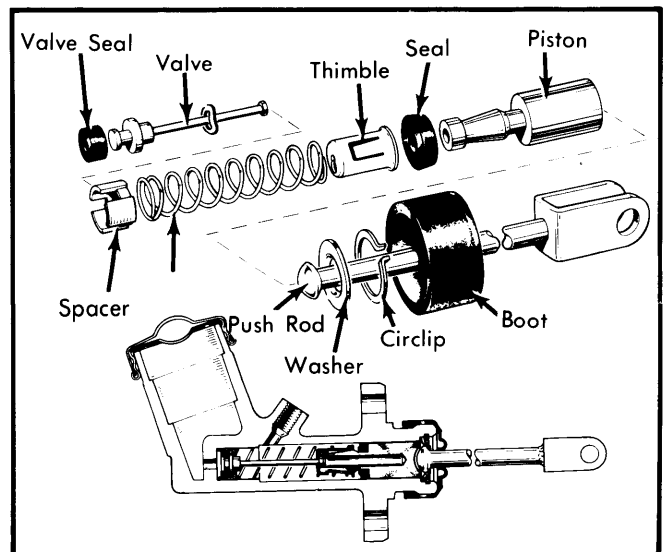

Fig. 1 Exploded View of Master Cylinder

Clutches

TRIUMPH (Cont.)

2) Pull out piston, spring, and seal as an assembly. It may be necessary to use air pressure to force out assembly.

3) Straighten spring thimble prong, then remove thimble and spring from piston. Disengage valve stem from slot in thimble. Slip spacer off valve stem. Remove valve seal.

Reassembly — 1) Fit spacer, spring and thimble to valve stem. Fit new seal to piston with lip facing spring. Put spring thimble on piston and depress thimble prong.

2) Lubricate master cylinder bore with brake fluid and slide seal assembly, spring and piston into place. Reverse disassembly procedure to assemble remaining components.

CLUTCH SLAVE CYLINDER

Disassembly — Remove slave cylinder and pull off dust cover. Remove circlip, then take out piston, seal and spring.

Inspection — Look at cylinder bore and piston for signs of damage. Replace either or both parts if wear is excessive.

Reassembly — Reverse removal procedure, lubricating parts with brake fluid and fitting small end of spring to piston.

ADJUSTMENT

HYDRAULIC SYSTEM BLEEDING

1) Fill master cylinder. Attach bleed tube to bleed valve on slave cylinder. Submerge free end of tube in container of brake fluid.

2) Slowly depress pedal to force air out. Close bleed valve and let pedal rise unassisted. Check that fluid level does not drop too low, and repeat until no more air bubbles are visible.

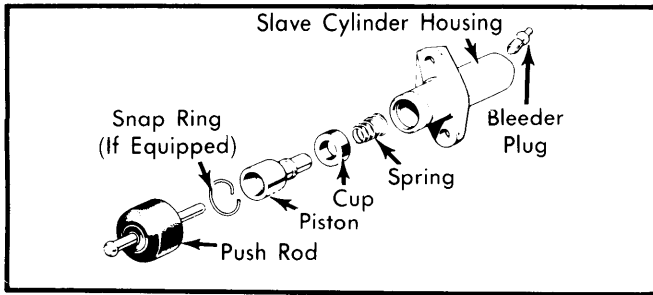

Fig. 2 Exploded View of Slave Cylinder

TIGHTENING SPECIFICATIONS

Application	Ft. Lbs. (N·m)
Clutch Assembly-to-Flywheel	22 (30)
Clutch Housing-to-Transmission	32 (44)
Slave Cylinder-to-Clutch Housing	21 (29)