

Clutches

TOYOTA LAND CRUISER

DESCRIPTION

Clutch is a dry single disc type using a diaphragm type pressure plate. Clutch is hydraulically operated by a firewall mounted master cylinder and a clutch housing mounted slave cylinder. A prelubricated sealed release bearing is used.

REMOVAL & INSTALLATION

CLUTCH ASSEMBLY

Removal — 1) Drain transmission oil, transfer case oil, and fuel tank. Remove transmission undercover and disconnect front and rear driveshafts, power take-off shaft, speedometer cable and parking brake cable. Remove front seat with frames and console box. Remove rear heater tube clamp and shift lever knobs.

2) Remove fuel tank cover and fuel tank. Remove shift lever dust boots and transmission cover. Disconnect front drive indicator wire harness, transfer switch wire harness, and vacuum hoses (if equipped). Disconnect back-up light switch harness.

3) Using suitable tool (09305-60010), remove shift lever hold down nut and lift out shift lever. Support transmission assembly with rope and floor jack. Remove bolts attaching transmission to engine and lower assembly from vehicle.

4) Disconnect clutch fork return spring and remove slave cylinder, but do not disconnect hydraulic line unless necessary. Remove release bearing retaining clips, and release bearing with collar. Remove clutch lever assembly.

5) Mark pressure plate and flywheel for reassembly reference. Loosen clutch attaching bolts one turn at a time until spring pressure is released, then remove bolts and clutch assembly

Installation — To install, reverse removal procedure and note the following: Use suitable aligning tool to center disc on flywheel. Tighten clutch attaching bolts alternately and evenly. After reinstallation, adjust clutch fork free play and bleed hydraulic system if necessary.

CLUTCH MASTER CYLINDER

Removal — Remove clevis pin connecting master cylinder push rod to clutch pedal. Disconnect hydraulic line from cylinder body and plug opening. Remove cylinder attaching bolts at firewall and remove master cylinder.

CAUTION — Do not allow fluid to spill on painted surfaces.

Installation — To install, reverse removal procedure, adjust pedal height and clutch pedal free play, and bleed hydraulic system. Check hydraulic system for leaks.

CLUTCH SLAVE CYLINDER

Removal — Plug master cylinder reservoir cap. Disconnect clutch return spring from hanger. Disconnect flexible hose from metal line and remove clip. Remove slave cylinder retaining bolts and remove slave cylinder.

Installation — To install, reverse removal procedure, adjust clutch fork free play and bleed hydraulic system.

CLUTCH RELEASE BEARING

Removal & Installation — With clutch assembly removed, remove release bearing from hub with suitable bearing remover/installer (0931500021). To install bearing, lubricate with multi-purpose grease and seat bearing with the remover/installer.

PILOT BEARING

Removal & Installation — With clutch assembly removed, check pilot bearing in end of crankshaft for roughness or noise during rotation. If defective, remove using a suitable puller (09303-55010). To install, lubricate bearing with multi-purpose grease and insert into crankshaft using driver (09304-47010).

OVERHAUL

CLUTCH MASTER CYLINDER

Disassembly — With master cylinder removed from vehicle, drain fluid from reservoir and remove push rod, boot and snap ring as an assembly. Using a deep socket, remove reservoir retaining nut and lift reservoir from master cylinder. Pull piston assembly from master cylinder.

Cleaning & Inspection — Wash all parts in clean brake fluid and inspect for wear or damage. Replace master cylinder if scored or worn excessively.

Reassembly — Use cylinder overhaul kit and soak all parts in clean brake fluid. Assemble in reverse order of disassembly. Fill reservoir with fluid and bleed cylinder.

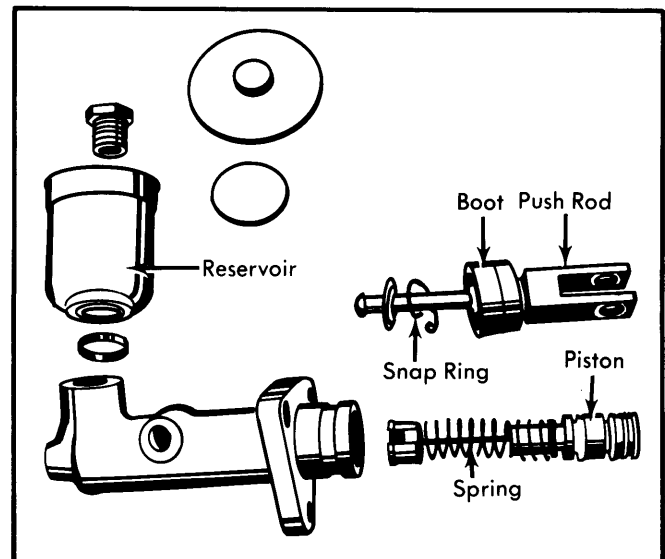

Fig. 1 Exploded View of Clutch Master Cylinder

CLUTCH SLAVE CYLINDER

Disassembly — Remove push rod assembly and rubber boot from cylinder body. Withdraw cylinder piston and cup seal. Loosen and remove bleeder screw.

TOYOTA LAND CRUISER (Cont.)

Cleaning & Inspection – Wash all parts in clean brake fluid and inspect for wear or damage. If slave cylinder bore-to-piston clearance exceeds .006" (.15 mm), replace defective part. Replace piston cups during overhaul.

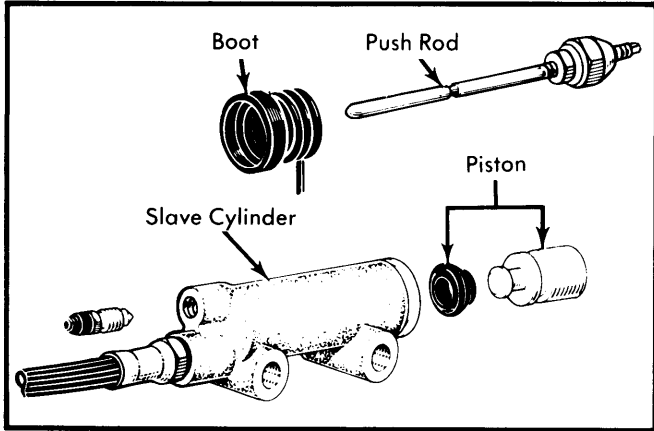

Fig. 2 Exploded View of Clutch Slave Cylinder

Reassembly – Soak all parts in clean brake fluid before reassembly. Reverse disassembly procedure and install boot with protruded part down.

ADJUSTMENTS

PEDAL HEIGHT

Pedal height is measured from floor to top of pedal pad. To adjust, loosen lock nut and turn stop bolt to give pedal height of 8.5" (215 mm).

PEDAL FREE PLAY

Clutch pedal free play is that distance of free movement before master cylinder push rod contacts piston. To adjust, loosen lock nut and turn push rod to obtain 1.9-2.0" (48-51 mm) free play. Tighten lock nut.

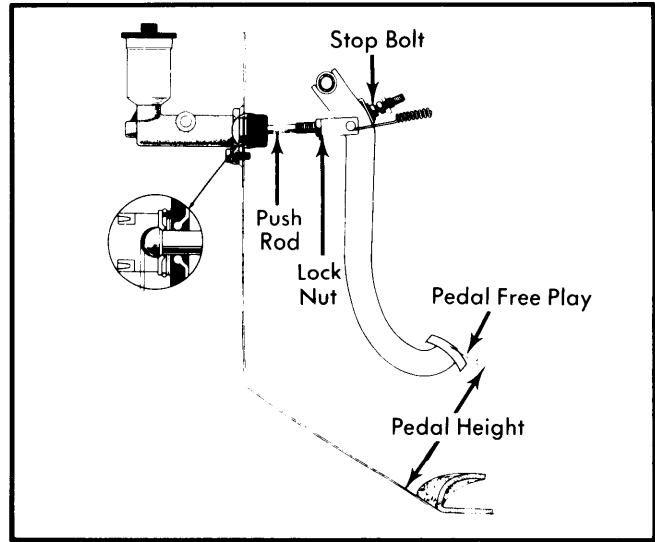

Fig. 3 Pedal Height Measuring and Adjustment Points

CLUTCH FORK FREE PLAY

To adjust clutch fork free play, loosen lock nut at slave cylinder and turn push rod tip while holding push rod nut with suitable wrench. Free play should be .12-.16" (3-4 mm). Tighten lock nut and check clutch pedal free play.

HYDRAULIC SYSTEM BLEEDING

- 1) Connect a flexible tube to slave cylinder bleeder screw, and place opposite end in a container partially filled with brake fluid.
- 2) Pump clutch pedal several times. With pedal depressed, loosen bleeder screw one-third to one-half turn and allow air to bleed out. Tighten bleeder screw.
- 3) Continue operation until air bubbles are no longer seen in fluid being discharged into container. Tighten bleeder screw securely and install cap. Check fluid level in master cylinder reservoir, and check system for leaks.