

TOYOTA CELICA, COROLLA, CORONA, PICKUP, STARLET & SUPRA

DESCRIPTION

Clutch is a dry, single plate, diaphragm spring type which is hydraulically operated by a firewall mounted master cylinder and clutch housing mounted slave cylinder. The slave cylinder used on 4-WD Pickup is adjustable; all others are non-adjustable and clearance is automatically compensated for by internal design of cylinder.

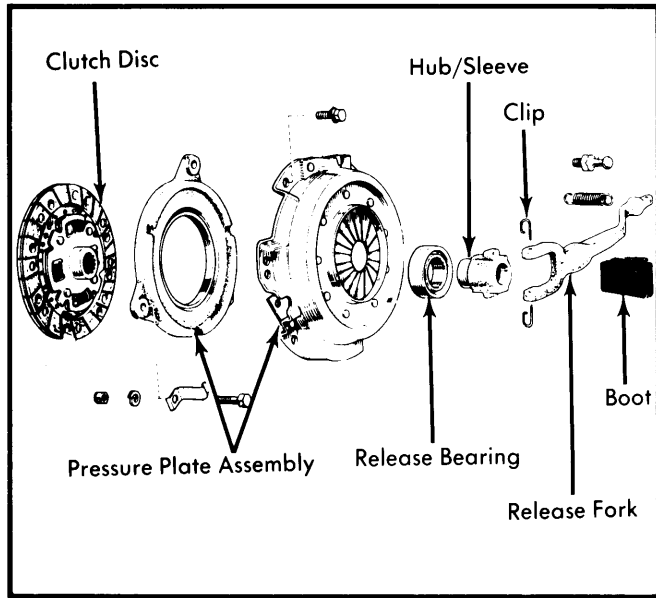

Fig. 1 Exploded View of Typical Clutch Arrangement. Pressure Plate Assembly and Hub/Sleeve Retainer Springs May Vary Between Models.

REMOVAL & INSTALLATION

CLUTCH ASSEMBLY

NOTE — Clutch removal procedures are of a general nature written to cover all Toyota models.

Removal — 1) Disconnect battery cable. Remove air cleaner and drain cooling system, then disconnect top radiator hose. Disconnect accelerator control rod linkage. Remove shift lever boot and shifter assembly. Remove starter.

2) Raise vehicle and support at front and rear with jack stands. If equipped, remove protective cover from under engine.

3) Remove clutch slave cylinder, but only disconnect hydraulic line if necessary. Disconnect exhaust pipe support bracket from mounting and separate exhaust pipe from manifold. Disconnect speedometer cable and electrical leads from transmission.

4) Scribe index marks on drive shaft and coupling for reinstallation reference, then remove drive shaft. Insert suitable plug into extension housing to prevent oil spillage.

5) Support engine with suitable jack, using a wooden block to protect oil pan. Support transmission with transmission jack and remove rear support crossmember. Lower transmission jack slightly and remove transmission-to-engine bolts. Pull transmission to rear; lower and remove from vehicle.

6) Index mark clutch assembly and flywheel for reassembly reference. Loosen bolts securing clutch assembly, alternately and evenly until pressure plate is released. Separate clutch disc and pressure plate.

Installation — To install, reverse removal procedure and note the following: Use a suitable aligning tool to center clutch disc on flywheel. Tighten clutch pressure plate attaching bolts alternately and evenly in a diagonal progression. With transmission installed, adjust clutch.

CLUTCH MASTER CYLINDER

Removal & Installation — Disconnect master cylinder push rod at clutch pedal by removing cotter pin and clevis. Disconnect hydraulic line at cylinder. Remove cylinder attaching nuts and remove cylinder from firewall. To install, reverse removal procedure and adjust pedal height, free play and bleed hydraulic system.

CLUTCH SLAVE CYLINDER

Removal & Installation — Raise and support vehicle on safety stands. Disconnect hydraulic line and clip. Remove slave cylinder attaching nuts and remove slave cylinder. To install, reverse removal procedure and bleed hydraulic system.

CLUTCH RELEASE BEARING

Removal — With transmission removed, check release bearing for freedom of rotation with bearing still installed on hub. To remove, disconnect spring clips from bearing collar and slide bearing off transmission input shaft. Use a press to remove and install bearing on sleeve.

Installation — Slide bearing and collar over transmission input shaft and secure to release lever with new retaining clips. Apply grease to diaphragm spring contact points before installing transmission.

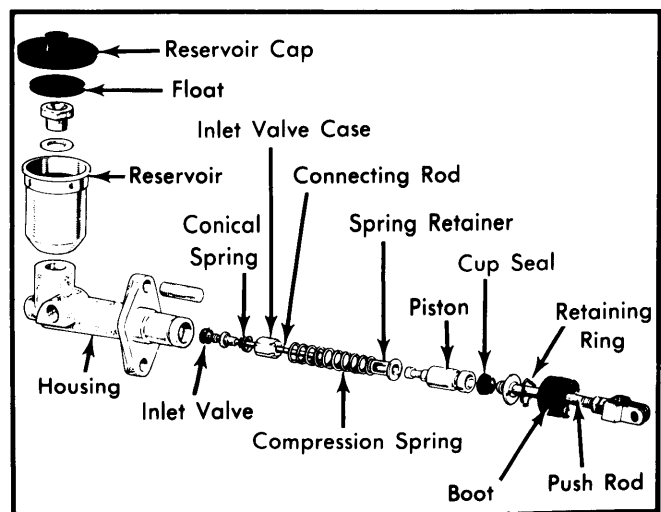

Fig. 2 Exploded View of Clutch Master Cylinder

TOYOTA CELICA, COROLLA, CORONA, PICKUP, STARLET & SUPRA (Cont.)

OVERHAUL

CLUTCH MASTER CYLINDER

Disassembly — With cylinder removed from vehicle, clamp it into a soft jawed vise. Remove reservoir, snap ring and push rod. Pull out piston, cup and remaining internal components. Further disassemble piston by prying up spring retainer and separating retainer from piston.

Cleaning & Inspection — Wash all parts in clean brake fluid and dry with compressed air. Master cylinder bore-to-piston clearance should not exceed .006" (.15 mm). Check compression spring for distortion or weakening and reservoir for damage. Ensure reservoir vent hole is open. Replace defective parts as required.

Reassembly — Dip cylinder cups into clean brake fluid or coat with rubber grease before assembly. Assemble piston components in reverse order of disassembly. Install piston assembly, push rod and reservoir into master cylinder.

CLUTCH SLAVE CYLINDER

Disassembly — Remove rubber boot and push rod. Remove piston assembly and spring from bore. If necessary, remove bleeder screw.

Cleaning & Inspection — Wash all parts in clean brake fluid and dry with compressed air. Slave cylinder bore-to-piston clearance should not exceed .006" (.15 mm). Replace defective parts. Replace piston cups during overhaul.

Reassembly — Install piston cups on piston and coat with brake grease. Install spring and piston assembly into cylinder bore and install rubber boot (protruded part down). Install push rod and bleeder screw.

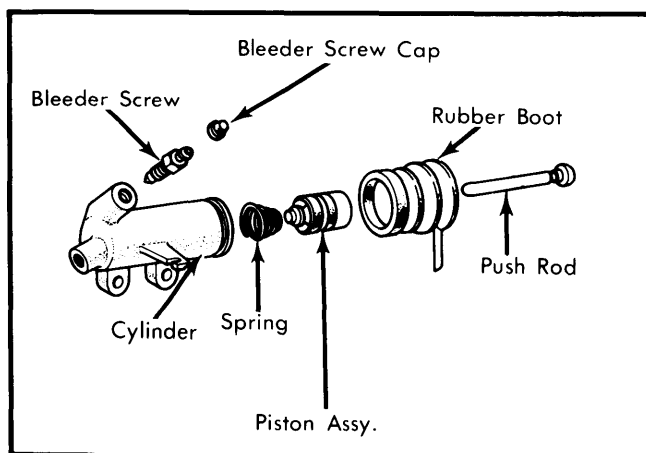

Fig. 3 Exploded View of Slave Cylinder (External Design Differs Among Models)

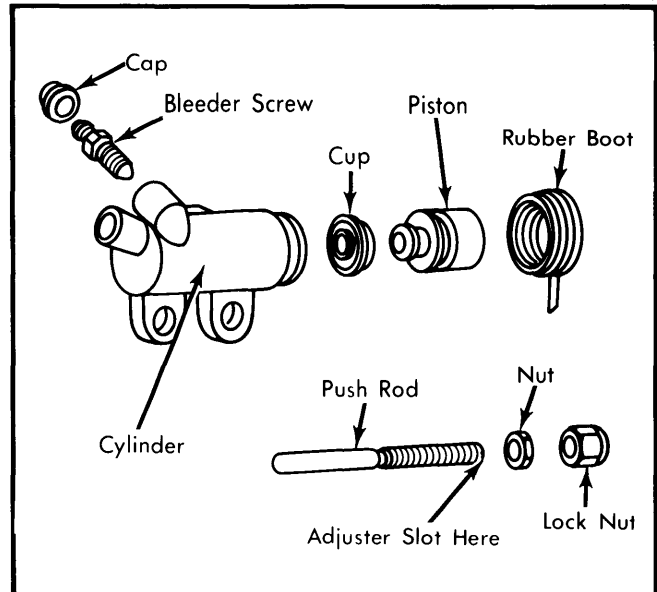

Fig. 4 Exploded View of Slave Cylinder (4-WD Pickup Models Only)

ADJUSTMENT

PEDAL HEIGHT

Adjust pedal stop bolt at top of pedal assembly until specified pedal height is obtained. Height is measured from floor mat to top of pedal pad.

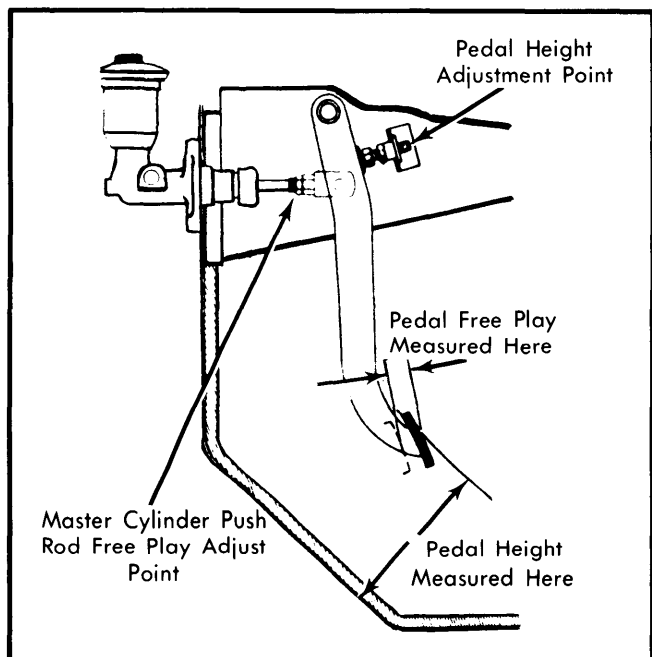

Fig. 5 Pedal Height and Free Play Measuring Points

TOYOTA CELICA, COROLLA, CORONA, PICKUP, STARLET & SUPRA (Cont.)

Pedal Height Specifications

Application	Height In. (mm)
Celica & Supra	6.3-6.7 (159.5-169.5)
Corolla	6.9-7.3 (175-185)
Corona	6.5-6.9 (166-176)
Pickup	6.0-6.4 (152-162)
Starlet	7.0 (178)

Pedal Free Play

Application	In. (mm)
Celica, Corolla & Corona5-.9 (13-23)
2-WD Pickup & Supra2-.6 (5-15)
4-WD Pickup	1.0-1.8 (25-45)
Starlet8-1.4 (20-36)

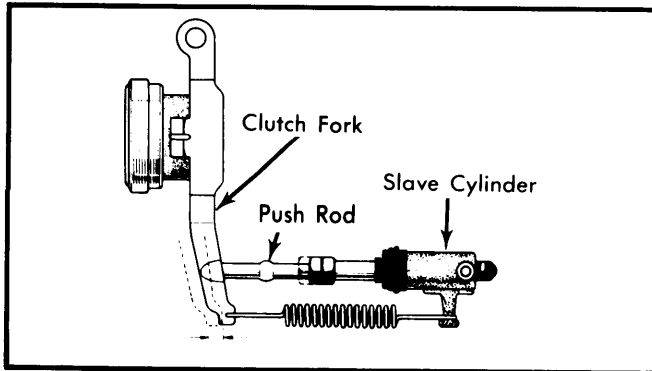

Fig. 6 Clutch Fork Free Play Adjustment (4-WD Pickup Models Only)

PEDAL FREE PLAY

Except 4-WD Pickup – To adjust free play (measured at pedal pad), loosen lock nut on master cylinder push rod and turn push rod in or out until free play is within specifications. Tighten lock nut.

4-WD Pickup – Prior to adjusting pedal free play as described for other models, adjust clutch fork free play. To adjust fork free play, loosen lock nut on slave cylinder push rod and screw push rod in or out to obtain .08-.12" (2-3 mm) free play at clutch fork. Tighten lock nut and adjust pedal free play to 1.0-1.8" (25-45 mm).

HYDRAULIC SYSTEM BLEEDING

- 1) Raise and support vehicle on safety stands. Check master cylinder reservoir often during bleeding operation; add fluid as required. Remove slave cylinder bleeder screw cap and connect flexible hose to bleeder and immerse opposite end of tube in jar partially filled with brake fluid.
- 2) Pump clutch pedal several times. With pedal depressed, loosen screw 1/2 turn, exhaust air and close before pressure is depleted. Repeat operation until no air bubbles are seen in discharged fluid. Close bleeder screw on down stroke of pedal. Check system for leaks and fill master cylinder reservoir.

TIGHTENING SPECIFICATIONS

Application	Ft. Lbs. (N·m)
Clutch Housing-to-Engine	
Supra	22-23 (30-31)
All Others	36-58 (49-79)
Pressure Plate-to-Flywheel	11-15 (15-20)