

ISUZU P'UP & LUV

Pickup

DESCRIPTION

Clutch assembly is a single dry disc type using a diaphragm spring pressure plate with a pre-lubricated release bearing. Clutch release lever is cable actuated. Cable is hooked to release lever and clutch pedal.

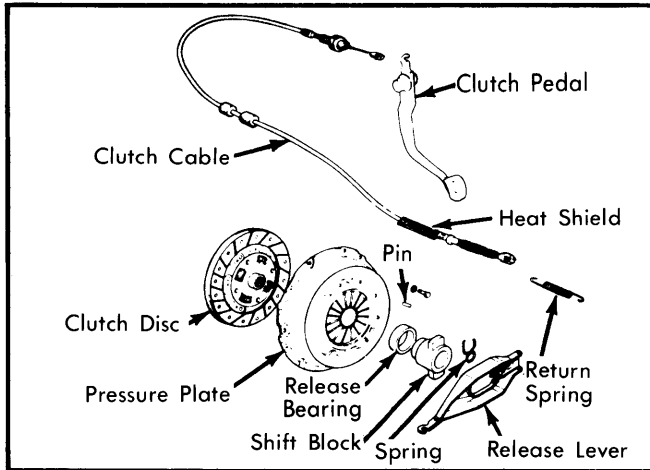

Fig. 1 Exploded View of P'UP & LUV Clutch Assembly

REMOVAL & INSTALLATION

CLUTCH ASSEMBLY

Removal (2WD) – 1) Disconnect negative battery cable. Slide gearshift lever boot up on lever, remove gearshift lever attaching bolts and remove lever assembly. Remove starter attaching bolts and lay starter aside.

2) Raise vehicle on hoist and disconnect exhaust pipe hanger at transmission. Disconnect speedometer cable at transmission and disconnect ground strap. Place a pan in position to catch oil and remove propeller shaft.

3) Remove 2 lower flywheel inspection cover mounting bolts. Remove 2 bolts mounting frame bracket to rear mount. Using a jack, slightly raise transmission and remove 4 crossmember-to-frame bolts. Remove 2 bolts mounting transmission extension housing.

4) Lower engine and transmission assembly and support rear of engine. Disconnect electrical leads at transmission. Remove transmission-to-engine attaching bolts and remove transmission.

5) Mark pressure plate and flywheel for reassembly reference. Loosen pressure plate attaching bolts 1 turn at a time until spring pressure is released. Support clutch assembly with clutch aligning tool (J-24547 or equivalent), remove bolts, and remove clutch assembly.

Removal (4WD) – 1) Disconnect negative battery cable. Drain transmission. Slide transmission and transfer case shift lever boots upward on levers. Remove gearshift lever attaching bolts. Remove spring from transfer case shift lever and remove both levers.

2) Remove starter attaching bolts and lay starter aside. Raise vehicle on hoist and disconnect exhaust pipe from manifold. Remove exhaust pipe hanger from transmission. Disconnect speedometer cable and ground cable at transmission.

3) Disconnect propeller shaft at differential and remove from vehicle. Disconnect front propeller shaft at both ends. Remove

return spring at clutch fork. Disconnect clutch cable from clutch fork and pull forward through stiffener bracket.

4) Remove 2 lower bolts mounting flywheel guard. Remove 3 frame bracket-to-transmission rear mount bolts and nuts. Raise engine slightly and remove rear mounting bolts from transfer case. Remove side case attaching bolts and remove case.

5) Remove stud bolt from transfer case. Lower engine and transmission and support rear of engine. Disconnect electrical connectors from transmission. Remove shift cover and gasket from top of transfer case. Remove transmission-to-engine bolts and remove transmission.

NOTE – When removing transmission, turn side case fitting face of transmission case down and pull transmission back to clear clutch shaft. Tip transmission downward and remove transmission.

6) Mark pressure plate and flywheel for reassembly reference. Loosen pressure plate attaching bolts 1 turn at a time until pressure is relieved. Support clutch assembly with a clutch aligning tool (J-24547 or equivalent) and remove clutch assembly.

Installation (All Models) – Apply a thin coat of Lubriplate (or equivalent) to clutch disc splines. Install clutch assembly to flywheel, matching alignment marks made during disassembly. Use clutch alignment tool (J-24547 or equivalent) to center clutch. Install and tighten attaching bolts. To complete installation, reverse removal procedure.

RELEASE BEARING, SHIFT BLOCK & RELEASE LEVER

Removal – Remove release lever from transmission case. Disengage release bearing to lever retaining springs. Slide out release bearing with shift block. Remove release lever from transmission ball stud.

Inspection – 1) Check release bearing for noise or lubricant loss by spinning bearing. Replace bearing if either condition exists.

2) Inspect release lever ball socket and lever contact surface for signs of excessive wear. Also, check retaining spring for signs of weakening. Make sure spring will hold lever tightly to ball stud.

Installation – Install release lever ball stud in cover. Lubricate shift block inner groove, ball seat and release bearing contact surface with graphite grease. Install release lever and bearing assembly. Attach release bearing spring to lever and spring clip to ball stud. Ensure release lever fully engages ball stud and that release bearing moves smoothly. Install fork boot in case.

PILOT BEARING

Check pilot bearing for seizing, sticking, abnormal noise or wear. If replacement is required, use a suitable tool (J-23907) to remove bearing.

CLUTCH CABLE

Removal – 1) Loosen clutch cable lock nut and adjusting nut. Free cable from various routing clips in engine compartment. Working under vehicle, disengage return spring from release lever.

ISUZU P'UP & LUV (Cont.)

2) Disconnect cable from bracket and pull cable forward through bracket. Separate cable from clutch pedal and pull cable into engine compartment with damper rubber.

Installation — To install, reverse removal procedures and note the following: Ensure cable is not bent sharply or kinked. Keep lock and adjustment nuts loosened when installing.

ADJUSTMENT

CLUTCH CABLE

Pull cable into engine compartment. Rotate adjuster nut until washer damper assembly is brought back into contact with firewall. Work clutch pedal several times. Pull cable out again and fully tighten nut. Back adjusting nut off until there is about .196" (5 mm) between adjusting nut and boot. See Fig. 2. Tighten lock nut.

CLUTCH PEDAL HEIGHT

With clutch switch on pedal bracket, adjust pedal height to 6.40-8.85" (164-174 mm).

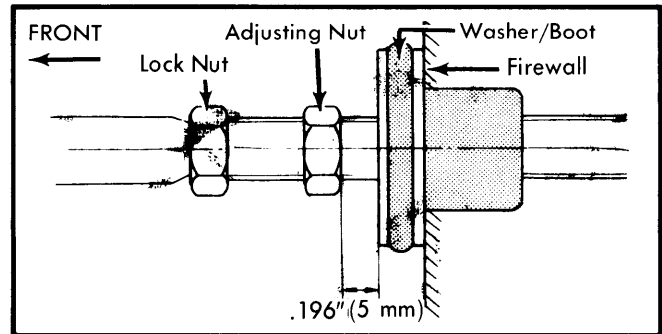

Fig. 2 Clutch Cable Adjustment Gap

TIGHTENING SPECIFICATIONS

Application	Ft. Lbs. (N•m)
Pressure Plate-to-Flywheel	13 (18)
Ball Stud-to-Front Cover	30 (41)