

COURIER

Pickup

DESCRIPTION

Clutch is of single dry disk type. Clutch assembly consists of clutch disc, clutch cover and pressure plate assembly, and clutch release mechanism. Clutch housing also acts as the transmission input shaft bearing retainer, and contains the input shaft bearing oil seal and a selective fit thrust washer for controlling input shaft end play. Clutch release mechanism is hydraulic, consisting of a firewall mounted master cylinder and a slave cylinder mounted on flywheel housing. To control clutch engagement, a one-way valve is mounted on clutch master cylinder to control the flow of return fluid when pressure on clutch is released.

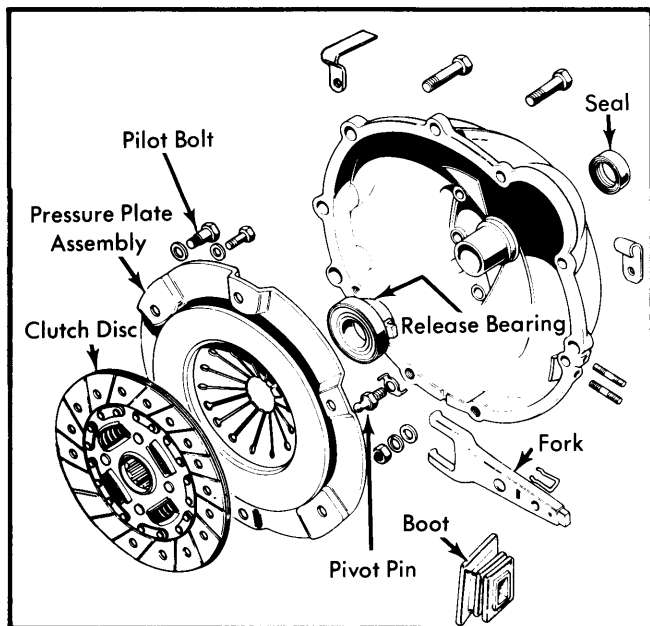

Fig. 1 Exploded View of Clutch Assembly with Detail of Internal Components

REMOVAL & INSTALLATION

CLUTCH ASSEMBLY

Removal — 1) Disconnect negative battery cable. Place transmission in neutral. On 5-speed transmission, remove boot retaining screws. Remove bolts attaching the retainer cover to the gearshift lever retainer and pull gearshift lever, shim and bushing up and away from retainer.

2) On 4-speed transmission, lift boot and remove screws, lock washer and flat washers attaching gearshift tower to the extension housing. Remove shift lever, tower and gasket as an assembly along with 2 shift lever boots.

3) On all models, cover opening and raise vehicle. Disconnect drive shaft and drive shaft center bearing supporting nuts and washers (if equipped). Disconnect drive shaft from transmission and install a plug in extension housing to prevent fluid leakage.

4) Disconnect exhaust pipe brackets from transmission case and clutch housing. Remove exhaust pipe and catalytic assembly. Disconnect clutch release lever return spring. Remove clutch release cylinder and secure it to the side. Remove speedometer cable from extension housing.

5) Disconnect wiring from transmission and starter. Support engine with a jack and remove starter. Support transmission and remove

bolts, lock washers and flat washers attaching transmission to the engine rear plate. Remove crossmember attaching nuts and bolts at transmission and frame side rails and remove crossmember.

6) Lower engine jack and remove transmission by sliding rearward and downward. Mark location of 2 pilot bolt holes on flywheel and pressure plate. Remove clutch attaching bolts and clutch assembly.

NOTE — Transmissions have aluminum cases. Install flat washer between case and attaching bolt or nut.

Installation — To install, reverse removal procedure and note: Align clutch disc and flywheel with centering tool. Install pressure plate and bolts finger tight, then tighten bolts a few turns at a time in a criss-cross pattern. Bleed hydraulic system and adjust clutch pedal free play.

RELEASE LEVER & BEARING

Removal — With transmission removed, disconnect release collar spring and slide out release lever, boot and bearing. Inspect all parts for wear or damage.

Installation — To install, apply lubricant to input shaft bearing retainer of clutch housing and pivot bolt. Seat release lever on pivot. Apply lubricant to bearing contact surface of lever. Install release bearing and hook release collar spring. Lubricate face of release bearing. Lever and bearing must operate freely.

CLUTCH MASTER CYLINDER

Removal — Disconnect and plug hydraulic lines. Remove master cylinder attaching nuts. Remove master cylinder.

Installation — To install, start pedal push rod into cylinder, then position cylinder against firewall. Install and tighten attaching nuts. Connect hydraulic line. Bleed hydraulic system and check pedal free play.

CLUTCH SLAVE CYLINDER

Removal — Disconnect hydraulic fluid inlet line at slave cylinder. Unhook release lever from push rod. Remove nuts attaching slave cylinder to clutch housing and remove cylinder.

Installation — Locate cylinder on studs in housing. Tighten nuts. Connect fluid inlet line. Fill master cylinder and bleed hydraulic system. Hook clutch release lever into slave cylinder push rod.

OVERHAUL

CLUTCH MASTER CYLINDER

1) Clean outside of cylinder, drain fluid and remove dust boot. Using a screwdriver, remove piston stop ring and washer. Remove piston, piston cup and return spring from cylinder.

2) Wash all parts in clean alcohol or brake fluid. Check all rubber components and replace if damaged, worn, softened or swollen. Check cylinder bore for wear or damage, and check clearance between cylinder bore and piston. Replace cylinder or piston if clearance is more than .004" (.102 mm).

3) To assemble, dip piston and cups in clean brake fluid and reverse disassembly procedure. When assembled, fill reservoir with fluid and operate piston with a screwdriver until fluid is ejected at outlet fitting.

Clutches

COURIER (Cont.)

CLUTCH MASTER CYLINDER ONE-WAY VALVE

Disassembly — Remove cap from side of clutch master cylinder. See Fig. 2. Slide out washer, one-way valve and spring.

Reassembly — Position spring along with one-way valve into cylinder housing. Fit cap and washer.

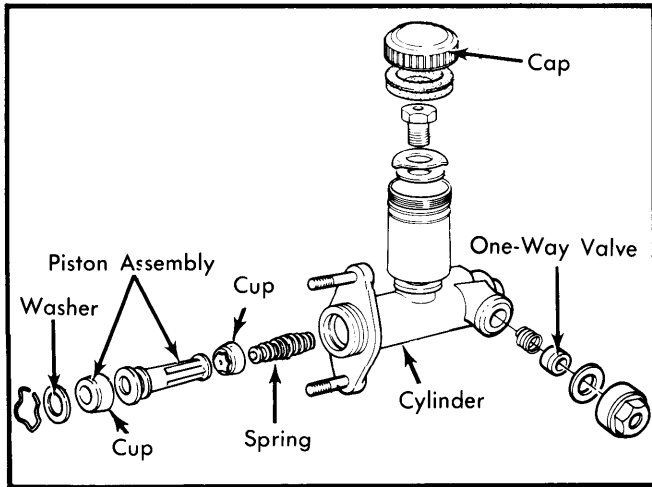

Fig. 2 Exploded View of Clutch Master Cylinder Assembly and One-Way Valve

SLAVE CYLINDER

Disassembly — 1) Clean outside of housing. Remove dust boot and clutch release rod.

2) Remove piston assembly and return spring. Remove bleeder screw cap, bleeder screw and steel ball.

Inspection — Check cylinder bore and piston for roughness, wear or scoring. Clearance between cylinder bore and piston should be .004" (.102 mm). Replace piston or cylinder if specification is exceeded.

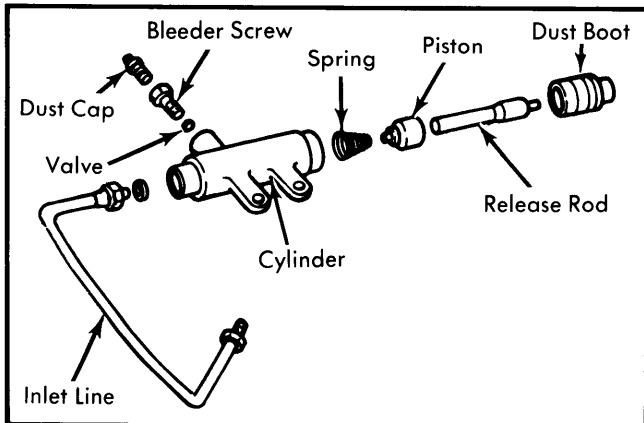

Fig. 3 Exploded View of Courier Slave Cylinder

Reassembly — 1) Lightly coat piston and cups with brake fluid. Fit cups to piston. Install piston into cylinder.

2) Install release rod and boot. Place steel ball into cylinder. Screw in bleeder and fit dust cap.

ADJUSTMENTS

CLUTCH PEDAL

Pedal free play is adjusted by loosening lock nut on push rod and rotating rod until .79-1.18" (20-30 mm) free travel is obtained at pedal pad. See Fig. 4. Tighten lock nut when adjustment is completed.

NOTE — Free travel includes travel in master cylinder.

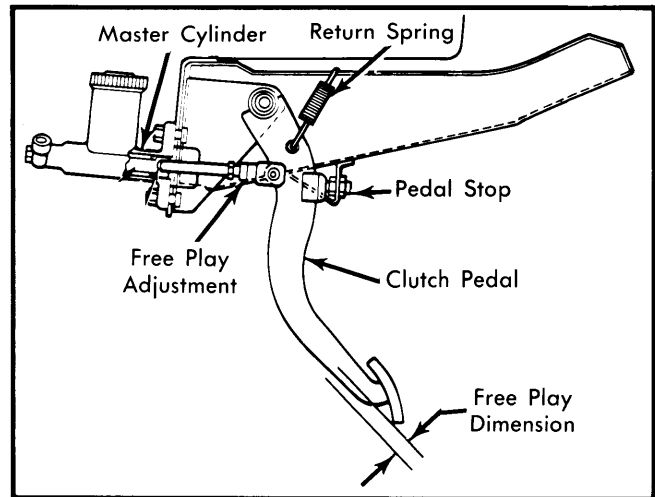

Fig. 4 Clutch Pedal Adjustment Procedure

HYDRAULIC SYSTEM BLEEDING

Remove rubber cap from bleeder valve and attach a bleeder tube and fixture to bleeder screw. Place other end of tube in a glass jar of brake fluid and open bleeder screw. Depress clutch pedal and allow to return slowly. Continue pumping action until air bubbles cease to appear in glass jar, then close bleeder screw. Install rubber cap on bleeder screw and fill master cylinder.

NOTE — During bleeding, master cylinder must be kept 3/4 full of brake fluid.

TIGHTENING SPECIFICATIONS

Application	Ft. Lbs. (N•m)
Clutch Housing-to-Engine	
2000 cc Engine	34-45 (46-61)
2300 cc Engine	28-40 (38-54)
Pressure Plate-to-Flywheel	14-20 (19-27)
Slave Cylinder-to-Clutch Housing	12-17 (16-23)
Pivot Pin	23-34 (31-46)
Master Cylinder Attaching Bolts	14-18 (19-24)