

CHRYSLER CORP. IMPORTS — REAR-WHEEL-DRIVE MODELS

Arrow Pickup
Challenger
Ram-50 Pickup
Sapporo

DESCRIPTION

Clutch is a diaphragm spring, single disc type. Operation is controlled mechanically by a cable. Clutch release bearing is sealed and permanently lubricated.

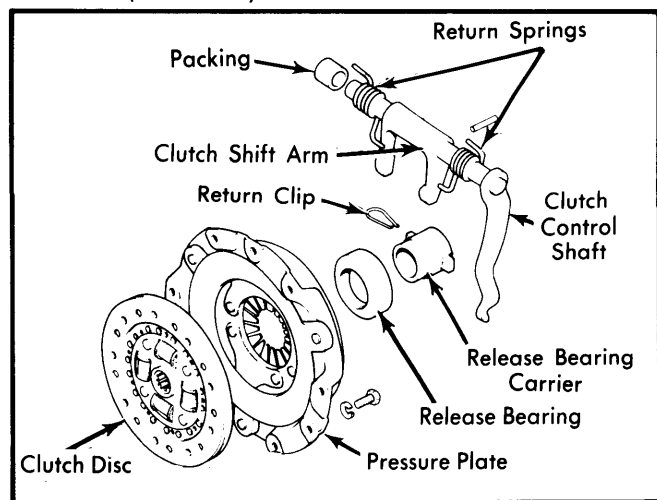

Fig. 1 Exploded View of Clutch Assembly

REMOVAL & INSTALLATION

NOTE — Procedure is general for all models. Some steps do not apply to all models.

CLUTCH ASSEMBLY

Removal — 1) Disconnect battery ground cable. Remove air cleaner assembly. Remove starter. Insert rag between rocker cover and firewall.

2) From inside vehicle, remove console box (if equipped); remove back bone carpet. Remove dust cover retaining plate. Remove extension housing attaching bolts and control lever assembly.

NOTE — Lever should be in 2nd gear on 4-speed transmissions and in 1st gear on 5-speed transmissions.

3) Raise and support vehicle on jack stands; drain transmission fluid. Disconnect propeller shaft-to-differential pinion flange bolts. Remove center bearing (if equipped) and remove propeller shaft from transmission. Disconnect speedometer cable and backup light connector from transmission. Disconnect exhaust pipe from exhaust manifold and clutch cable from transmission. Support rear of engine on safety stands. With a service jack placed under transmission, remove rear engine support bracket.

NOTE — Place jack under transmission oil pan, with the support area as wide as possible.

4) Remove bell housing cover and remaining transmission-to-bell housing mounting bolts. Pull transmission assembly rearward from engine and remove from vehicle.

NOTE — Use care not to twist front end of main drive gear.

5) Insert clutch centering tool (MD998017) into clutch center hole to prevent dropping clutch disc. Alternately loosen clutch attaching bolts diagonally and evenly and remove clutch cover assembly. Separate pressure plate and clutch disc.

Installation — To install, reverse removal procedure and note the following: Use clutch centering tool (MD998017) to center clutch disc on flywheel. Apply lubricant to clutch disc splines and input shaft splines.

NOTE — Clutch disc must be installed with stamped manufacturer's mark on pressure plate side. Also, be sure to keep disc facing, flywheel and pressure plate clean, dry and free of grease and oil.

CLUTCH CABLE

Removal — Loosen cable adjusting wheel inside engine compartment, then loosen clutch pedal lock nut. Remove clutch cable from control lever, then from clutch pedal lever and remove from vehicle.

Installation — To install clutch cable, reverse the removal procedure and note following: Apply engine oil as necessary to install cable. Some models are equipped with insulating pads. Fit pads where cable routes near intake manifold and at rear side of engine mount.

CLUTCH RELEASE BEARING & SHIFT ARM

Removal — With transmission removed, remove return clip on transmission side, then slide off release bearing carrier and release bearing. Using a $\frac{3}{16}$ " punch, remove shift arm spring pin and control lever assembly, then remove the shift arm and return springs. See Fig. 2.

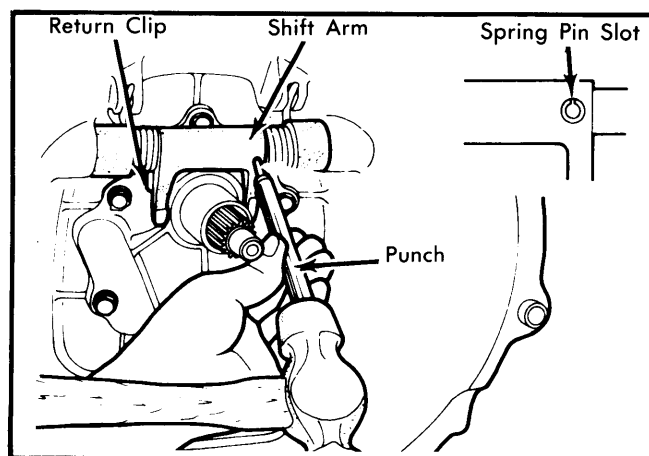

Fig. 2 Removing and Installing Shift Arm Spring Pins

Installation — 1) Insert lever and shaft into transmission case from left side. Place shift arm, felt packings and return springs on shaft assembly.

2) Apply grease to inside of bushing and oil seal lips. Apply engine oil to felt packings. Align shift arm pin holes and control shaft pin holes. Drive spring pins into position. See Fig. 2.

NOTE — Spring pin slot direction must be at right angle to control shaft centerline.

Clutches

CHRYSLER CORP. IMPORTS – REAR-WHEEL-DRIVE MODELS (Cont.)

ADJUSTMENTS

PEDAL HEIGHT ADJUSTMENT

Rotate clutch pedal adjusting bolt (at top of clutch pedal) so that pedal height is as indicated in table. Pedal height is measured between floor board and top of clutch pedal pad.

Clutch Pedal Height and Travel		
Application	Height In. (mm)	Travel In. (mm)
Pickup Trucks		
2000 cc Engine	6.5 (166)	5.5 (140)
2600 cc Engine	6.9 (176)	5.9 (150)
All Others	7.1 (180)	5.8 (148)

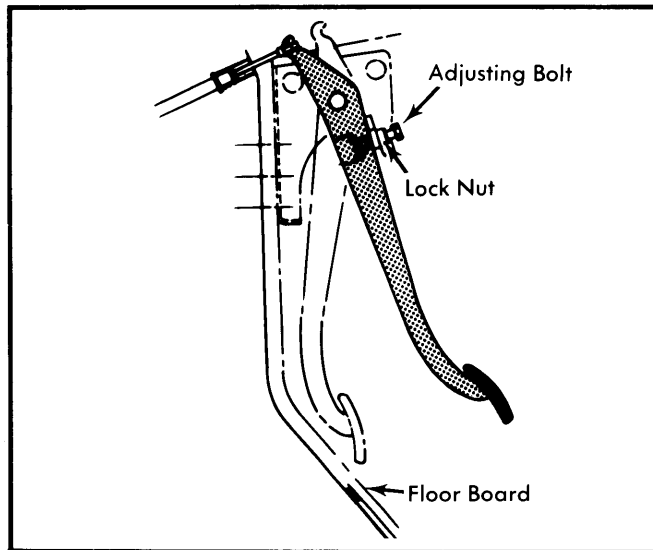

Fig. 3 Clutch Pedal Adjustment Procedure

CLUTCH CABLE

Pull clutch cable housing toward engine compartment. Rotate cable adjusting nut until .12-.16" (3-4 mm) clearance is obtained between adjusting nut and holder. Clutch pedal free play should be .8-1.4" (20-35 mm) for pickups and .6-.8" (15-20 mm) for all other models.

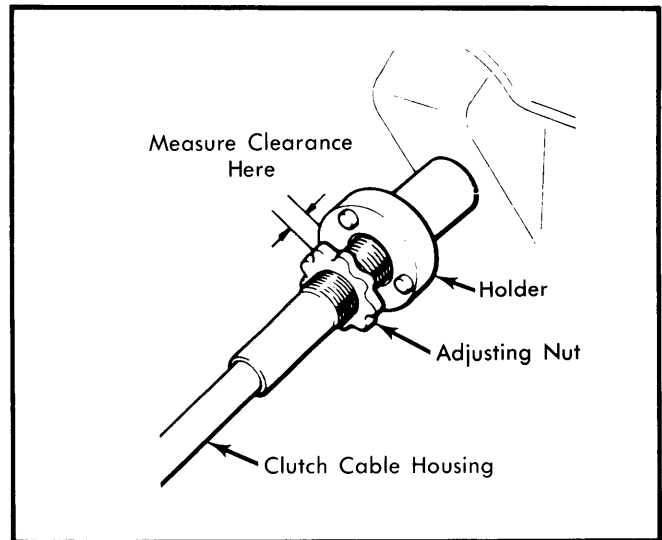

Fig. 4 Clutch Cable Adjustment Point

TIGHTENING SPECIFICATIONS

Application	Ft. Lbs. (N·m)
Transmission-to-Engine Flange Bolts	32-39 (43-53)
Starter Bolts	16-23 (22-31)