

## AUDI 4000

### DESCRIPTION

Clutch is single plate dry disc type, using a diaphragm type pressure plate and a pre-lubricated clutch release bearing. Clutch is cable actuated.

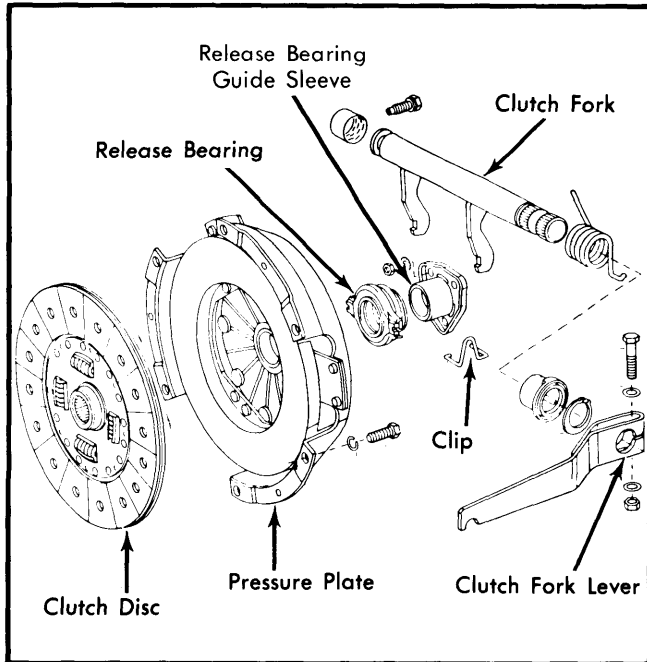

Fig. 1 Exploded View of Clutch Assembly

### REMOVAL & INSTALLATION

#### CLUTCH ASSEMBLY

**Removal** — 1) Disconnect negative battery cable. Disconnect exhaust header pipe at manifold and bracket on transmission. Remove upper transmission-to-engine bolts and engine support bolts. Disconnect backup light wiring and remove air cleaner.

**NOTE** — On models equipped with a 5 cylinder engine and 5 speed transmission, the engine must be supported from above while removing and installing transmission.

2) Remove bolt mounting shift assembly coupling to rear of transmission shifting shaft and separate assemblies. Unhook clutch cable at release lever. Disconnect speedometer.

3) Disconnect axle drive shafts at inner drive flanges. Remove starter. Take out front clutch housing cover plate. Remove remaining transmission-to-engine bolts. On some models, removal of certain steering brackets is necessary to remove transmission,

4) Support transmission with suitable jack. Remove transmission rear mounts and brackets. Remove front support bolts. Pry transmission away from engine and slide it out of vehicle.

5) Install holding tool (10-201) to flywheel and index (mark) pressure plate and flywheel. Loosen pressure plate bolts 1/4 turn at a time in a diagonal pattern. Slide pressure plate off flywheel dowels and separate clutch disc.

**Installation** — To install, reverse removal procedure and note: Use clutch alignment tool to fit pressure plate and clutch. Make sure alignment marks are observed.

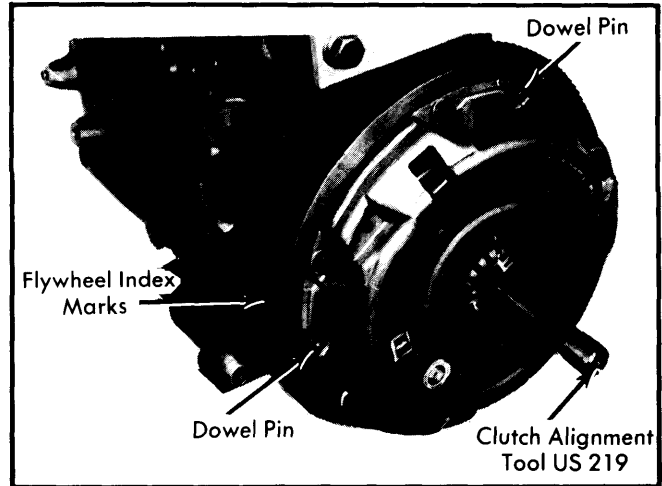

Fig. 2 Aligning Clutch Assembly Reference Marks for Reinstallation

#### CLUTCH RELEASE BEARING

1) With transmission separated from engine, remove spring clips securing release bearing to clutch fork. Bearing is pre-lubricated; do not wash in any cleaning solution.

2) Rotate bearing and check for roughness or noise, replace as necessary. Apply Molykote paste to bearing contact points on clutch fork. To install, reverse removal procedure.

#### PILOT BEARING

Lock flywheel to prevent rotation. Install suitable remover (10-202) and remove pilot bearing. Install bearing with suitable installer (VW207C) and seat bearing until distance from flywheel recess to bushing edge is 1/16" (1.5 mm). Lubricate bearing.

### ADJUSTMENT

#### CLUTCH PEDAL FREE PLAY

Adjust clutch pedal free play by loosening and adjusting both counternuts at clutch cable. Pedal will have .59" (15 mm) free play when properly adjusted. On some models, counternuts are replaced by spring clips.

### TIGHTENING SPECIFICATIONS

Application	Ft. Lbs. (N·m)
Clutch Assembly-to-Flywheel Bolts .....	18 (25)
Transmission-to-Engine Bolts .....	40 (55)