

4-CYLINDER DIESEL & TURBO DIESEL

ENGINE CODING

ENGINE IDENTIFICATION

Engine identification number is stamped on front left side of engine block just below cylinder head. Engine identification number corresponds with Vehicle Identification Number, and runs from number 1340000 upward.

Engine Identification	
Application	Code
504 & 505 Diesel	XD2C
505 & 604 Turbo Diesel	XD2S

ENGINE & CYLINDER HEAD

ENGINE

NOTE — Specific engine removal and installation procedures were not available for 504 diesel and 604 Turbo diesel engines. Procedures should be similar to normally aspirated engines for Turbo. Disconnect any additional components necessary for removal.

Removal — 1) Drain cooling system. Remove battery, battery tray, radiator expansion tank, air filter and intake pipe on vacuum pump. Remove upper and lower radiator hoses and mountings. Disconnect power steering hoses from pump and transmission cooler lines at radiator and suspend high enough to prevent drainage.

2) Remove radiator. Remove starter and clutch housing sealing plates. Remove fan and belt tensioners. On air conditioned models, protect condenser with plywood. Remove air conditioner compressor and hang along inner fender with hoses attached. Route refrigerant hoses to back of engine.

3) On all models, remove sound proofing panel clips on the cowl panel and remove degassing tank bracket. Remove mounting bolts on front header pipe to manifold, intermediate exhaust muffler and lower the compressor cut-out switch (if equipped). Lower front crossmember after having removed mounting bolts. Suspend crossmember with two 12 X 150 bolts approximately 2 $\frac{3}{4}$ -4" (70-100 mm) long (P.N. 6902.77).

4) On automatic transmission models, remove the torque converter bolts (accessible through starter motor opening). Move torque converter back from flywheel. Loosen 3 engine-to-clutch housing bolts slightly using a hex socket (8.0208). Remove the top converter bolt.

5) On all models, remove the 4 mounting bolts of the engine mounts on the main crossmember. Install lifting hooks (8.0102X) and lift until transmission touches tunnel. Install engine support bracket (8.0125). Disconnect the power steering line leading to the distribution valve.

6) Remove the 2 lower engine-to-transmission mounting bolts, clear engine and lift, being careful not to pull on refrigerant lines. On automatic transmission models, ensure torque converter is fully disengaged, and install torque converter retaining clamp.

Installation — On manual transmission models, coat main-shaft splines with Molykote 321. On automatic transmission models, coat converter nipple with Calysol F3015 grease. To complete installation, reverse removal procedures.

CYLINDER HEAD

CAUTION — Cylinder head bolts must not be loosened while engine is warm.

Removal — 1) Drain cooling system. Disconnect and remove battery. Disconnect exhaust pipe from manifold, vacuum pump, overflow reservoir, electrical connections and harness securing clips from engine. Disconnect heater hose, rocker oil feed pipe at cylinder head, and remove upper power steering pump bracket mounting bolt.

2) Remove water pump bolt, valve cover, rocker shaft assembly and push rods. Gradually loosen cylinder head bolts in sequence shown in Fig. 1. Remove cylinder head using levers (0.0149).

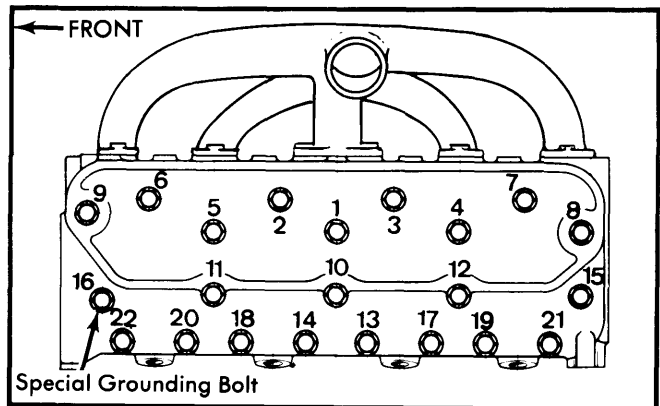

Fig. 1 Cylinder Head Bolt Tightening Sequence

Installation — 1) Run an 11 X 150 tap through bolt holes to clean threads and clean all foreign material and oil from threads. Brush clean bolt threads. Use new domed washers on non-Turbo engines with dome installed up (on Turbo engines, use flat washers). Carefully clean mating surfaces of cylinder head and block.

2) Check amount of piston protrusion to determine correct head gasket thickness. Measure the amount of piston protrusion with a dial indicator and tool (8.011 P). Select the maximum amount of protrusion (all 4 cylinders). If protrusion is greater to or equal to .030" (.79 mm) for Turbo, or more than .033" (.84 mm) for non-Turbo engines, gasket thickness needed is .067" (1.7 mm).

3) Reference mark for this gasket is 3 notches. If protrusion is less than .030" (.79 mm) for Turbo, or less than .033" (.84 mm) for non-Turbo engines, gasket thickness required is .067" (1.58 mm). Reference mark for this gasket is 2 notches.

4) Install cylinder head guides (8.0114) in bolt holes 15 and 16. See Fig. 1. Install the correct thickness gasket dry. Place cylinder head over guides and install remaining bolts, noting

4-CYLINDER DIESEL & TURBO DIESEL (Cont.)

that 8 short bolts are installed on injector side, 7 medium length bolts are installed on manifold side and 6 long bolts are installed in center.

5) Bolt threads and contact faces should be lightly lubricated with engine oil on non-Turbo engines, and coated with Molykote 6 Rapid (PN 9730.08) on Turbo engines. Remove guides and install remaining bolts. Special ground bolt is installed in No. 16 position.

6) Tighten cylinder head bolts in 1st step to 22 ft. lbs. (30 N•m) in sequence shown in Fig. 1. In 2nd step, tighten in sequence Turbo bolts to 51 ft. lbs. (69 N•m), non-Turbo to 47 ft. lbs. (64 N•m). Third and final step consists of loosening each bolt (1 at a time in sequence) 1/4 turn and retightening.

7) Install injector holders with new seals, injector shields and washers. Install push rods to original positions and install rocker arm assembly. See Rocker Arm Assembly in this article. Adjust valves as outlined in Valve Clearance Adjustment.

NOTE — Cylinder head bolts must be retightened after 30-60 miles and again after 1000-1500 miles. Engine must be allowed to cool 6 hours before retightening bolts. To retighten, loosen bolt 1/4 turn (1 bolt at a time) and tighten to final torque following sequence shown in Fig. 1.

VALVES

VALVE ARRANGEMENT

I-E-E-I-I-E-E-I (Front to Rear).

NOTE — Cylinders and valves are numbered with number one at flywheel end.

VALVE DEPTH

After cylinder head has been resurfaced or valve seats reground or replaced, depth of valve face beneath cylinder head must be checked. Measure depth with a dial indicator. If less than specification, replace valves and/or valve seats. If more than specification, regrind valve seats.

Valve Face Depth	
Application	Depth In. (mm)
Non-Turbo	.033-.047 (.85-1.20)
Turbo	
Intake	.041-.047 (2.05-1.40)
Exhaust	.033-.047 (.85-1.20)

ROCKER ARM ASSEMBLY

1) To remove rocker arm assembly, remove rocker arm cover and remove rocker shaft support bolts. Lift rocker arm assembly noting oil line union sealing washer.

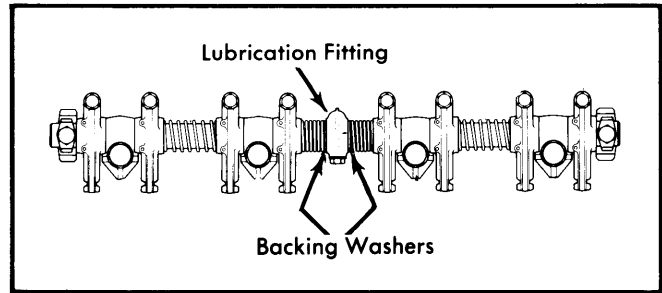

Fig. 2 Assembled View of Rocker Arm Assembly with Oil Holes Detailed

2) To disassemble rocker arm assembly, remove end shaft supports and remove rocker arms, supports, springs and washers. Remove locating screw on lubrication fitting, then remove shaft.

3) Check shaft diameter at areas where rocker arms contact shaft. Minimum diameter of shaft is .746" (18.95 mm). Replace shaft and/or rocker arms if excessive wear or scoring is evident.

4) To assemble rocker arm assembly, slide rocker shaft into lubrication fitting noting that oil holes in shaft are on same side as screw hole in fitting. Line up screw hole in shaft with threaded hole in fitting and install locating screw and copper washer.

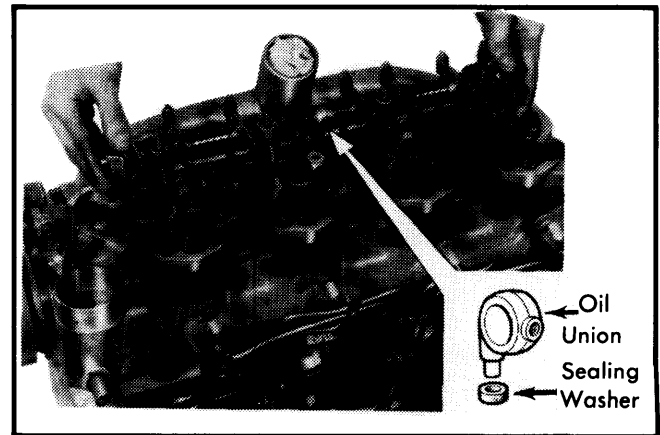

Fig. 3 Installing Rocker Arm Assembly to Cylinder Head

5) Lubricate rocker shaft and install washers, springs, rocker arms and supports. Install push rods and install rocker shaft assembly to cylinder head. Install .004" (.10 mm) shims between each of the end rocker shaft bearing blocks and on Turbo, between No. 1 & 4 intake rockers.

6) Install new oil union seal washer. Tighten intermediate bearing blocks (nuts), then tighten end supports (bolts). Remove shims and check for free movement of the 2 end rockers. There should be .004" (.10 mm) play at the 2 end rocker arms.

VALVE CLEARANCE ADJUSTMENT

NOTE — Engine must be allowed to cool at least six hours before adjusting valves.

4-CYLINDER DIESEL & TURBO DIESEL (Cont.)

Rotate engine until exhaust valve number one is fully opened, then adjust intake valve number three and exhaust number four. Rotate engine one half turn until next number valve is fully opened and adjust corresponding valves. See table. Continue until all valves have been adjusted.

Valve Adjusting Sequence	
Valve Open	Adjust Valves
E1	I3 & E4
E3	I4 & E2
E4	I2 & E1
E2	I1 & E3

Valve Clearance Adjustment		
Application	Intake In. (mm)	Exhaust In. (mm)
Turbo006 (.15)	.010 (.25)
Non-Turbo ..	.010-.012 (.250-.255)	.010-.012 (.250-.255)

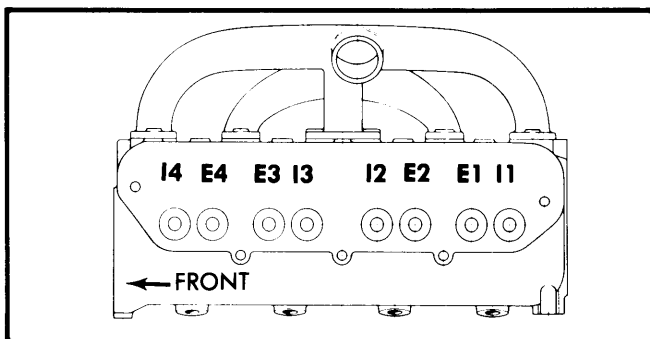

Fig. 4 View of Intake and Exhaust Valve Arrangement

COMBUSTION (SWIRL) CHAMBERS

Removal — Remove cylinder head from vehicle and remove injectors, injector studs, rocker arms, rocker arm mounting

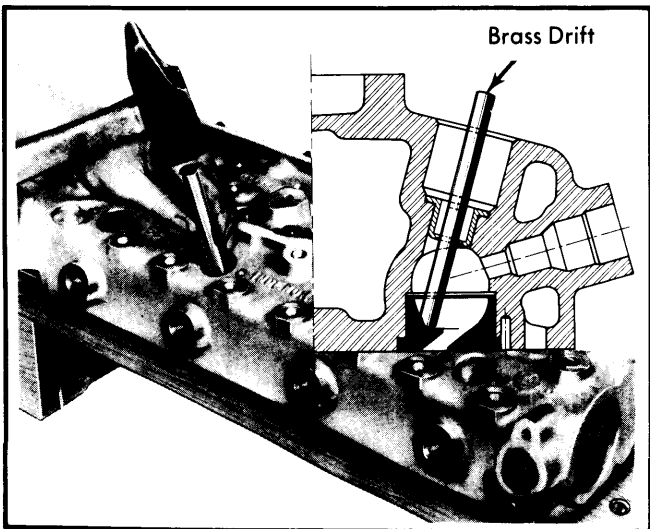

Fig. 5 Removing Combustion Chamber with Hammer and Drift

cylinder head. Tap drift LIGHTLY so as not to damage inner face of chamber. studs, manifolds and glow plugs. Using suitable drift (see illustration) carefully drive swirl chambers down and out of

CAUTION — If the swirl chamber twists and/or sticks in its bore, turn head over, tap chamber back into place with soft mallet, and start over again.

Inspection — 1) Inspect swirl chambers for distortion and cracks. Small cracks around the gas outlet are acceptable and do not effect engine operation. Replace all doubtful chambers. Measure thickness of shoulder and overall height of chamber.

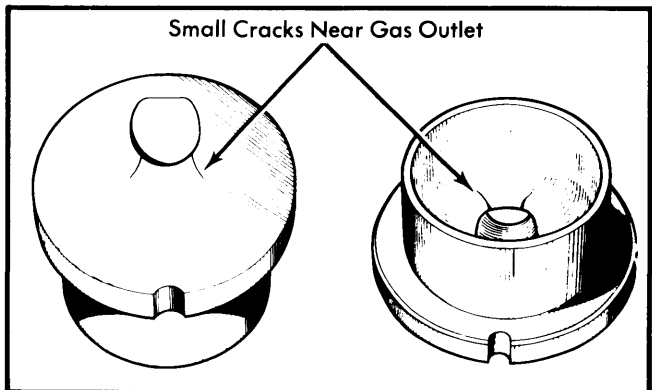

Fig. 6 View Showing Acceptable Cracks in Combustion Chamber

2) Place suitable truing punch (0.0139) over chamber bore in cylinder head, making sure dowel pin in punch is correctly located in head. Tap truing punch to make sure shoulder surface of bore is parallel with cylinder head. Slightly chamfer the edges of the chamber bore.

3) Measure depth of bore and depth to shoulder. Swirl chamber should protrude from cylinder head surface .000-.001" (.00-.03 mm) and clearance from swirl chamber to bottom of chamber bore should be .004-.020" (.10-.50 mm). To adjust clearances, chamber may be machined on shoulder surface and on bottom surface. Never machine face of chamber.

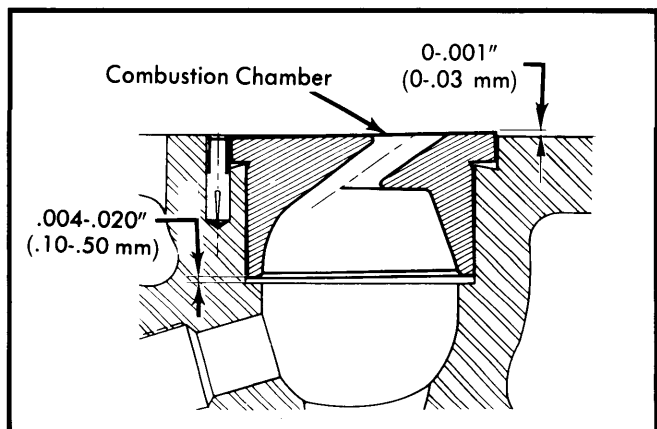

Fig. 7 Cross-Sectional View Showing Combustion Chamber Clearance and Protrusion

4-CYLINDER DIESEL & TURBO DIESEL (Cont.)

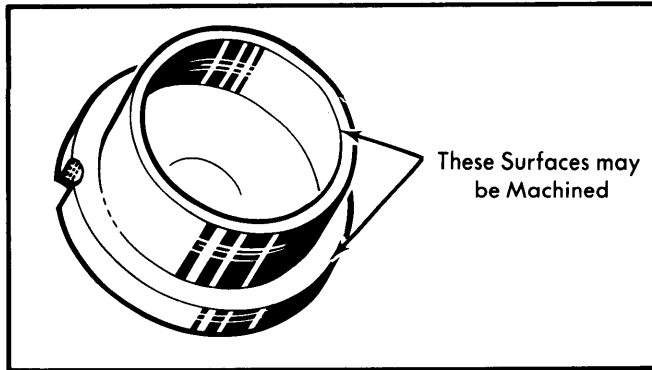

Fig. 8 Combustion (Swirl) Chamber with Detail of Machinable Surfaces

Installation — 1) Insert new wedge pins into the cylinder head and using chamfered drift, drive pins .028" (.7 mm) below cylinder head surface. Carefully insert the swirl chambers in the original bores and lightly tap into place with soft mallet.

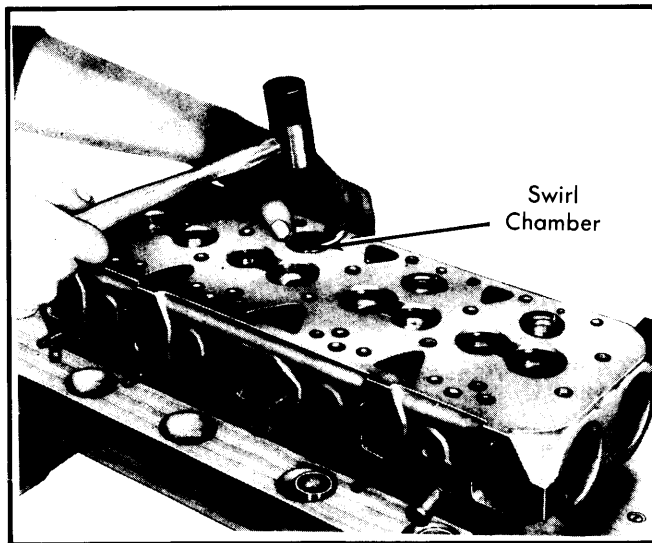

Fig. 9 Installing Combustion (Swirl) Chambers

2) Check for tight fit. If chamber is loose, chamber recess must be bored for oversize chamber. Using a dial gauge, check protrusion and parallelism with the cylinder head. Protrusion must be .000-.001" (.00-.03 mm) and difference between any two points must not exceed .001" (.03 mm).

PISTONS, PINS & RINGS

PISTON PIN & ROD ASSEMBLY

1) Remove engine from vehicle and drain oil. Remove oil pan, oil pump and cylinder head. Mark connecting rods for replacement in original location and remove connecting rod caps.

2) Push pistons up through top of cylinder block and replace connecting rod caps so they do not become mixed. Remove piston pin circlip and remove piston pin.

NOTE — Pistons, pins and rings are matched at factory and must not be intermixed.

3) Clean new piston assemblies with trichlorethylene. Do not remove piston rings to clean pistons. Make sure all protective coating has been removed from ring grooves. Blow with compressed air and check that piston rings move freely in grooves.

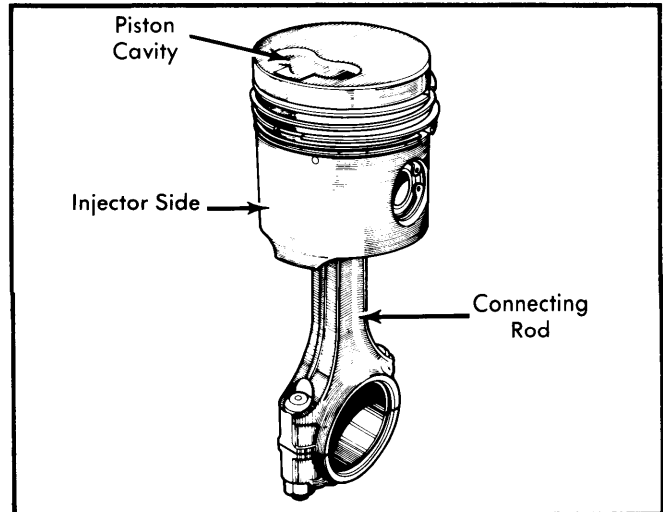

Fig. 10 Assembled View of Piston and Connecting Rod

4) Check fit of piston pin in connecting rod small end bushing. Ream bushing if too tight and replace bushing if too loose. Remove circlip from piston and partially remove piston pin. Position piston and rod so cavity on piston and reference marks on rod are on same side. Lubricate pin and install in piston. Replace circlip.

5) Do not remove connecting rod bolts. If any damage is evident, only 1 may be replaced. Lubricate pistons and bearings. Ensuring that compression rings are staggered 120° from slot of oil ring, use ring compressor and install each piston in its respective cylinder bore with cavity in piston facing injector side of engine.

NOTE — Take into account the pairing of pistons to bores (reference marks A, B, C, D, E, F). If only 1 reference mark is evident, all 4 bores are identical. "A" and "B" are standard sizes, all others oversize. See Fig. 11.

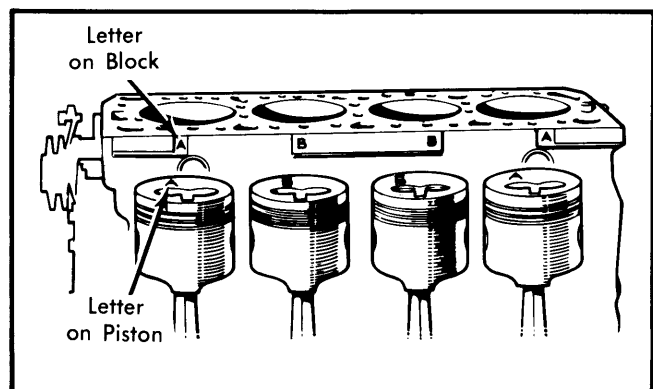

Fig. 11 Matching Pistons to Cylinder Bores

4-CYLINDER DIESEL & TURBO DIESEL (Cont.)

NOTE — On non-Turbo engines, turn engine over a few times by hand. Using a driving pawl (8.0110), check that moving parts torque does not exceed 44 ft. lbs. (59 N·m).

CRANKSHAFT MAIN & CONNECTING ROD BEARINGS

MAIN BEARINGS

Bearing caps are installed with the reference mark on injector side. Main bearing cap number two (as numbered from flywheel end) and number four are nearly identical. Bearing cap number two can be identified by letter after the part number.

THRUST BEARING ALIGNMENT

Thrust washers are located on both sides of center main bearing. Measure end play and replace washers as required. Thrust washers are available in standard thickness .091-.092" (2.30-2.33 mm) and oversize .098-.100" (2.50-2.53 mm). Install washers with oil grooves toward crankshaft.

REAR MAIN BEARING OIL SEAL

- 1) Crankshaft must be removed to replace oil seal. Work seal packing manually into cylinder block and into bearing cap grooves. Place seal forming mandrel (8.0110 A) onto packing and form packing into groove by tapping mandrel with a hammer.
- 2) Make sure packing is correctly seated in its groove without being crushed (see illustration). Cut seal packing clean flush with mating surface and follow same procedure for bearing cap.
- 3) Place side seals in grooves of bearing cap and hold seals in place with suitable shim tool (8.0110 CZ and 8.0110 B). Lubricate shims and bring into place in cylinder block, tapping down with hammer handle. Install and tighten bearing cap bolts and check that bearing cap has seated properly. Trim side seals with knife so they protrude .020" (.50 mm) above lower crankcase mating surface. Gauge (8.0110 D) can be used for measurement.

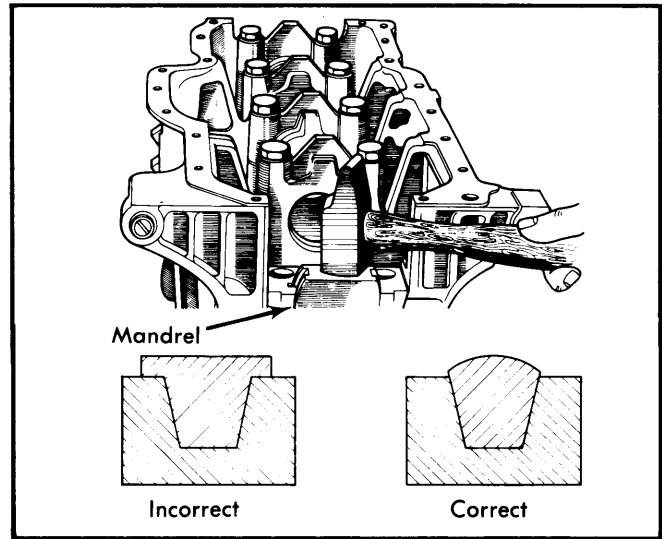

Fig. 12 Using a Mandrel and Mallet to Install Upper Rear Main Oil Seal

CAMSHAFT

TIMING CHAIN

- Removal** — 1) Remove the radiator, water pump, power steering and alternator belts. Remove the alternator and the cooling fan blade. If equipped with air conditioning, remove drive belt and protect condenser with plywood.
- 2) Remove the dampner pulley. Lock crankshaft using ring gear locking pawl (8.0110 L) on vehicle. Remove the timing chain housing. Turn crankshaft to bring keyway to vertical position. Unload chain tensioner as follows:
 - 3) For non-automatic loading tensioner (Sedis) unload by placing the lock in position No. 1. Push pad in all the way. Place lock in position No. 2. DO NOT attempt to dismantle the lock. For automatic loading tensioner (Brampton) wrap with wire. Remove from vehicle. To unload, remove wire. Retrieve the pad, spring and piston. Reassemble and lock together using a 3 mm hex wrench. Insert the assembly into the housing leaving a gap of .080" (2 mm). See Fig. 13.

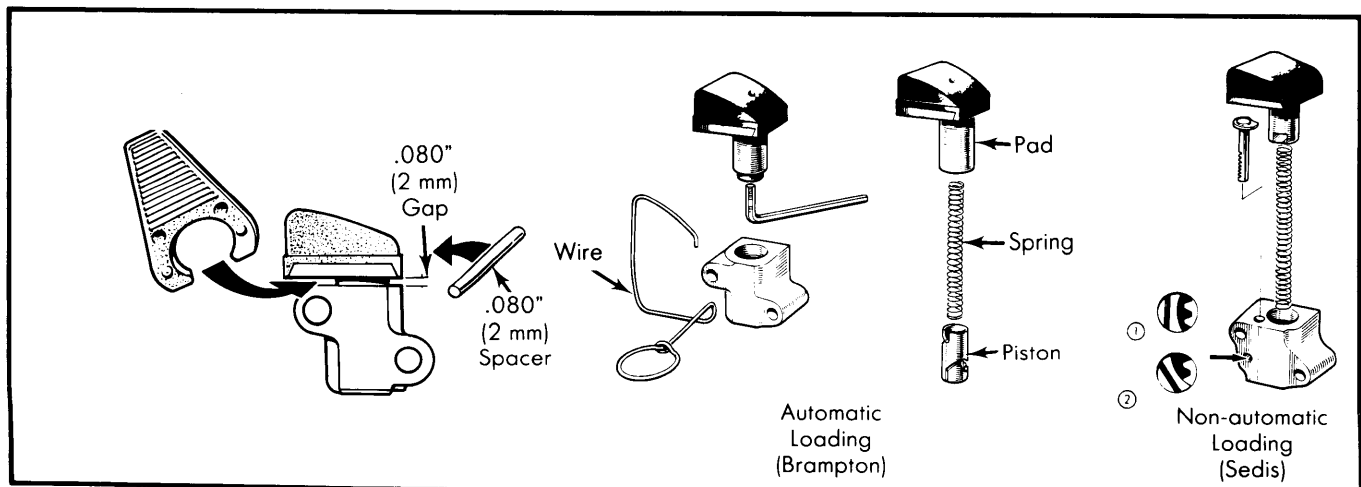

Fig. 13 Hydraulic Chain Tensioners

4-CYLINDER DIESEL & TURBO DIESEL (Cont.)

Installation — 1) Install the chain ensuring that the reference links align with each of the pinion references. See Fig. 14. If it becomes necessary to turn the camshaft, bring the crankshaft keyway to the horizontal plane (1/2 stroke of the piston).

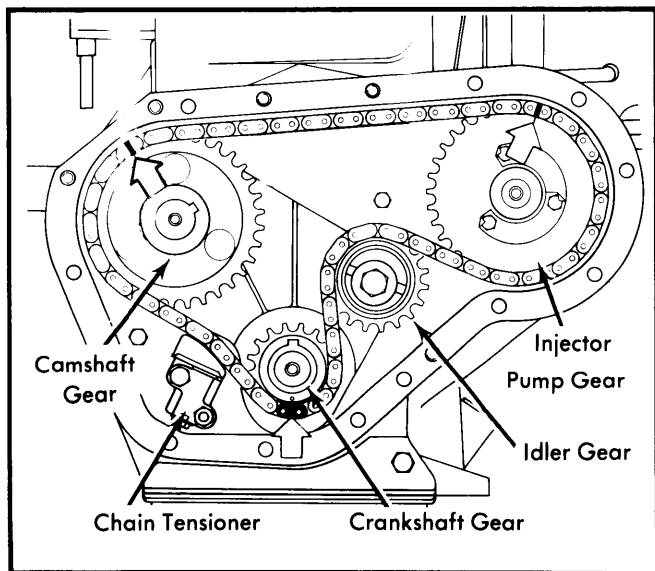

Fig. 14 Timing Chain Installed to Illustrate Timing Mark Alignment

2) Reinstall the hydraulic tensioner and support plate. Install the eccentric idler pinion and turn it in the direction of chain rotation until a play between chain and tensioner of .020-.040" (.5-1 mm) is obtained for Turbo, .040-.080" (1-2 mm) for non-Turbo engines.

3) Mount the tensioner to the engine. For non-automatic loading tensioner, place lock in position No. 1 and let pad release pad freely. For automatic loading tensioner, remove the spacer, push the pad in all the way, and release freely. Allow the tensioner to freely tension the chain (both types of tensioners). Rotate the crankshaft 1 full turn to ensure there is no piston-to-valve contact.

4) Reinstall the timing chain housing with a new gasket. After carefully cleaning the crankshaft pulley bolt threads, crankshaft threads, pulley, spacer and bearing faces, install the pulley. Lock the crankshaft using ring gear locking pawl (8.0110 L). Put a few drops of Loctite on the crankshaft threads.

5) Tighten the bolt to 40 ft. lbs. (54 N•m). Mark one of the bolt flats and a corresponding point on the pulley. Tighten the bolt an additional 60° (one flat on the bolt). Remove ring gear pawl. To complete installation, reverse removal procedures.

CAMSHAFT

Removal — With timing chain removed, remove the support plate bolts and remove the camshaft and timing case support plate as an assembly.

Installation — Install the timing case support plate and camshaft to the block together, using a new gasket. Bolt the support plate to the block, using Loctite on threads.

FUEL INJECTION PUMP

Removal — Remove battery. On the pump, disconnect fuel supply and return lines. Disconnect control cables, fuel shut-off electrovalve wire, and load sensor harness (if equipped). Remove injector pipes. Remove 2 front mounting bolts and pump rear support. Remove the pump and cap and all fuel openings.

Installation — 1) Remove engine valve cover. Bring the valves of No. 1 cylinder back to approximately 90°. Using a valve spring compressor, compress No. 4 exhaust valve spring and move rocker arm over.

2) Rotate engine back to rocking position of No. 1 cylinder. Remove half cones, washers and springs from No. 4 exhaust valve. Install a dial indicator onto No. 4 exhaust valve stem, using suitable supports (8.0177 ZZ).

3) Bring the engine to TDC at No. 4 cylinder. Zero the dial indicator. Rotate the engine backwards to .27" (7 mm) before TDC. Clean the hydraulic head on the injection pump and remove the inspection plug. Turn the pump shaft to bring the double tooth of the injection pump in line with the double groove of the engine pump hub pinion.

4) Coat a new gasket with grease and install on pump flange. Install pump on engine and install mounting bolts without tightening. Adjust timing as outlined in Adjustments.

Adjustment — 1) With injection pump mounting bolts loose, dial indicator attached to No. 4 cylinder exhaust valve, and engine at .27" (7 mm) before TDC, rotate the injection pump body away from the engine. Install dial indicator to pump using adapters (8.0117T, P, and S).

2) Turn engine and locate BDC and TDC points on the dial indicator. At BDC the pump dial indicator should have some preload. Zero the pump dial indicator at BDC. Bring piston No. 4 to TDC of compression stroke. Check zero point of engine dial indicator.

3) Turn engine 90° in reverse, and recheck pump dial indicator. Turn engine in normal direction of rotation and bring No. 4 piston to .038" (.97 mm) BTDC for non-Turbo models, and to .016" (.40 mm) BTDC for Turbo models. Rotate the pump toward the engine until the dial indicator indicates a lift of .020" (.50 mm).

4) Tighten pump mounting bolts, front and rear. Check timing by rotating the engine the normal direction 2 turns. Turn the engine back approximately 90°. Rotate engine slowly in normal direction while watching the pump dial indicator. Stop turning the engine when the indicator shows a lift of .020" (.50 mm).

5) No. 4 piston should then be at .038" (.97 mm) BTDC for non-Turbo models, and .016" (.40 mm) for Turbo models. If readjustment is necessary rotate the pump. Remove the dial indicators and supports. Reinstall the inspection plug with a new gasket. Install springs, washer and half cones of No. 4 exhaust valve and adjust clearance. Reinstall pipes, hoses and controls. Adjust cables and bleed fuel circuit.

4-CYLINDER DIESEL & TURBO DIESEL (Cont.)

ENGINE OILING

Crankcase Capacity — 5.29 qt.

Oil Filter — Full flow cartridge type.

Pressure Regulator Valve — Located in oil pump.

Normal Oil Pressure — Non-Turbo, 22 psi (1.6 kg/cm²) at idle, 42-58 psi (3.0-4.1 kg/cm²) at 4000 RPM. Turbo models, 37-55 psi (2.6-3.9 kg/cm²) at 2000 RPM, 46-65 psi (3.2-4.5 kg/cm²) at 4000 RPM.

ENGINE OILING SYSTEM

A high output, gear type oil pump, driven by camshaft, is mounted in oil pan.

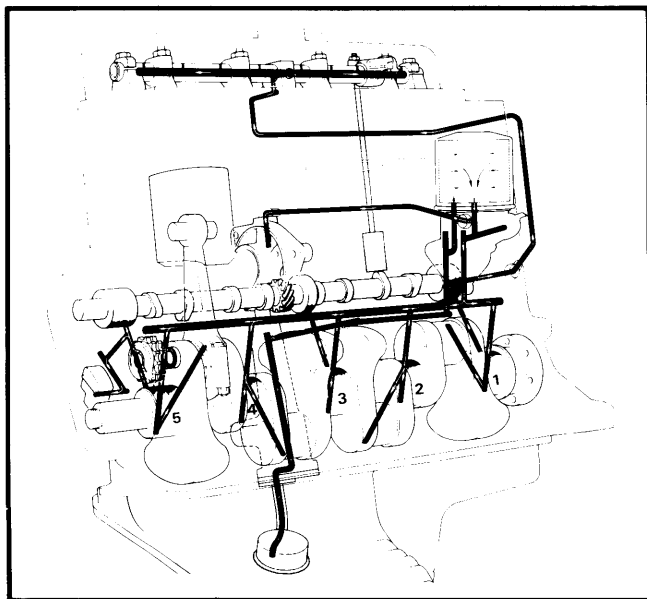

Fig. 15 Sectional View of Diesel Engine Oiling Circuit (Non-Turbo shown, Turbo Similar)

OIL PUMP

1) Insert the oil pump into its housing. Install the pump to its seat and position it with the positioning hole in the pump body aligned with the positioning screw hole in the block. Install the positioning screw and tighten. Install the acorn nut (cap nut) with a new gasket and tighten. Install the oil pump shaft end-play cap nut and tighten lightly without any shims.

2) Using a feeler gauge, measure the gap between the cap nut bearing face and the cylinder block through the slot provided. Remove the cap nut and install a shim to obtain correct end play. For Turbo, shim should be .020-.040" (.05-.1 mm) greater than feeler gauge reading, for non-Turbo models, shim should be .040" (1 mm) greater than feeler gauge reading. Reinstall cap nut and tighten.

ENGINE COOLING

Thermostat — Opens at 167° F (72° C) for non-Turbo models, 176° F (80° C) for Turbo models.

Cooling System Capacity — 10.57 qt.

WATER PUMP

1) Remove radiator, top hose, and fan belt. Disconnect heater hose from pump and the self-disengaging fan brush holder. Remove water pump.

2) To install, reverse removal procedures, noting the following: clean contact surfaces before installing new gasket.

SELF-DISENGAGING FAN

Driven by water pump shaft and controlled by a thermal contact-breaker. Fan engages at 178-182°F (81-83°C) and disengages at 151-158°F (66.5-70°C).

TIGHTENING SPECIFICATIONS

Application	Ft. Lbs. (N•m)
Cylinder Head	⊙
Clutch Housing-to-Block	43 (58)
Rocker Arm End Supports	
End Supports	14 (19)
Center Supports	34 (46)
Connecting Rod Caps	43 (58)
Main Bearing Caps	80 (109)
Eccentric Idler Gear	16 (22)
Crankshaft Pulley	⊙ 40 (54) plus 60°
Flywheel Bolts	56 (76)
Glow Plugs	16 (22)
Injection Pump Mounting Bolts	14 (19)
Oil Pump Cap Nut	65 (88)

⊙ — See text.

ENGINE SPECIFICATIONS

GENERAL SPECIFICATIONS

Year	Displ.		Carburetor	HP at RPM	Torque (Ft. Lbs. at RPM)	Compr. Ratio	Bore		Stroke	
	cu. ins.	cc					in.	mm	in.	mm
1981										
Turbo	140.6	2304	Fuel Inj.	80 @ 4150	136 @ 2000	21:1	3.700	94	3.267	83
Others	140.6	2304	Fuel Inj.	71 @ 4500	99 @ 2500	23:1	3.700	94	3.267	83

Peugeot Engines

6-205

E
N
G
I
N
E
S

4-CYLINDER DIESEL & TURBO DIESEL (Cont.)

ENGINE SPECIFICATIONS (Cont.)

VALVES							
Engine & Valve	Head Diam. In. (mm)	Face Angle	Seat Angle	Seat Width In. (mm)	Stem Diameter In. (mm)	Stem Clearance In. (mm)	Valve Lift In. (mm)
Turbo Intake	1.594 (40.5)	90°	90°	—	.3339-.3344 (8.480-8.495)	.0024 (.062)	—
Exhaust	1.319 (33.5)	90°	90°	—	.3330-.3337 (8.460-8.475)	.0032 (.082)	—
Others Intake	1.594 (40.5)	30°	30°	—	.3336-.3344 (8.473-8.495)	.0018 (.047)	.243 (6.173)
Exhaust	1.319 (33.5)	45°	45°	—	.3328-.3337 (8.453-8.475)	.0026 (.067)	.243 (6.173)

PISTONS, PINS, RINGS						
Engine	PISTONS	PINS		RINGS		
	Clearance In. (mm)	Piston Fit In. (mm)	Rod Fit In. (mm)	Rings	End Gap In. (mm)	Side Clearance In. (mm)
2304 cc ^①	.005-.006 (.13-.16)	Press Fit	No. 1	.014-.024 (.35-.60)
				No. 2	.014-.024 (.35-.60)
				Oil	.006-.012 (.16-.30)

① — Turbo specifications not available.

CRANKSHAFT MAIN & CONNECTING ROD BEARINGS							
Engine	MAIN BEARINGS				CONNECTING ROD BEARINGS		
	Journal Diam. In. (mm)	Clearance In. (mm)	Thrust Bearing	Crankshaft End Play In. (mm)	Journal Diam. In. (mm) ^①	Clearance In. (mm)	Side Play In. (mm)
2304 cc	2.1651-2.1661 (54.994-55.021)	.002-.004 (.05-.10)	Center	.003-.011 (.08-.29)	1.9678-1.9689 (49.984-50.011)	.002-.004 (.05-.10)

① — Turbo journal diameter 2.1651-2.1661" (54.994-55.021 mm).

VALVE TIMING				
Engine	INTAKE		EXHAUST	
	Open (BTDC)	Close (ABDC)	Open (BBDC)	Close (ATDC)
Turbo	12°	16°	56°	12°
Others	12°	40°	56°	12°