

## 810 6-CYLINDER DIESEL

### ENGINE CODING

#### ENGINE IDENTIFICATION

Engine serial number is stamped on right rear side of cylinder block below mating surface with head. 810 diesel engines are identified by the number LD28.

### ENGINE & CYLINDER HEAD

#### ENGINE

**NOTE** — Engine and transmission should be removed as a unit. Engine can be separated from transmission assembly after removal.

**Removal** — 1) Remove hood. Bleed off fuel pressure as follows: Start engine. Disconnect fuel pump relay No. 2 harness connector with engine running. After engine stalls, crank engine 2 or 3 times. Turn ignition switch off. Disconnect battery ground cable.

**NOTE** — Relay bracket is located on right side wheel well between battery and shock tower. Fuel pump relay No. 2 can be identified by the color of the wires used. The relay connector is the one with Light Green, Blue, Yellow/Red and Black/White wires.

2) Remove power steering pump and air conditioning compressor from engine, but DO NOT disconnect lines or hoses. Suspend pump and compressor with wire to prevent damage to hoses.

3) Drain cooling system and engine crankcase. Remove radiator hoses. Remove air cleaner. Disconnect transmission oil cooler lines and remove radiator and shroud. Remove lower engine splash guard.

4) Disconnect accelerator linkage. Disconnect wiring to starter, alternator, oil pressure switch, neutral switch, back-up light switch, EGR solenoid valve, electronic fuel injection harness and connector, auxiliary cooling fan, distributor and all wiring to thermostat housing.

5) Disconnect wiring to boost controlled deceleration solenoid valve. Disconnect engine ground cable to engine. Disconnect wire for block terminal. Disconnect fuel return hose and fuel charge hose, heater hoses, and all vacuum hoses. Disconnect wire to inhibitor switch and downshift solenoid.

6) Disconnect speedometer cable from rear extension housing. Remove center console, "C" ring, and control lever pin from transmission striking rod guide. Disconnect shift control lever.

7) Disconnect exhaust pipe from exhaust manifold. Disconnect exhaust pipe bracket from rear extension housing and tie exhaust pipe out of the way. Mark propeller shaft and pinion flange to aid in reassembly, then remove propeller shaft from vehicle. Plug rear of extension housing to prevent oil leakage.

8) Support transmission with a jack and remove rear engine mount. Use a hoist to raise engine and remove front engine mount attaching bolts. Raise engine and transmission and remove from vehicle as a unit.

**Installation** — To install, reverse removal procedures noting that the rear engine mount is attached first. Ensure proper

routing and attachment of all electrical harnesses, vacuum and liquid tubes. Refill all fluids to specified level before starting engine.

#### CYLINDER HEAD

**Removal** — 1) Disconnect battery ground cable. Drain cooling system and disconnect upper radiator hose and heater hoses. Release fuel pressure as described in engine removal section. Remove EGR valve and tube. Remove thermostat housing and bottom bypass inlet with hose. Remove intake and exhaust manifolds. Do not separate intake manifold.

2) Disconnect oil feed pipe to head and return line to oil pan. Remove injection tube and nozzle assemblies, including return hose and spill tube. Disconnect injection pump hoses. Remove oil cooler, oil lines and oil filter as an assembly. Remove front engine hoist bracket and power steering oil pump bracket.

3) Remove rocker arm cover, camshaft sprocket retaining bolt and camshaft sprocket. Remove cylinder head attaching bolts working outward from center of cylinder head. Remove bolts securing cylinder head to front cover. Remove head from block.

**NOTE** — Use special tool (ST1740001) to support timing chain so timing marks on crankshaft sprocket and timing chain will remain unchanged. This will simplify timing mark alignment during reassembly.

**Installation** — 1) Ensure that mating surfaces of cylinder head and block are clean, then install cylinder head and gasket without sealer. Number 1 piston should be at TDC on compression stroke.

**CAUTION** — Do not rotate crankshaft and camshaft separately or valves may hit heads of pistons.

2) Insert head bolts and tighten first 2 in tightening sequence to 14 ft. lbs. (19 N·m). Install and align sprockets and timing chain. Install remaining components in reverse order of removal, using new seals, gaskets and sealant where required.

3) Tighten head bolts in several steps in the sequence illustrated in Fig. 1 to final specified torque. Recheck torque after engine has been running for several minutes.

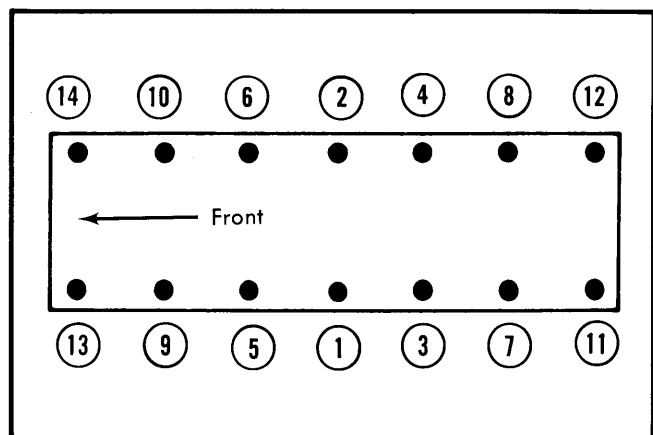

Fig. 1 Cylinder Head Tightening Sequence

## 810 6-CYLINDER DIESEL (Cont.)

## CAMSHAFT

## CAMSHAFT

**Removal** — Remove cylinder head. Remove glow plug connecting plate and glow plugs. Remove valve rocker springs. Loosen valve rocker pivot lock nuts and remove rocker arms by pressing down on spring. Use care not to lose valve rocker guide. Carefully remove camshaft from front of cylinder head.

**Installation** — Carefully install camshaft into cylinder head taking care not to damage bearings. Install camshaft locating plate with oblong groove of plate facing front of cylinder head. Install camshaft sprocket and tighten attaching bolt. Install remaining components in reverse of removal procedure, and tighten all nuts and bolts.

## CAMSHAFT BEARINGS

**NOTE** — Do not remove camshaft bearings. If bearings are removed, bearing centers will be out of alignment and proper reassembly will be difficult without center boring.

Measure inner diameter of camshaft bearings and outer diameter of camshaft journals. If excessively worn or damaged, replace camshaft and/or cylinder head assembly. In event of excess end play, replace thrust plate.

## ENGINE FRONT COVER

**Removal** — 1) Drain cooling system, disconnect hoses and remove radiator. Remove all drive belts, fan blade and pulley. Remove crankshaft pulley and water pump. Remove front dust cover, thermostat housing and bottom bypass inlet with hose. Disconnect injection tubes from injection nozzles and hoses to injection pump.

2) Remove front engine hoist bracket and power steering oil pump bracket. Remove injection pump and injection tubes as an assembly. Pull off injection pump drive crank pulley. Remove oil pump with drive spindle. Remove front cover attaching bolts and front cover.

**Installation** — Apply sealant to front cover gasket, front of cylinder block, and top of front cover. Install front cover on cylinder block. Tighten front cover-to-cylinder block bolts and cylinder head-to-front cover bolts. Reverse removal procedures to install remaining components.

## TIMING CHAIN

**Removal** — Remove engine front cover. Remove rocker arm cover, camshaft sprocket retaining bolt and camshaft sprocket. Remove timing chain, chain tensioner and chain guide. Remove oil thrower, crankshaft oil pump drive gear and crankshaft sprocket.

**Installation** — Install components in reverse of removal procedure while noting the following: When installing timing chain, camshaft sprocket or crankshaft sprocket, make sure camshaft and crankshaft keys point upward. Set timing chain so that plated links on chain line up with match marks on camshaft and crankshaft sprockets on right-hand side. Locate camshaft dowel pin in No. 1 hole in camshaft sprocket.

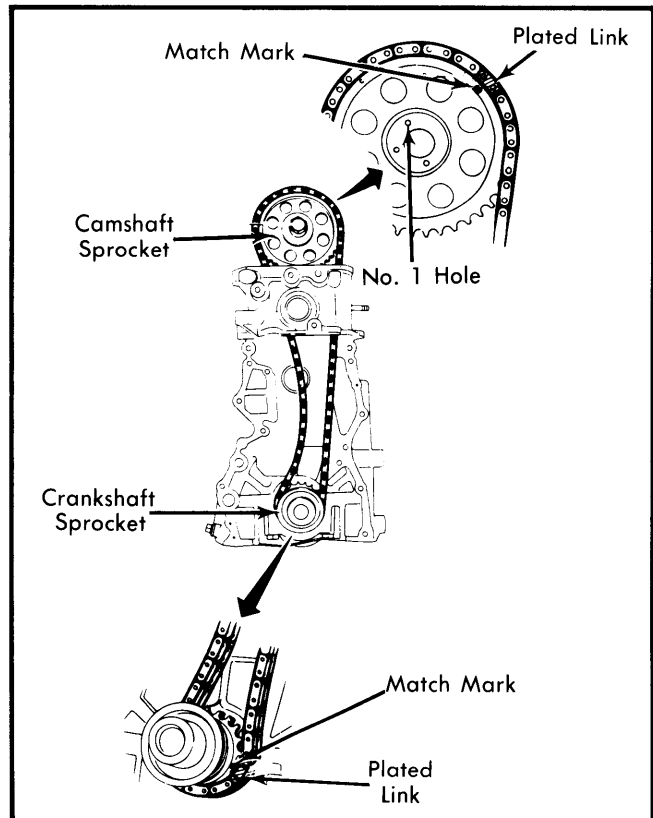

Fig. 2 Timing Chain and Sprocket Installation

## VALVES

## VALVE ARRANGEMENT

E-I-I-E-I-E-I-E-I-E-I-E (front to rear).

## VALVE GUIDE CHECKING

1) Measure clearance between valve stem and valve guide with the aid of a micrometer and hole gauge. Check diameter of valve stem in three places: top, center and bottom.

2) Insert hole gauge in valve guide bore and measure at center. Subtract highest reading of valve stem diameter from valve guide bore to obtain clearance.

**NOTE** — As a quick check, a valve may be inserted into valve guide and moved either left or right (parallel with rocker arm). If its tip moves .008" (.2 mm) or more, clearance is beyond maximum limit of .004" (.1 mm).

## VALVE GUIDE REPLACEMENT

1) If clearance is beyond acceptable limits and valve stem is not worn, the valve guide must be replaced. To replace guide, heat cylinder head to 300-400°F (150-200°C) and use suitable drift (ST110330000) to drive old guides out from combustion chamber side toward rocker arm cover.

2) With head at room temperature, ream valve guide hole to .481" (12.2 mm). Reheat cylinder head and install new guide. Use suitable reamer (ST110320000) to finish stem bore to .315" (8.0 mm) and reface valve seat surface.

## 810 6-CYLINDER DIESEL (Cont.)

### VALVE SEAT INSERTS

Check valve seats for pitting at valve contact surface. Valve seat inserts of .020" (.5 mm) oversize are available if necessary.

### VALVE STEM OIL SEALS

An oil seal is installed on all intake and exhaust valve stems inside of valve spring.

### VALVE SPRINGS

**Removal** — With cylinder head removed, remove glow plug connecting plate and glow plugs. Remove camshaft as previously outlined. Compress valves and remove valve keepers. Remove compressing tool, then remove spring retainer, valve spring, oil seal and valve spring seat. Keep components in correct order for installation.

**Installation** — Install spring seat and fit oil seal onto valve guide. Install valve springs, spring retainers, keepers and rocker guides. Install camshaft. Press valve springs down using a screwdriver and install rocker arms. Install valve rocker springs.

### VALVE SPRING INSTALLED HEIGHT

Valve spring must be less than .087" (2.2 mm) out of square. Valve spring installed height is 1.575" (40.0 mm) with valve closed and 1.181" (30.0 mm) with valve open. If spring height, pressure or squareness do not meet specifications, replace spring.

### VALVE ADJUSTMENT

Valves can not be adjusted while engine is in operation. Cold settings are shown to provide initial clearance after assembly. Warm engine to operating temperature and remove valve rocker arm cover. Rotate crankshaft so No. 1 exhaust cam lobe points up and adjust exhaust valve clearance on No. 1, 4 and 5 cylinders. Adjust intake valves on No. 2, 4 and 6 cylinders. Rotate crankshaft 360° so that lobe of No. 1 exhaust valve points down. Adjust exhaust valve clearance on No. 2, 3 and 6, and intake clearance on No. 1, 3 and 5 cylinders.

Valve Adjustment Clearances		
Valve	Hot	Cold
Intake .....	.010" (.25 mm)	.007" (.18 mm)
Exhaust .....	.012" (.30 mm)	.010" (.25 mm)

## PISTONS, PINS & RINGS

### PISTON & ROD ASSEMBLY

**Removal & Installation** — 1) With cylinder head, front cover and oil pan removed, remove connecting rod nuts. Remove rod cap with bearing half. Push piston/rod assembly with bearing half up and out through top of engine. Rod caps must be kept with their respective piston and rod assemblies as caps are not interchangeable.

2) To install piston and connecting rod assembly, thoroughly oil rings, piston and cylinder wall. Make sure ring gaps are situated approximately 180° apart and not on thrust side of piston or in line with piston pin. Make sure bearing halves are properly seated in connecting rod and cap.

3) Install a ring compressor and compress rings. Install piston in cylinder. There is a grade mark stamped in the top of each piston. Be sure to install piston with this mark toward the front of the engine.

4) With piston installed in cylinder, and connecting rod and bearings seated against crankshaft journal, install rod caps to their respective piston and rod assembly. Oil jet of connecting rod should face right side of cylinder block. Install cylinder head, front cover and oil pan.

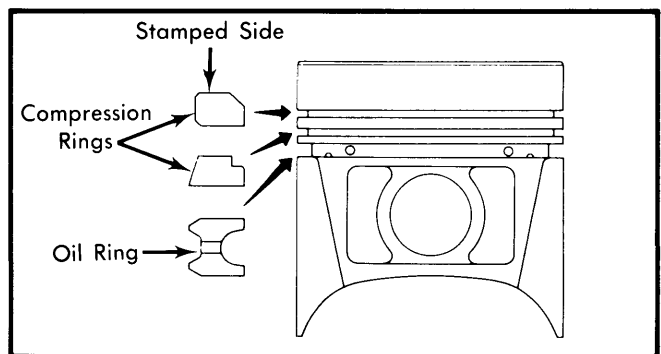

Fig. 3 Installation Order of Piston Rings

### FITTING PISTONS

1) Visually inspect cylinder block for cracks or flaws. Measure block deck for warpage. If warpage exceeds .004" (.10 mm), grind deck to correct. Using a bore gauge, measure cylinder for out-of-round or excessive taper. If cylinder bore out-of-round or taper exceeds .0008" (.02 mm), refinish cylinder bore. When any one cylinder is bored, all cylinders must be bored.

2) Determine piston oversize according to amount of wear in cylinder (see specifications). By measuring piston at thrust face and adding mean of piston-to-cylinder clearance, finish hone of cylinder may be determined.

3) After honing cylinder to final fit, measure piston-to-cylinder clearance using pull scale and feeler gauge. With piston and cylinder at room temperature (70°F, 20°C), extracting force to pull scale should be 1.3-2.6 lbs. (.6-1.2 kg) using a .0024" (.06 mm) feeler gauge.

Piston Specifications	
Piston Size In. (mm)	Piston Diameter In. (mm)
Standard .....	3.3244-2.3264 (84.44-84.49)
.020 (.50) O/S .....	3.3441-3.3461 (84.94-84.99)
.040 (1.00) O/S .....	3.3638-3.3657 (85.44-85.49)

### PISTON PINS

1) With piston and rod assembly heated to about 150°F (65°C), drive out piston pin with suitable drift. Be sure to

## 810 6-CYLINDER DIESEL (Cont.)

remove piston pin snap rings before driving out pin. Using micrometer and hole gauge, measure diameter of piston pin and piston pin hole in piston. Use these measurements to determine pin to piston clearance. If wear exceeds .0002" (.004 mm), replace piston and pin.

2) To assemble piston and connecting rod, heat piston with a heater or hot water to about 150°F (65°C) and insert piston pin into piston while holding piston and connecting rod in proper alignment. Assemble so that the oil hole in the connecting rod is on the same side as the combustion chamber in the top of the piston.

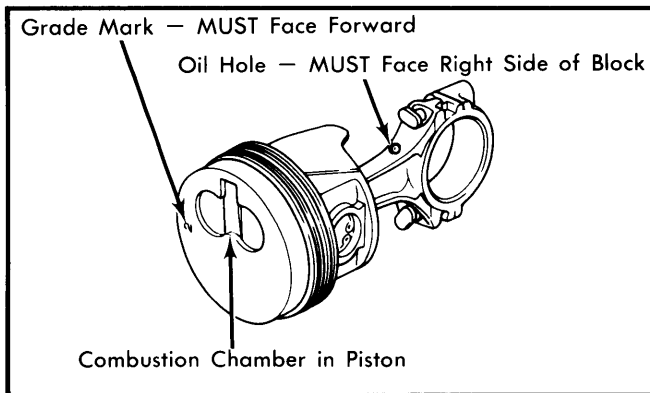

Fig. 4 Piston and Connecting Rod Alignment

## CRANKSHAFT MAIN & CONNECTING ROD BEARINGS

### CRANKSHAFT

**Removal** - 1) With engine removed from vehicle, remove cylinder head, front cover and oil pan. Remove flywheel and end plate. Remove oil pump, chain tensioner and chain guides. Remove timing chain, oil thrower, crankshaft oil pump drive gear and crankshaft sprocket.

2) Remove piston and rod assemblies. Remove main bearing caps using a special tool (KV101041S0) to remove center and rear caps. Remove rear oil seal, then remove crankshaft. Remove upper main bearing halves.

**NOTE** - Keep all main bearing caps in order to aid in reassembly.

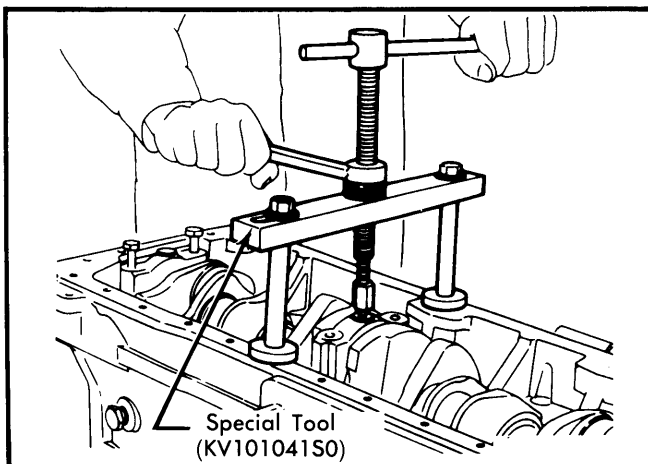

Fig. 5 Removing Center Main Bearing Cap

**Inspection** - Check shaft journals and crankpins for scoring, wear, or cracks. Taper and out-of-round of journals and crankpins must not exceed .0012" (.03 mm). Check crankshaft for bend using a dial indicator at center journal of crankshaft. If bend exceeds .002" (.05 mm), which is half of indicator reading, replace crankshaft. Check main drive shaft pilot bearing at rear of crankshaft for wear or damage and replace if necessary.

**Installation** - 1) Install main bearing halves to engine block ensuring that all bearings are on correct journal. Journal No. 4 requires a thrust bearing. Bearing for journal No. 1 is the same as for journal No. 7. Upper bearing halves have an oil hole and groove and are not interchangeable with lower bearing halves.

2) Apply oil to main bearing surface and install crankshaft. Apply sealant to each side of rear main bearing cap and corners of cylinder block contact point. Install bearing caps so arrow faces front of engine. Shift crankshaft toward front of engine, then tighten main bearing caps in 2 or 3 steps, starting at center bearing and working out. Ensure crankshaft rotates smoothly.

3) Check crankshaft end play. If not within specifications, replace center thrust bearing. Install side seals in rear main bearing cap after applying sealer to seals. Install rear oil seal. Install rear end plate and flywheel. Install piston and rod assemblies.

4) Install cylinder head, crankshaft sprocket, crankshaft oil pump drive gear, chain drive sprocket, oil thrower, and timing chain. Install chain guides and tensioner, front cover, oil pump and oil pan. Install remaining components in reverse of removal procedure.

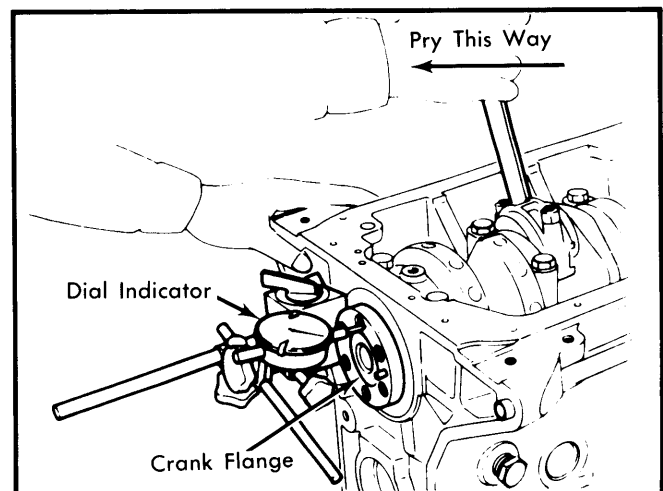

Fig. 6 Checking Crankshaft End Play

### MAIN BEARINGS

Check all bearings for scoring or wear and replace if damage is found. Clean oil from crankshaft and place a strip of Plastigage on crankshaft journal. Install main bearing cap with bearing installed, and tighten to 51-61 ft. lbs. (69-83 N·m).

**NOTE** - Plastigage should run parallel with crankshaft and journal and should not block oil hole. Do not turn crankshaft while Plastigage is inserted.

## 810 6-CYLINDER DIESEL (Cont.)

2) Remove cap and measure width of Plastigage at widest point using gauge provided with Plastigage. If clearance is not to specifications, replace bearings. Bearings are available in undersizes of .01" (.25 mm), .02" (.50 mm), .03" (.75 mm) and .04" (1.00 mm).

### CONNECTING ROD BEARINGS

Check connecting rod bearing clearance. Use Plastigage as in checking main bearing clearance. Tighten connecting rod caps to 33-40 ft. lbs. (45-54 N·m). Bearings are available in undersizes of .0024" (.06 mm), .0047" (.12 mm), .01" (.25 mm), .02" (.50 mm), .03" (.75 mm) and .04" (1.00 mm).

### ENGINE OILING

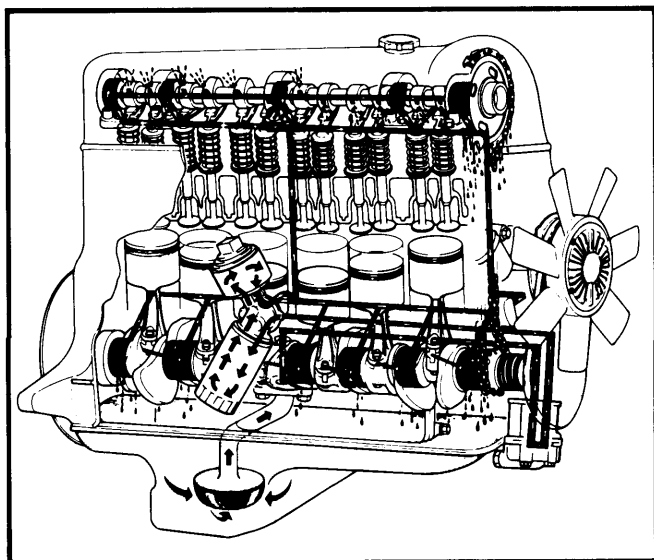

Fig. 7 Cutaway View of Engine Oiling System

### ENGINE OILING SYSTEM

Oil drawn from oil pan passes through a screen to oil pump. Oil is delivered to full flow oil filter, oil cooler, and main oil gallery. Main oil gallery supplies oil to crankshaft main bearings and drilled passages in crankshaft. Oil sprayed from jet holes on connecting rods lubricates cylinders and piston pins.

Oil from main gallery lubricates chain tensioner and timing chain. A center oil hole in the crankshaft center bearing feeds camshaft bearings on cylinder head. Valve rocker mechanism is lubricated through oil gallery in camshaft and through a small channel at base circle portion of each cam. Rocker arms and valves are lubricated intermittently through small holes or oil pipe.

**Crankcase Capacity** – 6.5 quarts (includes filter).

**Oil Filter** – Full-flow, with disposable cartridge.

**Oil Pressure** – 45-55 psi (3.1-3.7 kg/cm<sup>2</sup>).

### OIL PUMP

**Removal** – Oil pump assembly is installed to bottom of front cover by four bolts. Pump is driven by oil pump drive spindle assembly which is in turn driven by gear on crankshaft. To remove pump, drain engine oil, remove 4 retaining bolts and remove oil pump body together with drive spindle.

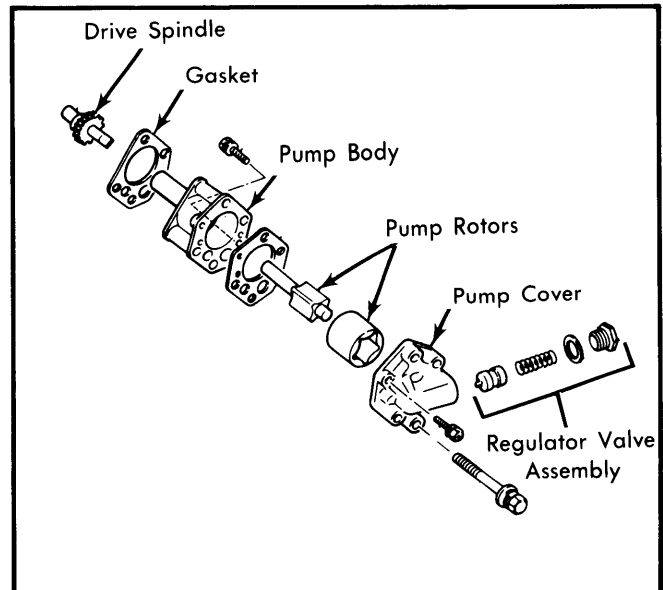

Fig. 8 Exploded View of Oil Pump Assembly

**Inspection** – Disassemble oil pump and wash all parts thoroughly in clean solvent. Inspect for signs of unusual wear or damage. Check all clearances to specifications. Pump is serviced as a complete assembly only. If components are not to specifications, replace entire pump assembly.

**Installation** – Fill pump with oil and reverse removal procedure to install.

### Oil Pump Specifications

Application	Clearance In. (mm)
Rotor Tip Clearance .....	Less Than .008 (.20)
Outer Rotor-to-Body .....	Less Than .020 (.50)
Rotor-to-Cover .....	Less Than .002 (.06)
Rotor Side Clearance .....	Less Than .001 (.03)

### ENGINE COOLING

#### WATER PUMP

Centrifugal type pump with aluminum body. To remove, drain cooling system and remove fan shroud. Remove fan belts, fan, and pulley. Remove pump attaching bolts and remove water pump from front cover.

**Thermostat** – 180°F (82°C).

**Cooling System Capacity** – 11.6 quarts.

**Radiator Cap** – 13 psi (.9 kg/cm<sup>2</sup>).

# Datsun Engines

## 810 6-CYLINDER DIESEL (Cont.)

### TIGHTENING SPECIFICATIONS

Application	Ft. Lbs. (N·m)
Cylinder Head .....	87-94 (118-128)
Connecting Rod .....	33-40 (45-54)
Camshaft Gear .....	87-116 (118-158)
Crankshaft Pulley .....	101-116 (137-158)
Drive Plate Bolt .....	101-116 (137-158)
Glow Plug .....	14-18 (19-25)
Intake/Exhaust Manifolds	
8M Bolt .....	12-15 (16-20)
10M Bolt .....	24-27 (33-37)
Injection Pump Nut .....	12-15 (16-20)
Main Bearing Caps .....	51-61 (69-83)
Rocker Pivot Lock Nuts .....	36-43 (49-59)
Oil Pump Mounting Bolts .....	96-132 INCH Lbs. (11-15)

### ENGINE SPECIFICATIONS

#### GENERAL SPECIFICATIONS

Year	Displ.		Carburetor	HP at RPM	Torque (Ft. Lbs. at RPM)	Compr. Ratio	Bore		Stroke	
	cu. ins.	cc					in.	mm	in.	mm
1981 LD28	170.9	2793	Fuel Inj.	.....	.....	.....	3.33	84.5	3.27	83.0

#### VALVES

Engine & Valve	Head Diam. In. (mm)	Face Angle	Seat Angle	Seat Width In. (mm)	Stem Diameter In. (mm)	Stem Clearance In. (mm)	Valve Lift In. (mm)
2793 cc Int.	1.54 (39.0)	45.5°	45°	.075 (1.91)	.3136-.3142 (7.965-7.980)	.0008-.0021 (.020-.053)	.....
Exh.	1.26 (32.0)	45.5°	45°	.061 (1.56)	.3128-.3134 (7.945-7.960)	.0016-.0029 (.040-.073)	.....

#### PISTONS, PINS, RINGS

Engine	PISTONS Clearance In. (mm)	PINS		RINGS		
		Piston Fit In. (mm)	⊙ Rod Fit In. (mm)	Rings	End Gap In. (mm)	Side Clearance In. (mm)
2793 cc	.0020-.0028 (.05-.07)	0-.0002 (0-.004)	.0010-.0017 (.025-.044)	No. 1	.0067-.0100 (.17-.26)	.0024-.0039 (.060-.100)
				No. 2	.0079-.0138 (.20-.35)	.0016-.0013 (.040-.080)
				Oil	.0118-.0177 (.30-.45)	.0012-.0028 (.030-.070)

⊙ — Interference Fit.

# Datsun Engines

6-101

E  
N  
G  
I  
N  
E  
S

## 810 6-CYLINDER DIESEL (Cont.)

### ENGINE SPECIFICATIONS (Cont.)

CRANKSHAFT MAIN & CONNECTING ROD BEARINGS							
Engine	MAIN BEARINGS				CONNECTING ROD BEARINGS		
	Journal Diam. In. (mm)	Clearance In. (mm)	Thrust Bearing	Crankshaft End Play In. (mm)	Journal Diam. In. (mm)	Clearance In. (mm)	Side Play In. (mm)
2793 cc	2.1631-2.1636 (54.942-54.955)	.0008-.0024 (.020-.062)	No. 4	.002-.007 (.05-.18)	1.9670-1.9675 (49.961-49.974)	.0008-.0024 (.020-.062)	.008-.012 (.2-.3)

VALVE SPRINGS			
Engine	Free Length In. (mm)	PRESSURE Lbs. @ In. (kg @ mm)	
		Valve Closed	Valve Open
2793 cc	1.9594 (49.77)	51@1.575 (23@40.0)	115@1.181 (52@30.0)

VALVE TIMING				
Engine	INTAKE		EXHAUST	
	Open (BTDC)	Close (ABDC)	Open (BBDC)	Close (ATDC)
2793 cc	14°	38°	60°	8°

CAMSHAFT			
Engine	Journal Diam. In. (mm)	Clearance In. (mm)	Lobe Lift In. (mm)
2793 cc	1.8878-1.8883 (47.949-47.962)	.0015-.0026 (.038-.067)	.....