

200SX, 510 & PICKUP 4-CYLINDER

ENGINE CODING

ENGINE IDENTIFICATION

Engine number is stamped on left side of cylinder block on 200SX and Pickup models and right side of block on 510 models.

Engine Identification	
Application	Code
200SX	Z20E
510	Z20S
Pickup	Z22

ENGINE & CYLINDER HEAD

ENGINE

NOTE — It is recommended that engine and transmission be removed as a unit. Engine can then be separated from transmission.

Removal (200SX) — 1) Reduce fuel pressure by disconnecting harness connector at upper-right fuel pump relay while engine is running. After stalling occurs, crank engine 2 or 3 times. Turn ignition to "OFF" and reconnect harness connector.

2) Mark hood and hinges for alignment on reassembly, then remove hood. Disconnect battery ground cable. Drain cooling system, transmission and crankcase. Disconnect all engine-to-chassis cables, hoses and wires.

3) On models with air conditioning, dismount compressor by removing mounting bolts and moving compressor aside toward fender. DO NOT discharge gas from compressor or system or separate refrigerant lines. Hold compressor out of way with wire to prevent interference with engine removal.

4) On models with power steering, dismount steering pump by removing belt and mounting bolts. Move aside toward fender and secure with wire to prevent interference with engine removal. DO NOT allow oil to drain from pump.

5) On manual transmission models, detach rubber boot, remove nut from shift lever and remove shift lever. On automatic transmission models, disconnect joint between control lever and selector rod. Remove oil cooler lines. On all models, remove radiator hoses, shroud and radiator.

6) Disconnect speedometer cable, downshift solenoid and inhibitor switch wires. On manual transmission models, remove clutch operating cylinder. On automatic transmission models, disconnect vacuum hose. On all models, mark for reassembly and remove propeller shaft. Remove front exhaust pipe.

7) Plug end of transmission. Attach a lifting hoist to engine and raise enough to take weight off engine mounts. Remove front and rear engine mounting bolts. Pull engine forward and carefully remove engine and transmission as an assembly.

Removal (510) — 1) Disconnect battery ground cable. Drain cooling system, transmission and crankcase. Mark hood and hinges for alignment on reassembly, then remove hood. Remove grille.

2) Remove radiator hoses. Disconnect oil cooler lines and remove splash board on models with automatic transmission.

Disconnect inhibitor switch, downshift solenoid and engine ground cable wire connections.

3) Remove radiator and shroud. Remove all hoses and tubes to air cleaner, then remove air cleaner. Disconnect all engine-to-chassis cables, hoses and wires. Remove EGR vacuum reservoir tank and EGR valve.

4) On models with air conditioning, dismount compressor by removing mounting bolts and moving compressor aside toward fender. DO NOT discharge gas from compressor or system or separate refrigerant lines. Hold compressor out of way with wire to prevent interference with engine removal.

5) Disconnect speedometer cable. On manual transmission models, detach rubber boot, remove nut from shift lever and remove shift lever. Remove clutch operating cylinder. On automatic transmission models, disconnect joint between control lever and selector rod.

6) Remove front exhaust pipe. Mark for reassembly and remove propeller shaft. Plug end of transmission. Attach a lifting hoist to engine and raise enough to take weight off engine mounts. Remove front and rear engine mounting bolts. Pull engine forward and carefully remove engine and transmission as an assembly.

Removal (Pickup) — 1) Disconnect battery ground cable. Drain cooling system, transmission and crankcase. Mark hood and hinges for reassembly, then remove hood. Remove all hoses and tubes to air cleaner, then remove air cleaner. Disconnect all engine-to-chassis cables, hoses and wires.

2) On models with air conditioning, dismount compressor by removing mounting bolts and moving compressor aside toward fender. DO NOT discharge gas from compressor or system or separate refrigerant lines. Hold compressor out of way with wire to prevent interference with engine removal.

3) On manual transmission models, detach rubber boot, remove nut from shift lever and remove shift lever. Remove clutch operating cylinder. On automatic transmission models, disconnect joint between control lever and selector rod. Remove oil cooler lines.

4) Remove radiator hoses, shroud and radiator. Disconnect speedometer cable and all switch wires on transmission case. Remove parking brake cable. Disconnect vacuum hose and oil pipes on automatic transmission models.

5) On 2WD models, mark for reassembly and remove propeller shaft. On 4WD models, remove front propeller shaft and pre-propeller shaft from transfer case. Remove front differential mounting bolts. On all models, remove front exhaust pipe and plug end of transmission.

6) Attach a lifting hoist to engine and raise enough to take weight off engine mounts. Remove front and rear engine mounting bolts. Remove differential mounting crossmember (4WD). Pull engine forward and carefully remove engine and transmission as an assembly.

Installation (All Models) — Replace any rubber engine mounts showing signs of deterioration or separation. Ensure proper placement of all engine mountings. Reverse removal procedures to complete installation.

CYLINDER HEAD

Removal — 1) Reduce fuel pump pressure (200SX). Disconnect battery ground cable. Drain cooling system. Disconnect spark plug wires from spark plugs. Remove radiator and heater hoses. Disconnect drive belts, alternator bracket and adjusting bar. Move alternator aside.

200SX, 510 & PICKUP 4-CYLINDER (Cont.)

2) Remove fan, pulley and water pump. If equipped with air conditioning and/or power steering, remove as outlined in engine removal procedure. Disconnect throttle linkage. Remove air cleaner. Disconnect all cables, hoses and wires running from cylinder head to chassis or engine. Disconnect all hoses and vacuum lines from intake manifold to cylinder head or engine block.

3) Remove fuel pump, carburetor (510 and Pickup), and intake manifold. Remove EGR tube on all models. Remove air induction tubes on 510 and Pickup. Remove front exhaust pipe, exhaust manifold and rocker cover.

4) Turn crankshaft so No. 1 piston is at TDC on compression stroke. Paint aligning marks on timing chain and camshaft sprocket to aid in installation.

5) Remove camshaft sprocket and use retainer tool (KV10105800) to support timing chain as shown in Fig. 1. Remove cylinder head attaching bolts in reverse of sequence shown in Fig. 2. Remove cylinder head.

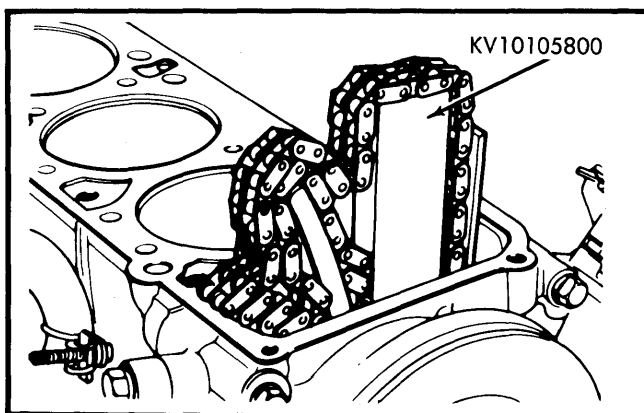

Fig. 1 Holding Timing Chain with Special Support Tool

Installation — 1) Ensure that mating surfaces of cylinder head and block are clean, then install cylinder head and gasket without sealer. Number 1 piston should be at TDC on compression stroke and camshaft sprocket location notch and plate oblong groove aligned.

2) Insert head bolts and tighten No. 1 and No. 2 to 14 ft. lbs. (19 N·m). Install and align sprockets and timing chain. Install remaining components in reverse order of removal, using new seals, gaskets and sealant where required.

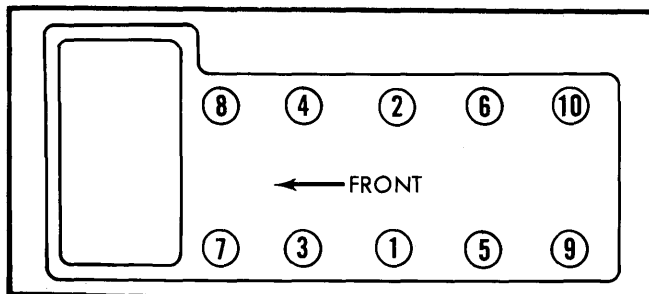

Fig. 2 Cylinder Head Tightening Sequence

3) Tighten head bolts in several steps in the sequence illustrated in Fig. 2 to final specified torque. Recheck torque after engine has been running for several minutes.

CAMSHAFT

CAMSHAFT

Removal — With cylinder head removed, evenly loosen rocker arm bolts from outside in sequence. DO NOT remove bolts from each end of rocker arm shaft or assembly will spring apart. Remove rocker arm assembly. Carefully remove camshaft.

Installation — Install camshaft on cylinder head with front camshaft dowel pin facing up. Install rocker arm assembly aligning to dowel pin on cylinder head. Place cylinder head on wooden blocks to allow for valve space. Tighten rocker arm bolts in 2 or 3 steps in outward sequence from center bracket.

CAMSHAFT BEARINGS

Measure inner diameter of camshaft bearing and outer diameter of camshaft journal. If wear or damage is excessive, replace cylinder head assembly.

ENGINE FRONT COVER

Removal — With engine removed from vehicle and mounted on engine stand, remove oil pump and drive spindle. Remove front cover attaching bolts and front cover.

Installation — Apply sealant at mating corners of oil pan, cylinder head and front cover. Oil seal should be coated with engine oil before installation in cover and before cover is installed. Use new gasket and install cover.

NOTE — Check height difference between cylinder block and front cover upper face. Difference must not exceed .006" (.15 mm).

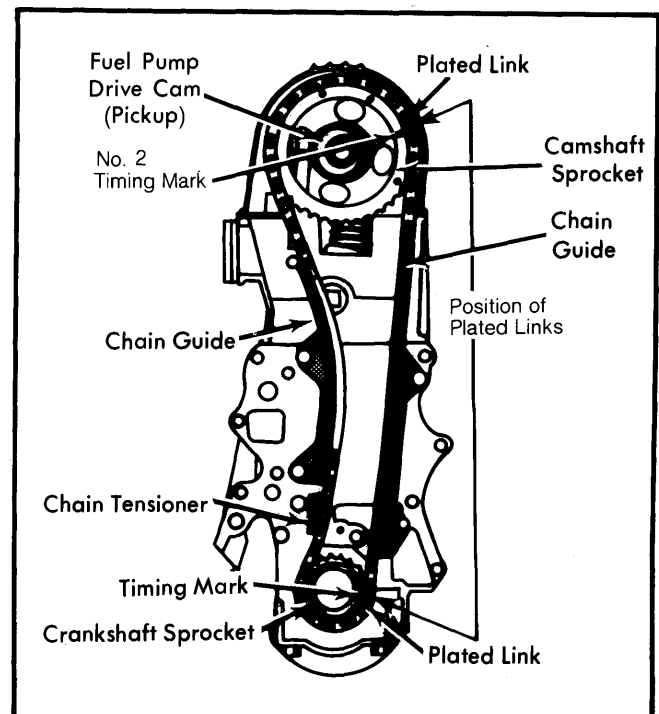

Fig. 3 Timing Chain and Sprocket Alignment

200SX, 510 & PICKUP 4-CYLINDER (Cont.)

TIMING CHAIN & GEARS

Removal — Remove valve cover. On Pickup and 510, remove fuel pump and fuel pump drive cam. Remove camshaft drive sprocket and engine front cover. Remove timing chain tensioner and guides. Remove timing chain, oil thrower, crankshaft worm gear and chain drive sprocket.

Installation — Position crankshaft and camshaft keyways straight up. Align No. 2 hole in camshaft sprocket with pin in camshaft flange. Ensure timing chain plated links align with marks on both sprockets (No. 2 on camshaft sprocket). To complete installation, reverse removal.

VALVES

VALVE ARRANGEMENT

Right Side — All Intake
Left Side — All Exhaust

NOTE — Camshaft **MUST** be removed to take out valves. See Camshaft Removal & Installation in this Section.

VALVES

Removal — With camshaft removed, remove valves using valve spring compressor (ST12070000). Keep disassembled parts in order. Check each valve for worn, damaged or deformed heads or stems.

Installation — Install valve spring seat and oil seal on valve guide. Place springs in position with close-coiled (painted) end toward cylinder head. Use compressor and install valve collets and keepers.

VALVE GUIDE SERVICE

1) Measure clearance between valve stem and valve guide, with aid of micrometer and hole gauge. Check diameter of valve stem in three places: top, center, and bottom.

2) Insert hole gauge in valve guide bore and measure at center. Subtract highest reading of valve stem diameter from valve guide bore to obtain clearance.

NOTE — As a quick check, a valve may be inserted into valve guide and moved either left or right, (parallel with rocker arm). If tip moves .008" (.2 mm) or more, clearance is beyond maximum limit of .004" (.1 mm).

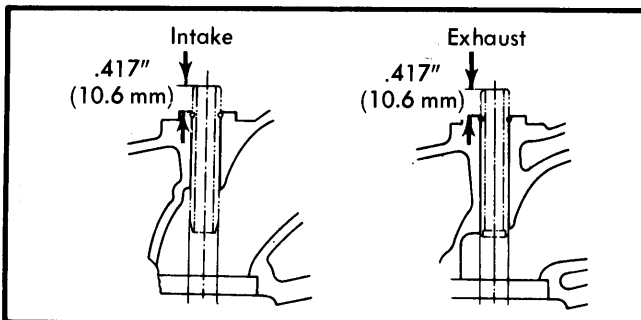

Fig. 4 Intake and Exhaust Valve Guides

VALVE SEAT INSERTS

1) Check valve seats for pitting at valve contact surface. Valve seat inserts of .02" (.5 mm) oversize are available if necessary. To remove old inserts, machine should be set so that boring cannot continue beyond bottom face of insert recess in cylinder head.

2) Machine cylinder head recess diameter in concentric circles to valve guide center so that insert will have correct fit. Heat cylinder head to 300-400°F (150-200°C) and install insert, making sure that it seats on bottom face of recess.

3) Valve seats should be cut or ground to correct face angle and seat width and to head diameter of valve to be installed.

VALVE SPRING INSTALLED HEIGHT

With valves closed, inner spring should have a height of 1.378" (35.0 mm) and outer spring should have a height of 1.575" (40.0 mm). See specification for pressure with valves opened or closed.

VALVE ADJUSTMENT

NOTE — Valves should be adjusted with engine at normal operating temperature. Cold specifications are provided for initial settings after assembly.

All Models — Turn engine until high point on No. 1 cam lobe points down. Adjust intake valve of No. 1 and No. 2 cylinder; exhaust valve of No. 3 and No. 4. Turn engine until high point on No. 1 cam lobe points up and adjust remaining valves.

Valve	Valve Adjustment Specifications	
	Hot	ⓁCold
Intake012" (.30 mm)008" (.21 mm)
Exhaust012" (.30 mm)009" (.23 mm)

Ⓛ — Use for initial settings only.

PISTONS, PINS & RINGS

PISTON & ROD ASSEMBLY

Removal — Remove connecting rod nuts and bearing caps. Push piston and rod assembly out top of cylinder, using care not to damage any bearing surface. Retain all components in proper order for reassembly.

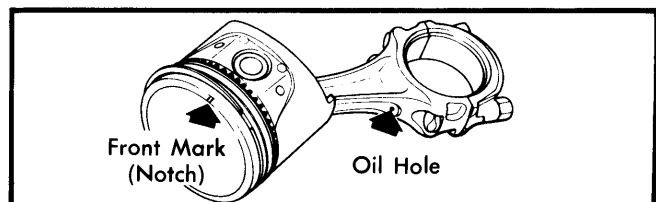

Fig. 5 Piston and Rod Assembly Installation Features

200SX, 510 & PICKUP 4-CYLINDER (Cont.)

Installation — Reassemble piston and rod so that oil hole in connecting rod is facing right side of engine and notch on top of piston is facing forward. Install connecting rod on original journal with rod and cap marks on same side. Tighten connecting rod nuts and check rod side play.

FITTING PISTONS

1) Measure cylinder bores for wear or taper at top, bottom and middle on thrust face and at 90° to thrust face. If excessive wear is found rebore cylinder and install oversize pistons. Oversize pistons are available as shown in table.

2) When boring cylinders, use cylinder order of 2-4-1-3 to prevent heat distortion. After honing cylinder to final fit, check piston fit using spring tension pull scale. A force of .4-3.3 lbs. (.2-1.5 kg) should be obtained extracting a .0016" (.04 mm) feeler gauge.

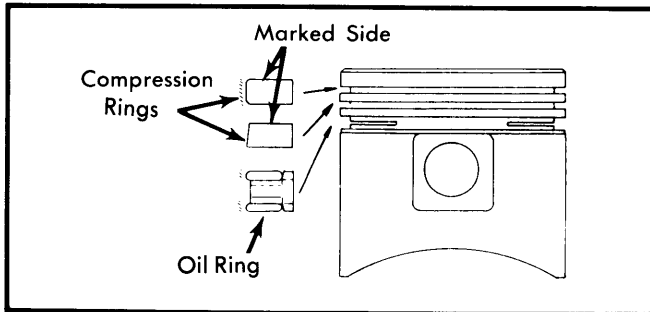

Fig. 6 Installation Order of Piston Rings

3) Measure piston ring end gap and side clearance and replace as necessary. Install rings on pistons with end gaps 180° apart and so no end gap is in line with thrust face. Install rings with top mark facing upward.

NOTE — If only piston ring is to be replaced, measure gap at bottom of bore. Oversize rings are available in .020" (.50 mm) and .040" (1.00 mm).

PISTON PINS

Pin must be a tight press fit in connecting rod, pressing force is from 1/2 to 1 1/2 tons. When pressing pin into connecting rod, oil pin and press in so oil jet of connecting rod large end is directed toward right side of cylinder block.

Piston Specifications	
Application In. (mm)	Piston Size In. (mm)
200SX, 510	
Standard	3.3459-3.3478 (84-985-85.035)
.020 (.50) OS	3.3648-3.3667 (85.465-85.515)
.040 (1.00) OS	3.3844-3.3864 (85-965-86.015)
Pickup	
Standard	3.4246-3.4266 (86.985-87.035)
.020 (.50) OS	3.4435-3.4455 (87.465-87.515)
.040 (1.00) OS	3.4632-3.4652 (87.965-88.015)

CRANKSHAFT MAIN & CONNECTING ROD BEARINGS

CRANKSHAFT

Removal — With engine removed from vehicle, remove cylinder head and oil pan. Remove flywheel and rear plate. Remove oil strainer, oil pump and drive spindle. Remove front cover, chain tensioner, chain slack side guide, and timing chain. Remove oil thrower, crankcase worm gear, and timing drive sprocket. Remove piston and rod assemblies. Remove main bearing caps using suitable puller (KV101041SO) to remove center and rear main bearing caps.

NOTE — Keep all main bearing caps in order to aid in reassembly. Remove rear oil seal, remove crankshaft.

Inspection — Check all crankshaft journals for scoring, wear or cracks. Taper and out-of-round on all journals must not exceed .001" (.025 mm). Check crankshaft for bend using dial indicator at center journal of crankshaft. If bend exceeds .002" (.05 mm), which is 1/2 of indicator reading, replace crankshaft. Check main driveshaft pilot bearing at rear of crankshaft for wear or damage and replace if necessary.

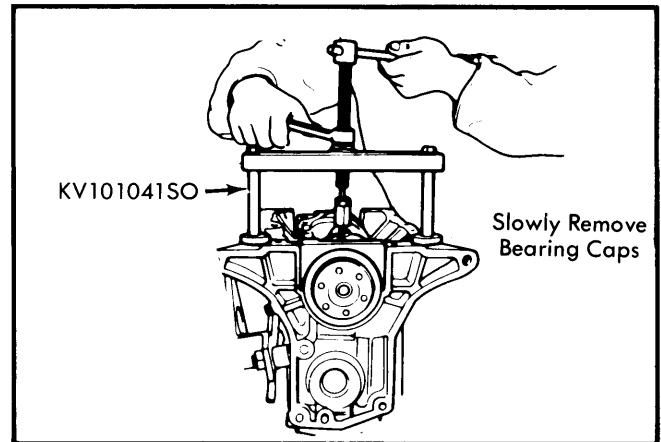

Fig. 7 Rear Main Bearing Cap Removal

Installation — 1) Install main bearing halves to engine block ensuring that all bearings are on correct journal. Journal No. 3 requires a thrust bearing. Bearing for No. 1 is the same as for No. 5 and bearing for No. 2 is the same as for No. 4. Upper and lower bearings are not interchangeable. Upper bearings have an oil groove.

2) Apply oil to main bearing surface and install crankshaft. Install main bearing caps with arrow pointing toward front of engine. Shift crankshaft toward front of engine, tighten main bearing caps, in two or three steps, starting at center bearing and working outwards. Ensure crankshaft rotates smoothly.

NOTE — Apply sealer to rear main bearing cap at point where cap contacts cylinder block.

3) Check crankshaft end play, and if not within specifications replace center thrust bearing. Install side seals in rear main bearing cap, after applying sealer to seals. Install rear oil seal. Install rear end plate and flywheel. Install piston and rod assemblies. Install remaining components in reverse of removal procedure

200SX, 510 & PICKUP 4-CYLINDER (Cont.)

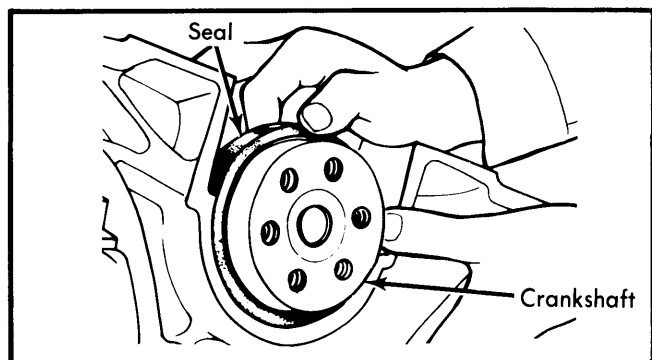

Fig. 8 Rear Oil Seal Removal

MAIN BEARINGS

1) Check all bearings for scoring or wear and replace if damage is found. Clean oil from crankshaft and place a strip of Plastigage on crankshaft journal. Install main bearing cap, with bearing installed, and tighten to 33-40 ft.lbs. (4.5-5.5 mkg).

NOTE — Plastigage should run parallel with crankshaft and not block oil hole. Do not turn crankshaft while Plastigage is inserted.

2) Remove cap and measure width of Plastigage at widest point using gauge provided. If clearance is not to specifications, replace bearings. Bearings are available in undersizes of .01" (.25 mm), .02" (.50 mm), .03" (.75 mm) and .04" (1.00 mm).

CONNECTING ROD BEARINGS

Check connecting rod bearings in same manner as main bearings using Plastigage. Tighten connecting rod caps to 33-40 ft. lbs. (4.5-5.5 mkg). Bearings are available in undersizes of .01" (.25 mm), .02" (.50 mm) and .03" (.75 mm). Check for clearance of .001-.002" (.025-.055 mm) when installing new bearings. Maximum wear limit for old bearings is .005" (.12 mm).

ENGINE OILING

Crankcase Capacity (With Filter)	
Application	Capacity
All Models	4.5 quarts

Oil Filter — Full-flow, disposable cartridge.

Oil Pressure — 50-60 psi. (3.5-4.2 kg/cm²) at 3000 rpm.

ENGINE OILING SYSTEM

Oil drawn from pan passes through screen to oil pump and is delivered to oil filter and to main oil gallery. Main oil gallery supplies oil to crankshaft main bearings and drilled passages in crankshaft. Oil sprayed from jet holes on connecting rods lubricates cylinders and piston pins. Oil from main gallery lubricates chain tensioner and timing chain. Center hole in crankshaft, center bearing feeds camshaft bearings on cylin-

der head. Valve rocker mechanism is lubricated through oil gallery in camshaft and through a small channel at base circle portion of each cam. Rocker arms and valves are lubricated through small holes in oil pipe.

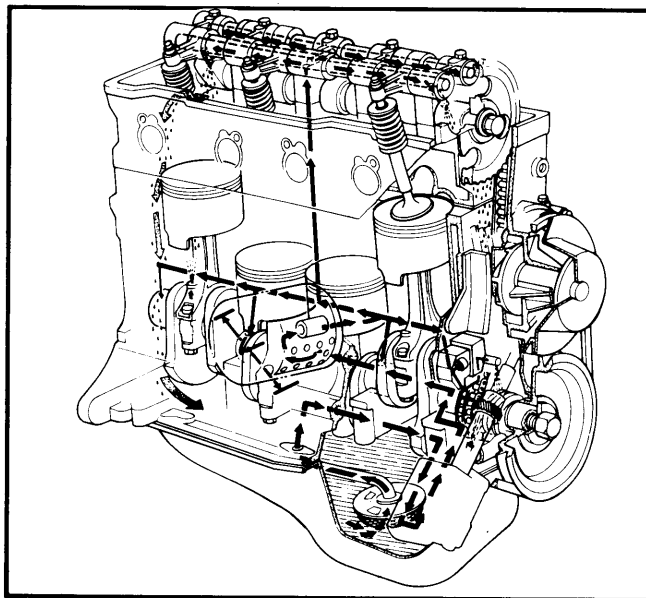

Fig. 9 Cutaway View of Engine Oiling System

OIL PUMP

Removal — Pump assembly is installed at bottom right of front cover and held in place by four bolts. Pump is driven by helical gear on crankshaft and in turn drives distributor shaft. With No. 1 cylinder at TDC on the compression stroke, remove retaining bolts and then remove oil pump and drive spindle assembly.

Inspection — Remove cover from oil pump body, remove gears. Wash parts with cleaning solvent, inspect for wear or damage. Make sure clearances are to specification. Pump is serviced as an assembly only. Replace pump if any part is worn or damaged.

Installation — Make sure that distributor rotor is in same position as it was before removal. Fill pump housing with oil and align punch mark on drive spindle with hole in pump. See Fig. 10. Using a new gasket, install oil pump and drive spindle assembly. Make sure that drive spindle tip securely fits distributor fitting hole. Tighten all bolts.

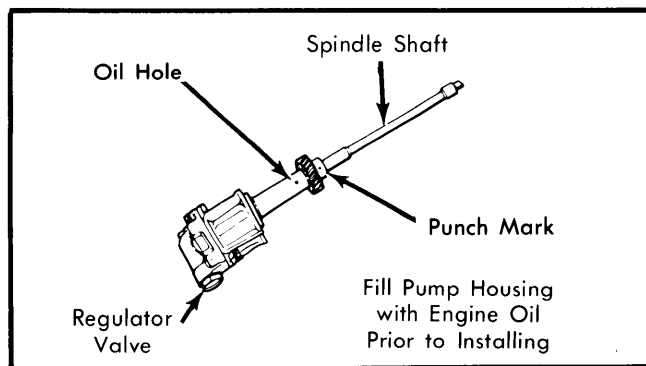

Fig. 10 Aligning Oil Pump Timing Marks

Datsun Engines

200SX, 510 & PICKUP 4-CYLINDER (Cont.)

Oil Pump Specifications

Application	① Clearance In. (mm)
Rotor Side Clearance (Rotor to Bottom Cover)	0.20 (0.0079)
Rotor Tip Clearance	0.20 (0.0079)
Outer Rotor to Body	0.5 (0.0197)

① — Wear limit specifications given.

Cooling System Capacity

Application	Capacity
510	9.0 quarts
200SX & Pickup	10.0 quarts

WATER PUMP

ENGINE COOLING

Thermostat — Opens at 180° F (82° C). Full open at 203° F (95° C).

Radiator Cap — 13 psi (.9 kg/cm²).

Centrifugal type pump with aluminum body. To remove drain cooling system and remove upper and lower radiator hoses, shroud, fan, belts and pulley. Remove pump attaching bolts and remove water pump.

ENGINE SPECIFICATIONS

GENERAL SPECIFICATIONS

Year	Displ.		Carburetor	HP at RPM	Torque (Ft. Lbs. at RPM)	Compr. Ratio	Bore		Stroke	
	cu. ins.	cc					in.	mm	in.	mm
1981 Pickup	133.5	2188	2-Bbl.	8.5-1	3.43	87	3.62	92
200SX	119.1	1952	Fuel Inj.①	8.5-1	3.35	85	3.39	86
510	119.1	1952	2-Bbl.	8.5-1	3.35	85	3.39	86

① — Electronic Fuel Injection

CRANKSHAFT MAIN & CONNECTING ROD BEARINGS

Engine	MAIN BEARINGS				CONNECTING ROD BEARINGS		
	Journal Diam. In. (mm)	Clearance In. (mm)	Thrust Bearing	Crankshaft End Play In. (mm)	Journal Diam. In. (mm)	Clearance In. (mm)	Side Play In. (mm)
1952 cc & 2188 cc	2.1631-2.1636 (54.942-54.955)	.0008-.0024 (.020-.062)	No. 3	.002-.007 (.05-.18)	1.9670-1.9675 (49.961-49.974)	.001-.002 (.025-.055)	.0079-.0118 (.20-.30)

VALVES

Engine & Valve	Head Diam. In. (mm)	Face Angle	Seat Angle	Seat Width In. (mm)	Stem Diameter In. (mm)	Stem Clearance In. (mm)	Valve Lift In. (mm)
1952 cc & 2188 cc Intake	1.654-1.661 (42.0-42.2)	45°	45°	.071-.094 (1.8-2.4)	.3136-.3142 (7.965-7.980)	.0008-.0021 (.020-.053)
Exhaust	1.496-1.504 (38.0-38.2)	45°	45°	.059-.075 (1.5-1.9)	.3128-.3134 (7.945-7.960)	.0016-.0029 (.040-.073)

200SX, 510 & PICKUP 4-CYLINDER (Cont.)

ENGINE SPECIFICATIONS (Cont.)

PISTONS, PINS, RINGS						
Engine	PISTONS	PINS		RINGS		
	Clearance In. (mm)	Piston Fit In. (mm)	⓪Rod Fit In. (mm)	Rings	End Gap In. (mm)	Side Clearance In. (mm)
1952 cc & 2188 cc	.0010-.0018 (.025-.045)	.0002-.0005 (.006-.013)	.0006-.0014 (.015-.035)	No. 1	.010-.016 (.25-.40)	.0016-.0029 (.040-.073)
				No. 2	.006-.012 (.15-.30)	.0012-.0025 (.030-.063)
				Oil	.012-.035 (.30-.90)

⓪ — Interference fit.

VALVE SPRINGS			
Engine	Free Length In. (mm)	PRESSURE Lbs. @ In. (kg @ mm)	
		Valve Closed	Valve Open
1952 cc & 2188 cc	1.736 (44.10)	24.3@1.378 (11.0@35.0)
		Outer	1.959 (49.77)

CAMSHAFT			
Engine	Journal Diam. In. (mm)	Clearance In. (mm)	Lobe Lift In. (mm)
1952 cc & 2188 cc	1.2967-1.2974 (32.935-32.955)	.0018-.0035 (.045-.090)	.008" (0.2)

TIGHTENING SPECIFICATIONS	
Application	Ft. Lbs. (N·m)
Cylinder Head	51-58 (69-79)
Connecting Rods	33-40 (45-54)
Flywheel	101-116 (137-158)
Main Bearings	33-40 (45-54)
Camshaft Sprocket	87-116 (118-158)
Crankshaft Pulley	87-116 (118-158)
Manifolds	12-15 (16-20)
Rocker Arm Nuts	12-16 (16-22)
Application	INCH Lbs. (N·m)
Front Cover	
6 mm Bolts	35-86 (4-10)
8 mm Bolts	84-144 (10-16)