

320i 4-CYLINDER

ENGINE CODING

ENGINE IDENTIFICATION

Engine identification number is on engine block at left hand side above starter motor.

ENGINE & CYLINDER HEAD

NOTE – Transmission must be removed prior to removing engine.

MANUAL TRANSMISSION

Removal – 1) Remove all mounting bolts accessible from above. Remove exhaust support and exhaust pipe at manifold. Tighten compressing strap (261012) around front rubber coupling until bolts attaching rubber coupling to transmission output flange can be removed.

2) Detach center bearing bracket from body after removing heat shield to gain access. Pull down on propeller shaft at center bearing to disengage shaft from transmission flange. Remove speedometer cable and disconnect back-up light switch.

3) Remove center console from transmission, remove circlip and washer, pull out selector rod. Remove clutch slave cylinder, support transmission with jack or stand. Remove crossmember and remaining transmission mounting bolts. Remove transmission towards rear of vehicle.

Installation – To install, reverse removal procedure and note the following: When installing propeller shaft, push center bearing bracket forward .08" (2 mm) to preload center bearing and tighten nuts.

AUTOMATIC TRANSMISSION

Removal – 1) Remove accelerator cable. Remove all mounting bolts accessible from above. Remove oil filler neck and drain oil. Remove exhaust support and exhaust pipe at manifold. Remove speedometer drive cable. Remove bolts from transmission output flange and detach coupling.

2) Detach center bearing bracket from body after removing heat shield to gain access. Pull down on propeller shaft at center bearing to disengage shaft from transmission flange.

3) Remove drive plate bolts from torque converter. Remove transmission oil cooler lines. Support transmission with jack or stand, then remove crossmember at body. Remove remaining transmission mounting bolts. Remove transmission and torque converter from vehicle.

Installation – To install, reverse removal procedure, ensuring that torque converter is properly positioned on drive plate. When installing propeller shaft, push center bearing bracket forward .08" (2 mm) to preload center bearing and tighten nuts.

ENGINE

Removal – 1) Remove transmission. Drain cooling system and disconnect hoses. Remove fan shroud and radiator. Disconnect and remove battery. Remove intake cowl and disconnect wires and fuel lines to injection system. Detach and suspend A/C compressor (if equipped). DO NOT disconnect hoses.

2) Disconnect wires, fuel and coolant lines and control cables between engine and chassis. Install engine sling (110000) to eyes at front and rear of engine. Detach left engine mount and upper engine damper. Detach right engine mount and lift engine from vehicle.

Installation – To install, reverse removal procedure and note the following: When filling with coolant, set heater control to "warm" and fill radiator slowly. Bleed system after engine is warm by turning cap to catch 1, then remove cap and fill radiator.

CYLINDER HEAD

Removal – 1) Pull off breather tube, then pull hose with connector out of tube. Dismantle air cleaner assembly. Disconnect ground lead from battery. Drain cooling system. Disconnect accelerator cable. Remove cylinder head cover (rocker arm cover).

2) Remove lines to injection valves (mark for reassembly). Remove pressure converter hoses, water hoses at cylinder head and crankcase hoses at throttle housing and thermo valve (marking for reassembly). Remove upper timing case cover, disconnect plug connectors and ignition coil wires. Remove distributor cap and pull plugs off cold start valve, auxiliary air valve and timing valve. Disconnect oil pressure switch wire.

3) Set piston of No. 1 cylinder at TDC, (rotor points to notch in distributor housing, indicator points to notch in pulley). Remove timing chain tensioner and timing chain sprocket. Remove exhaust pipe at manifold and holder to transmission. Remove cylinder head bolts in reverse sequence of tightening, remove cylinder head.

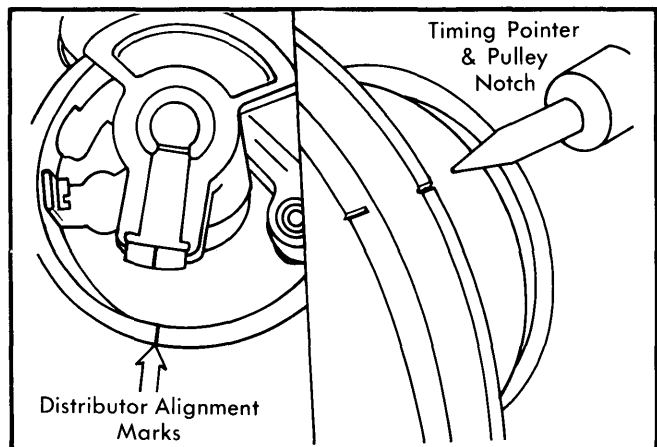

Fig. 1 Correct Procedure to Set No. 1 Piston at TDC

Installation – 1) Measure dowel (installation guide) projection above cylinder head mounting surface. See Fig. 3. Maximum projection should not exceed .197" (5 mm). Ensure that there is no oil in cylinder head bolt blind holes or head bolts will not be able to exert required holding force on head.

2) Replace cylinder head and components in reverse order of removal procedure. Tighten head bolts in sequence. See Fig. 2. Start engine and run until normal operating temperature is reached. Allow to cool to about 95° F (35° C) and tighten to final torque.

320i 4-CYLINDER (Cont.)

NOTE — Head bolts should be re-checked for final torque after 600 miles. Always check torque with engine cool.

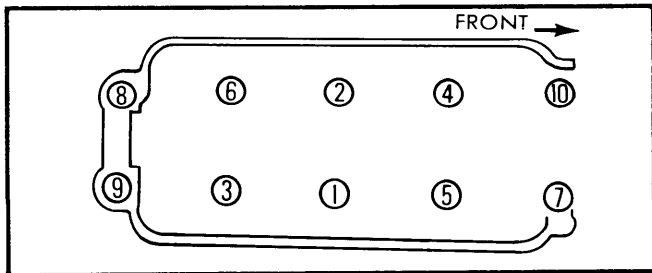

Fig. 2 Tighten Cylinder Head in Sequence Shown (Remove in Reverse Sequence)

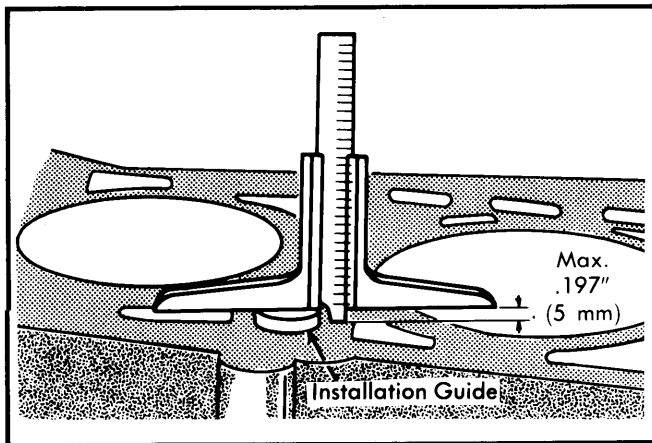

Fig. 3 Measure Dowel Projection as Shown

CAMSHAFT

CAMSHAFT

Removal — 1) With cylinder head removed, loosen clamping screw and pull out distributor. Attach head assembly to a suitable holding tool (No. 11 1 040). Remove oil line and cold start valve.

2) Adjust valve clearance to maximum possible. Attach a suitable compression frame to preload the rocker assembly. Check end play between guide plate and camshaft. Remove guide plate and carefully withdraw camshaft.

Installation — 1) When replacing camshaft, note the following: After guide plate has been installed, it must be possible to easily rotate the camshaft. Make sure that notch in flange aligns with cast tab on cylinder head. Adjust valve clearances, note position of oil pipe sealing rings.

2) When replacing distributor, turn rotor counterclockwise by about 1.4" (35 mm) from notch in distributor housing, bring distributor drive into mesh with camshaft drive. Ensure vacuum advance has been located in original position. Adjust ignition timing.

ENGINE FRONT COVER

Upper Cover — Remove cylinder head cover and detach EGR check valve pipe from exhaust manifold. Take out bolts (8) at-

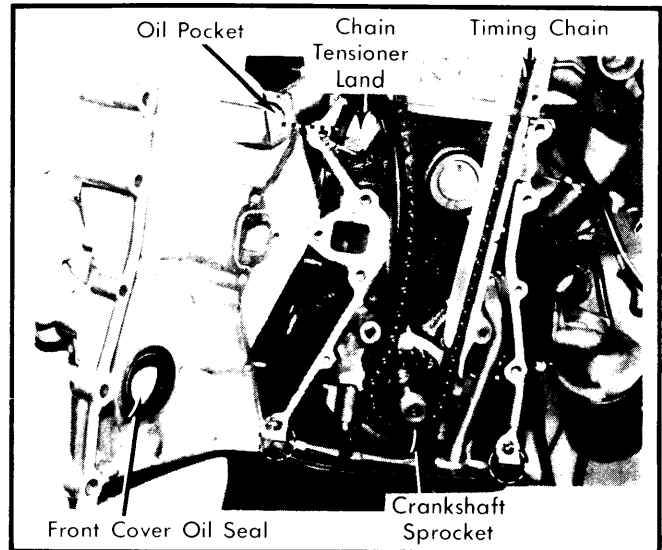

Fig. 4 Timing Chain with Lower Case and Cover

taching cover to head and block. Remove, clean and inspect cover. To install, use new gasket and apply suitable sealant to mating surfaces. Place cover in position and insert all bolts, tightening lower bolts at block slightly. Tighten bolts evenly to specifications starting at lower head and finishing with bolts fastening cover to block.

Lower Timing Case Cover — 1) Disconnect battery ground cable and remove water pump. Remove upper timing case cover and chain tensioner piston. Remove alternator with bracket and tensioning bar. Remove air pump and bracket with tensioning bar.

2) Take off front pulley and remove bolts on timing case cover and front of oil pan. Carefully separate oil pan gasket from timing case cover with knife blade and remove lower cover.

3) To install, apply sealant and new gaskets. Ensure that chain tensioner take-up land is in oil pocket and reverse removal procedures.

TIMING CHAIN REPLACEMENT

Removal & Installation — 1) Remove distributor cap, set piston of No. 1 cylinder at TDC. Remove upper and lower timing case covers. Remove sprocket. Remove circlip and unscrew pivot pin until guide rail rests on cylinder head gasket. Remove timing chain from sprocket and crankshaft. Remove guide rail by pulling down and swinging to the right.

2) If timing chain sprockets need replacing, remove timing chain, oil pan and oil pump sprocket. Remove Woodruff key and oil pump drive chain. Using puller (11 2 000), remove sprocket. Heat sprocket and install. To complete installation, reverse removal procedure.

VALVE TIMING

Rotate engine to TDC of No. 1 piston. Position camshaft so that timing mark on camshaft flange is straight up and locating pin hole is straight down. Without moving crankshaft or camshaft, install camshaft sprocket so that it engages locating pin hole in camshaft flange.

320i 4-CYLINDER (Cont.)

TIMING CHAIN TENSIONER SERVICE

1) Use caution due to high spring pressure and unscrew tensioner plug. Remove piston and spring. Press piston out of sleeve, remove ball bearing and perforated disc, and clean all parts thoroughly. Reassemble parts in order, ensuring that perforated disc does not block bleed slots.

2) Install piston in tensioner body. Place spring with tapered end facing tensioner plug. Screw plug slightly into tensioner body. Fill oil pocket with engine oil and move tensioner rail back and forth until oil comes out around plug threads. Tighten tensioner plug.

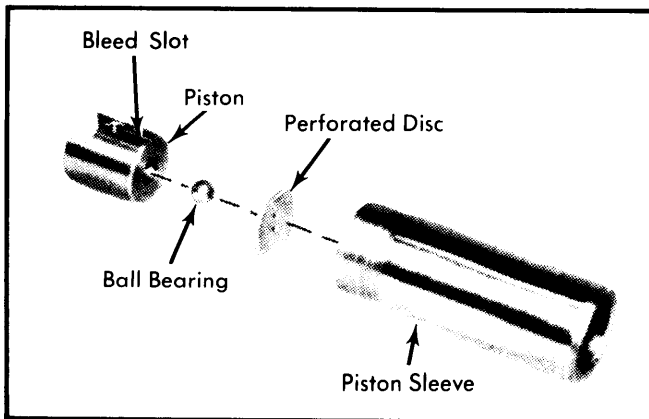

Fig. 5 Exploded View of Chain Tensioner Piston Assembly

VALVES

VALVE ARRANGEMENT

Right Side — All exhaust.

Left Side — All intake.

ROCKER ARM ASSEMBLY

Removal — With camshaft removed, push back thrust ring and rocker arm so rocker shaft circlip may be removed. Remove distributor mounting flange. Drive out rocker arms from rear using drift (11 3 040). Retain all springs, washers, rocker arms and thrust rings in proper order for assembly.

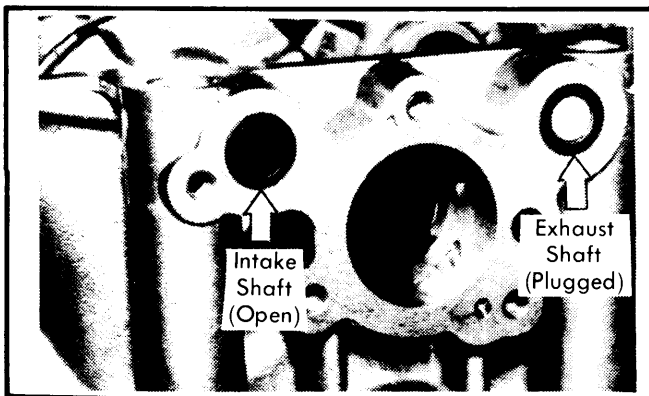

Fig. 6 Rear View of Head Showing Plug in Exhaust Rocker Shaft

Installation — Install all parts in original location. Replace worn rocker arms and shafts, and any rocker arms with loose

contact pads. When installing rocker arm shafts, notches must be aligned to allow cylinder head bolts to fit in openings. Install circlip and ensure that plug in exhaust side rocker shaft is tight.

NOTE — Rocker arm shaft on intake side is open. Exhaust rocker shaft is plugged.

VALVE SPRING SERVICE

Compress spring and remove keepers. Remove spring and retainer. Check spring free length and pressure and replace as required. Install springs with tight winding (painted mark) facing cylinder head. Install retainers and keepers.

VALVE GUIDE SERVICE

1) Check valve guide for wear. If replacement is necessary, press out guide toward combustion chamber. Measure guide bore in cylinder head. If bore exceeds .5512" (14 mm), ream head and install oversize guide.

2) Heat cylinder head to 428-482°F (220-250°C) and press in new guide from top side until tapered groove end protrudes .591" (15 mm) for standard guide, or .531" (13.5 mm) for modified guide. Ream guide to obtain specified clearance. Valve guides are available in the following sizes:

Valve Guide Sizes	
Application	Guide O.D. In. (mm)
Standard5532 (14.05)
1st Oversize5551 (14.10)
2nd Oversize5590 (14.20)
3rd Oversize5630 (14.30)
Standard Length	2.047 (52.0)
Modified Length	1.988 (50.5)

VALVE SEAT SERVICE

Refer to illustration and note minimum valve seat and valve head thicknesses. If either specification is not met, replace necessary component. When replacing valve seat, remove old seat by turning out with suitable cutting tool. Drill out bore to appropriate oversize: note valve seat oversize to be used and rebores head allowing for shrink-fit of replacement seat. When installing new seat, heat head to approximately 392°F (200°C) and chill valve seat to approximately -94°F (-70°C). Replacement seats are available in the following oversizes:

Replacement Valve Seat Rings	
Application	Measurement In. (mm)
Intake	
1st Oversize	1.864 (47.35)
2nd Oversize	1.872 (47.55)
Exhaust	
1st Oversize	1.589 (40.35)
2nd Oversize	1.596 (40.55)

320i 4-CYLINDER (Cont.)

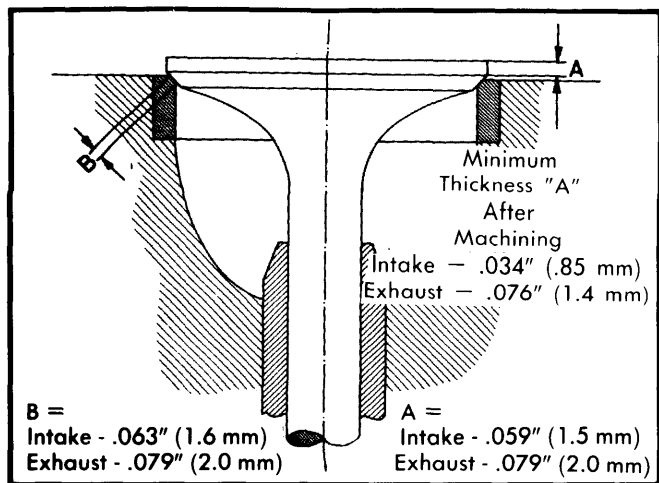

Fig. 7 Checking Valve Head and Seat Thickness

VALVE CLEARANCE ADJUSTMENT

Adjust valves in firing order sequence (1-3-4-2) with specific cylinder at TDC of compression stroke. Using a feeler gauge between rocker eccentric and valve stem, set clearance to .008-.010" (20-25 mm) with engine hot, or to .006-.008" (.15-.20 mm) with engine cold. Loosen nut of rocker excentric, insert a rod in eccentric hole and rotate until proper clearance is obtained. See Fig. 8.

NOTE - Never measure or adjust valve clearance between camshaft and rocker arm pad.

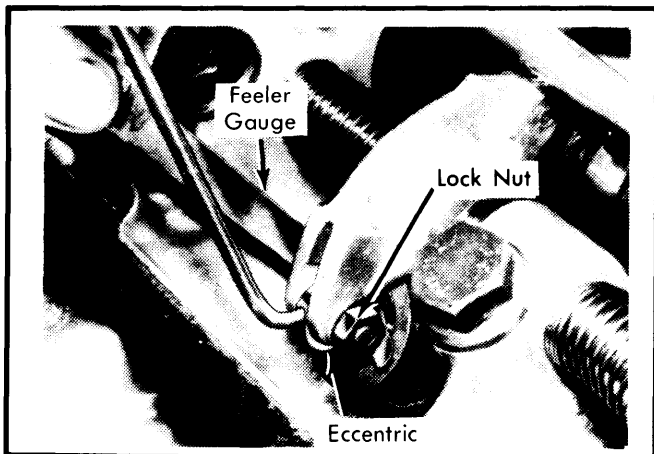

Fig. 8 Valve Clearance Adjustment

PISTONS, PINS & RINGS

OIL PAN

With engine installed, remove bolts securing steering to front axle carrier, move steering out of way. Drain oil, remove bolts securing oil pan, swing pan down. Turn crankshaft and remove oil pan. Coat crankcase ends where timing cover and rear main bearing cover join crankcase with sealing compound before reassembly.

PISTON & ROD ASSEMBLY

Removal - After removing oil pan and cylinder head, rotate crankshaft to BDC of piston and rod assembly to be removed. Unscrew connecting rod cap nuts and push assembly out top of engine. Replace worn or damaged parts as necessary, according to appropriate service procedure indicated in this article.

Installation - Place rings on piston with marking "TOP" facing upward and ring end gaps 120° apart. Install piston with arrow facing forward and oil hole in wrist pin end of connecting rod facing timing chain. Ensure connecting rod and bearing cap numbers match, with No. 1 rod nearest the timing chain.

CONNECTING ROD BUSHING

Wrist pins and pistons are matched to each other and must be replaced together. To remove piston pin from assembly, remove circlip and push out wrist pin. In event of excess clearance, new wrist pin bushing may be pressed in rod. Bushing seam should be at 90° to oil bore. Drill and deburr oil holes, then ream bushing so that pin is a light push fit through connecting rod.

FITTING PISTONS

Piston crowns are marked with arrow for direction of installation and a "+", "-", or no sign to show weight classification. All pistons should have same weight mark. Measure piston and cylinder diameter to determine clearance (see specifications). Measure piston diameter at 90° to wrist pin bore near bottom of piston skirt, see following table for distance from bottom of piston.

Piston Measuring Location	
Piston	⓪In. (mm)
Mahle630 (16.0)
KS959 (24.35)
⓪ - Distance from bottom of piston.	

Piston Sizes	
Application (Grade)	Diameter In. (mm)
Standard	3.5027 (88.97)
Intermediate	3.5059 (89.05)
No. 1 Oversize	3.5126 (89.22)
No. 2 Oversize	3.5224 (89.47)

CRANKSHAFT MAIN & CONNECTING ROD BEARINGS

MAIN BEARING SERVICE

Plastigage method is used to determine connecting rod and main bearing journal clearances. Standard or undersize crankshafts are marked red or blue. Color coded inserts must agree with crankshaft color code as illustrated. The following tables show color code and undersizes available:

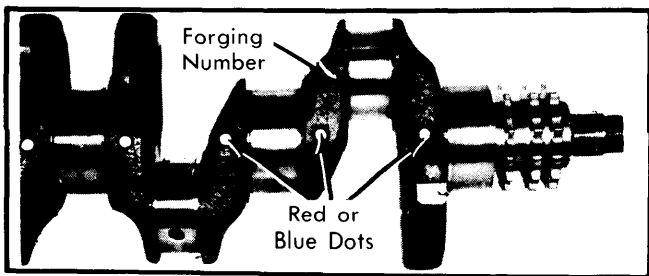

Fig. 9 View Showing Original Crankshaft Marks

320i 4-CYLINDER (Cont.)

Main Bearing Journal

Application	In. (mm)
Original	2.165 (55.0)
1st Stage	2.156 (54.75)
2nd Stage	2.146 (54.50)
3rd Stage	2.136 (54.25)

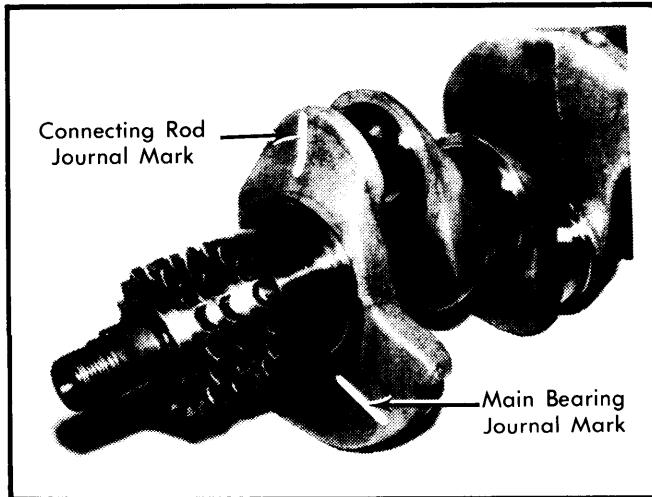

Fig. 10 View Showing Undersize Crankshaft Marking

Connecting Rod Journal

Application	In. (mm)
Original	1.889 (48.0)
1st Stage	1.879 (47.75)
2nd Stage	1.870 (47.50)
3rd Stage	1.860 (47.25)

CAUTION — Crankshaft should only be factory ground

THRUST BEARING ALIGNMENT

Attach a dial indicator to crankcase with shaft touching flywheel. Move flywheel in and out to determine endplay of crankshaft. If endplay is excessive, replace center main bearing inserts.

REAR MAIN BEARING OIL SEAL SERVICE

With flywheel removed, unscrew six attaching bolts from rear crankshaft seal holder. Carefully run a knife blade between seal holder and oil pan gasket to break seal. Remove seal holder and press out old seal, press in new seal. Coat oil pan gasket at either side with sealing compound and replace seal holder.

FRONT COVER OIL SEAL

Seal may be replaced with engine in car. Remove radiator and fan belt. Lock flywheel with suitable tool (11 2 100), remove front pulley nut and take off pulley. Remove seal and inspect pulley for wear. Pack lips of new radial seal with grease and install with tools (11 1 271 and 11 1 273). Position Woodruff key correctly and install pulley.

ENGINE OILING

ENGINE OILING SYSTEM

A chain driven rotor type oil pump pressure feeds oil to a full-flow oil filter. From oil filter, oil is circulated through passages to all moving parts of the engine.

Crankcase Capacity — 4.25 qts.

Oil Filter — Full-Flow

Oil Pressure — 57 psi (4.0 kg/cm²) at 4000 RPM.

Pressure Regulator Valve — Non-adjustable

OIL PUMP

- 1) Remove oil pan and oil pump sprocket. Remove bolts attaching pump pick-up. Remove two bolts mounting pump to crankcase and lift out pump.
- 2) Unscrew union and remove spring and plunger from pump body. Remove pick-up tube and cover from pump body.
- 3) Measure clearance between outer rotor-to-pump body, rotor-to-rotor and rotor face-to-pump body flange (see specifications).
- 4) Using suitable puller, remove drive flange from rotor shaft. Press drive flange on new rotor shaft to a distance of 1.68" (42.7 mm) between flange and rotor face. See Fig. 11.

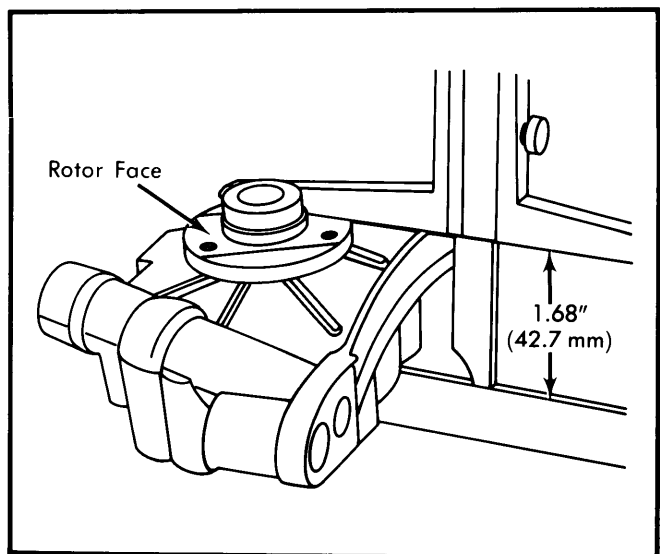

Fig. 11 Measuring Distance Between Flange and Rotor Face

Oil Pump Specifications

Application	Measurement In. (mm)
Rotor-to-Pump Body006-.011 (.150-.275)
Inner-to-Outer Rotor0047-.0079 (.12-.20)
Cover-to-Rotor0014-.0037 (.035-.095)
Pressure Relief Spring	
Free Length	2.677 (68.0)
Installed Length	2.618 (66.5)

320i 4-CYLINDER (Cont.)

5) To install, reverse removal procedure noting that normal length (colored red) and extra long (colored green) chains are available. Further adjustment is possible by using shims between pump body and block. Oil hole in shims must line up with oil hole in pump. Chain tension is correct if chain gives under slight thumb pressure.

2) Using a suitable puller, remove fan hub from impeller shaft. Extract circlip and spacer ring from front of pump.

3) Press impeller off shaft and pump bearing out of housing. Drive friction seal out of housing and lift out cover ring.

ENGINE COOLING

Thermostat — Opens at 176°F (80°C).

Cooling System Capacity — 7.4 qts.

4) Replace any worn or damaged parts. Using suitable tool, press impeller onto shaft until there is clearance of .039-.047" (1.0-1.2 mm) between impeller and pump face.

WATER PUMP

1) Loosen alternator bracket. Remove fan and drive belt. Loosen hose clamps and remove water pump.

5) Press fan hub onto shaft until shaft extends .118-.138" (3.0-3.5 mm) beyond hub face. Install pump and fan, assuring that lockplates are crimped fan bolts.

ENGINE SPECIFICATIONS

GENERAL SPECIFICATIONS										
Year	Displ.		Carburetor	HP at RPM	Torque (Ft. Lbs. at RPM)	Compr. Ratio	Bore		Stroke	
	cu. ins.	cc					in.	mm	in.	mm
1981	107.7	1766	Fuel Inj.	102 @ 5800	100 @ 4500	8.8:1	3.504	89	2.795	71

VALVES							
Engine & Valve	Head Diam. In. (mm)	Face Angle	Seat Angle	Seat Width In. (mm)	Stem Diameter In. (mm)	Stem Clearance In. (mm)	Valve Lift In. (mm)
1766 cc Intake	1.805 (45.84)	45.5°	45°	.059-.083 (1.50-2.10)	.3134-.3139 (7.960-7.975)	.0010-.0020 (.025-.055)
Exhaust	1.490 (37.84)	45.5°	45°	.061-.081 (1.55-2.05)	.3129-.3134 (7.945-7.960)	.0015-.0030 (.040-.070)

VALVE SPRINGS			
Engine	Free Length In. (mm) ①	PRESSURE Lbs. @ In. (kg @ mm)	
		Valve Closed	Valve Open
1766 cc	1.712 (43.5)	64@1.48 (29@37.6)	154@1.12 (70@28.5)

VALVE TIMING				
Engine	INTAKE		EXHAUST	
	Open (BTDC)	Close (ABDC)	Open (BBDC)	Close (ATDC)
1766 cc	4°	52°	52°	4°

① — May be 1.811" (46.0 mm) for some springs.

BMW Engines

320i 4-CYLINDER (Cont.) ENGINE SPECIFICATIONS (Cont.)

PISTONS, PINS, RINGS						
Engine	PISTONS	PINS		RINGS		
	Clearance In. (mm)	Piston Fit In. (mm)	Rod Fit In. (mm)	Rings	End Gap In. (mm)	Side Clearance In. (mm)
1766 cc	.0018 (.045)	①.00008-.00024 (.002-.006)	.0001-.0004 (.003-.010)	No.1	.012-.020 (.30-.50)	②.0024-.0036 (.06-.092)
				No.2	.008-.016 (.20-.40)	②.0016-.0028 (.040-.072)
				No.3	.010-.016 (.25-.40)	②.0012-.0024 (.030-.062)

- ① - Mahle Pistons - .0004-.0020" (.001-.005 mm)
- ② - KS Pistons Shown. Mahle Piston Ring No. 1 - same as KS. Mahle Piston Ring No. 2 - .0012-.0024" (.030-.062 mm). Mahle Piston Ring No. 3 - .0008-.0020" (.020-.052 mm).

CRANKSHAFT MAIN & CONNECTING ROD BEARINGS							
Engine	MAIN BEARINGS				CONNECTING ROD BEARINGS		
	Journal Diam. In. (mm)	Clearance In. (mm)	Thrust Bearing	Crankshaft End Play In. (mm)	Journal Diam. In. (mm)	Clearance In. (mm)	Side Play In. (mm)
1766 cc Red	2.165 (55.0)	.0012-.0027 (.030-.070)	Center	.0033-.0068 (.085-.174)	1.8898 (48.0)	.0012-.0027 (.030-.070)
Blue	2.165 (55.0)	.0012-.0026 (.030-.068)	Center		1.8898 (48.0)	.0012-.0026 (.030-.068)

CAMSHAFT			
Engine	Journal Diam. In. (mm)	Clearance ① In. (mm)	Lobe Lift In. (mm)
1766 cc No. 1	1.3769-1.3795 (34.975-35.041)	.0013-.0029 (.034-.074)	.274-.280 (6.95-7.11)
No. 2	1.6525-1.6551 (41.975-42.041)	.0013-.0029 (.034-.074)	.274-.280 (6.95-7.11)
No. 3	1.6919-1.6945 (42.975-43.041)	.0013-.0029 (.034-.074)	.274-.280 (6.95-7.11)

- ① - End play is .0008-.005" (.020-.127 mm).

TIGHTENING SPECIFICATIONS	
Application	Ft. Lbs. (N·m)
Cylinder Head Studs①	
Step 1	25-32 (33-44)
Step 2	49-52 (67-71)
Step 3	56-59 (77-81)
Main Bearing Caps	42-45 (57-62)
Connecting Rod Bolts	38-41 (51-56)
Flywheel-to-Crankshaft②	72-83 (98-113)
Crankshaft Pulley	101-108 (140-150)
	INCH Lbs. (N·m)
Rocker Arm Lock Bolts	84-96 (10-11)
Camshaft Oiler (Hollow Bolt)	96-108 (11-13)
Timing Cover	84-96 (10-11)
① - With engine at maximum of 95°F (35°C).	
② - Coat bolts with Loctite.	