

TOYOTA INTEGRAL CARRIER

Celica (Exc. Limited Slip)
Corona (Exc. Limited Slip)
Supra (Exc. Limited Slip)

DESCRIPTION

Final drive assembly has hypoid type ring and pinion gear and removable rear cover. Differential carrier is retained in the sides of the housing by retaining plates and is supported by tapered roller bearings. Side bearing preload is adjusted by turning adjusting nuts on each side of carrier. Drive pinion gear is supported by roller bearings and preload is maintained by a non-collapsible spacer between the bearings.

AXLE RATIO & IDENTIFICATION

The integral carrier is identifiable by the inspection cover on the rear of the carrier housing. To determine axle ratio, divide number of ring gear teeth by number of pinion gear teeth.

REMOVAL & INSTALLATION

AXLE SHAFTS

NOTE — Removal procedures not available for Supra.

Removal — Raise and support vehicle. Remove tire and wheel. Working through hole in axle flange, remove bolts holding bearing retainer to axle housing flange. Using slide hammer, remove shaft from housing using care not to damage axle seal. If both axles are to be removed, be sure to index each for reinstallation in original position. If axle housing seal is being replaced, coat sealing lip with grease before installing.

Installation — To install, reverse removal procedure.

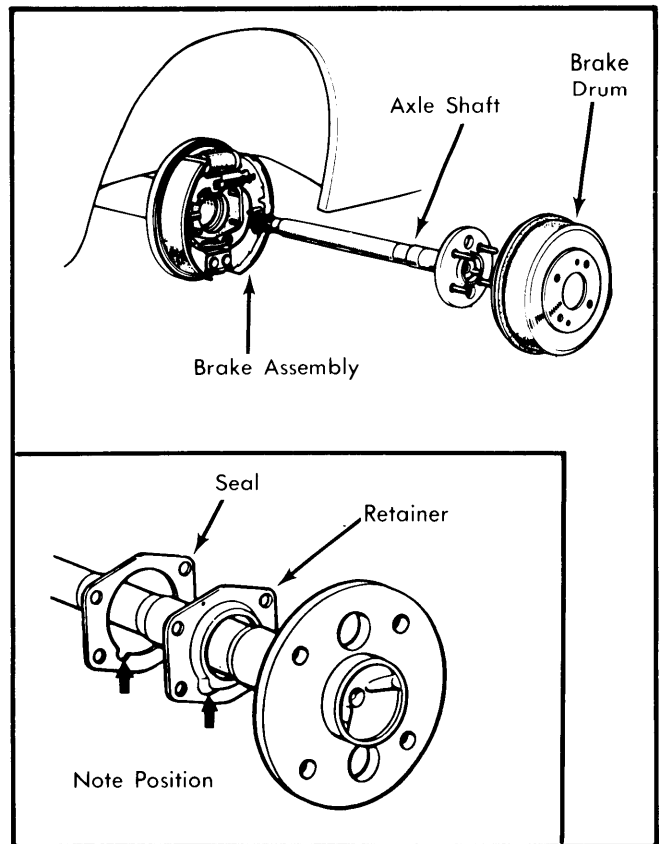

Fig. 2 Exploded View of Rear Axle Assembly (Celica & Corona Shown)

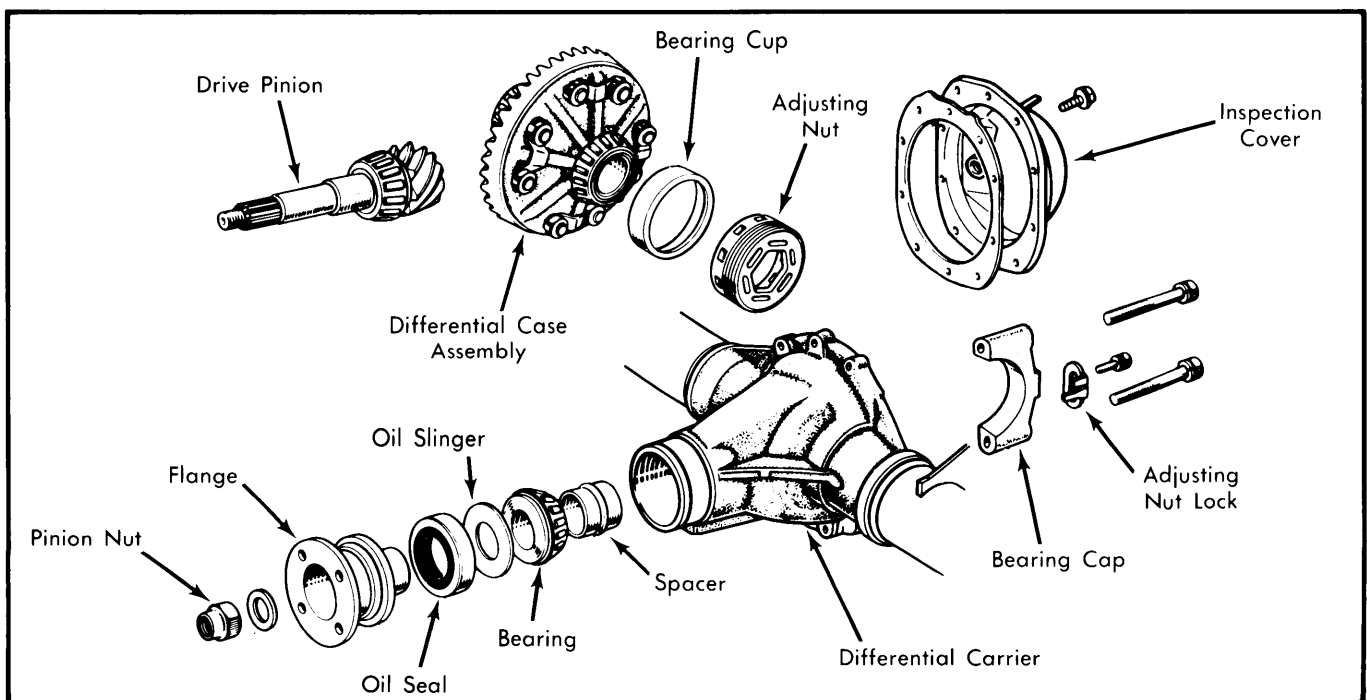

Fig. 1 Exploded View of Toyota Integral Carrier Differential

TOYOTA INTEGRAL CARRIER (Cont.)

AXLE BEARINGS

Removal – To remove bearing, grind part way through bearing retainer ring using caution not to nick axle shaft. Cut remaining portion of retaining ring using a cold chisel. Remove split retaining ring and press bearing off shaft. Remove spacer from shaft.

Installation – 1) To install, place spacer and bearing onto shaft and press into place. Heat new retaining ring to about 300°F (150°C) and press into place.

NOTE – The retaining ring will show a faint yellow color when heated to proper temperature.

2) Install gaskets on shaft so they will be between bearing retainer and backing plate. Install axle shaft, check to ensure gaskets and retainer are installed with notch pointed in direction shown in illustration. Tighten bolts.

PINION SEAL REPLACEMENT
(ON VEHICLE)

Removal – 1) Remove drain plug and drain carrier lubricant. Reinstall plug and index companion flange to propeller shaft. Remove propeller shaft, then set parking brake. Unstake pinion nut, install flange holder (SST 09330-00020) and remove pinion nut.

2) Install flange remover (SST 09557-22022) and remove flange. Remove oil seal with puller (SST 09308-10010), then remove oil slinger. Remove bearing with bearing puller (SST 09556-22010). Remove bearing spacer.

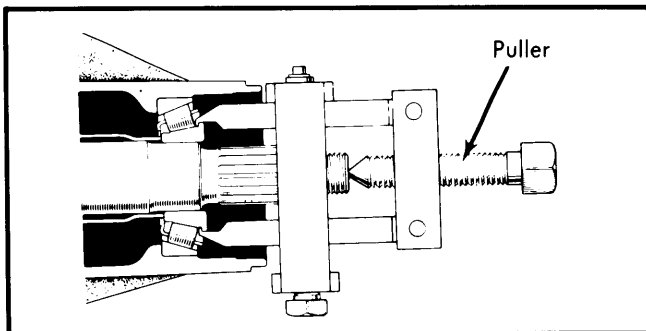

Fig. 3 Removing Drive Pinion Gear Front Bearing

Installation – 1) Install new bearing spacer. Install bearing and oil slinger. Apply grease to seal lip and drive seal into carrier. Oil seal drive-in depth is .08" (2 mm). Install pinion flange, then install new pinion nut. Rotate pinion in both directions to seat bearing, then measure preload. Tighten pinion nut to 80 ft. lbs. (11 mkg).

2) Set parking brake and install INCH lb. torque wrench. Measure the preload within range of the backlash between drive pinion and ring gear. Preload for a new bearing should be 8.7-13.9 INCH lbs. (10-16 cmkg) or 4.3-6.9 INCH lbs. (5-8 cmkg) for a reused bearing.

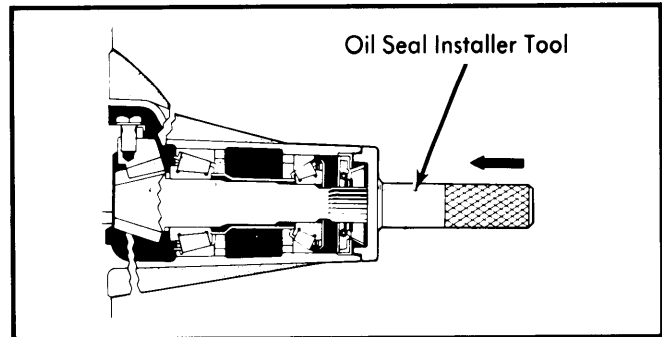

Fig. 4 Installing Oil Seal

3) If preload is greater than specification, replace bearing spacer. If preload is less than specification, retighten nut 10 ft. lbs. (1.3 mkg) at a time until specified preload is obtained. After adjustment, stake pinion nut, then align companion flange and propeller shaft index marks and install propeller shaft.

NOTE – If maximum torque of 173 ft. lbs. (24 mkg) is exceeded, replace bearing spacer and repeat procedure. DO NOT back off pinion nut to reduce preload.

DIFFERENTIAL CARRIER

NOTE – Differential carrier is integral part of axle housing and can not be removed as an assembly.

OVERHAUL

DISASSEMBLY

Differential Case – 1) Remove axle shafts as previously described and raise and support vehicle. Drain differential lubricant. Remove propeller shaft, lateral control rod and brake line (at top of differential housing). Remove companion flange, oil seal, slinger, bearing and spacer, then remove rear inspection cover.

2) Punch alignment marks on bearing caps and differential carrier. Remove adjusting nut locks and bearing caps. Tag left and right bearing caps for reassembly reference. Using adjusting tool (SST 09524-14010), loosen adjusting nuts and remove differential case from the carrier. Remove bearing races and keep with matching bearing cap.

3) Remove drive pinion and place in holder/bearing remover (SST 09950-20011 and 09956-00010). Remove drive pinion rear bearing. Drive out front and rear pinion shaft bearing cups. Remove side bearings from differential case. Straighten out lock plates on ring gear bolts, index ring gear and case, then remove bolts.

4) Mount differential case and ring gear assembly in vise so ring gear teeth are pointed down. Tap ring gear from case using a brass hammer. Remove pinion gear shaft retaining pin from case. Drive out pinion gear shaft, then remove pinion gears, side gears and thrust washers.

TOYOTA INTEGRAL CARRIER (Cont.)

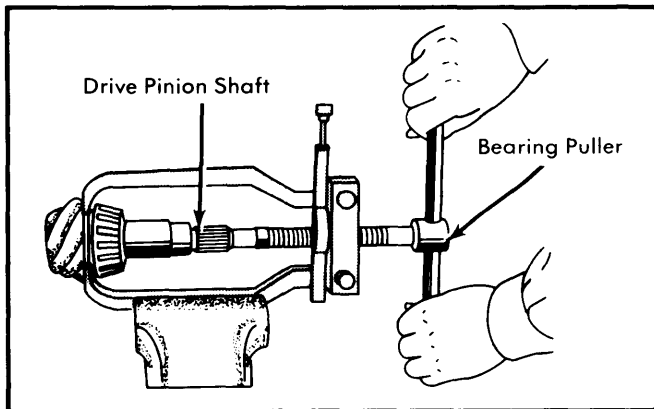

Fig. 5 Removing Drive Pinion Gear Rear Bearing

3) Press differential side bearings onto differential case. Heat ring gear in oil bath to approximately 212°F (100°C), then quickly wipe off gear and install on differential case. Fit bolts and tighten evenly, then bend over lock tabs. Install differential case assembly in differential carrier and measure ring gear runout. If runout exceeds .003" (.07 mm), replace ring gear.

Drive Pinion Depth – 1) Remove differential case from carrier. Install drive pinion bearing cups in carrier. Install pinion shaft rear bearing onto suitable base rod, then install base rod head and bolts. Insert this assembly into carrier from rear. Install front pinion bearing into carrier from front end. Install collar and nut onto front end of base rod.

NOTE – Tighten nut only to extent that driving pinion bearing has no play.

REASSEMBLY & ADJUSTMENT

Case Assembly – 1) Lubricate all components with hypoid gear lubricant. Assemble side gears and pinion gears into differential case. Make sure oil groove, if present, on side gear thrust washer faces toward gear.

2) Check backlash between side gears and pinion gears. If backlash is not .002-.008" (.05-.20 mm), install suitable selective fit thrust washers in equal thicknesses on both sides. Install pinion shaft lock pin and peen over hole.

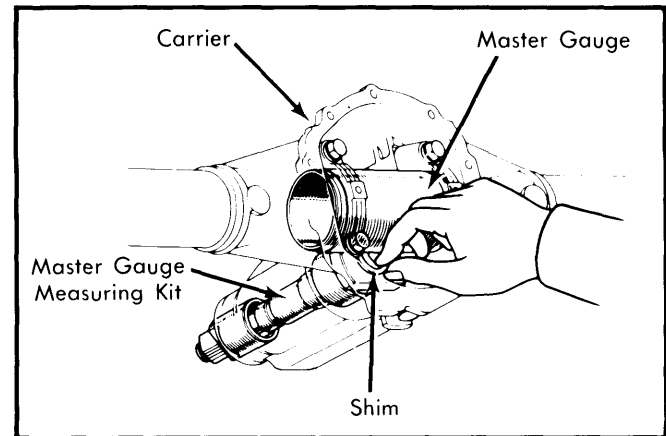

Fig. 8 Measuring Drive Pinion Installed Height

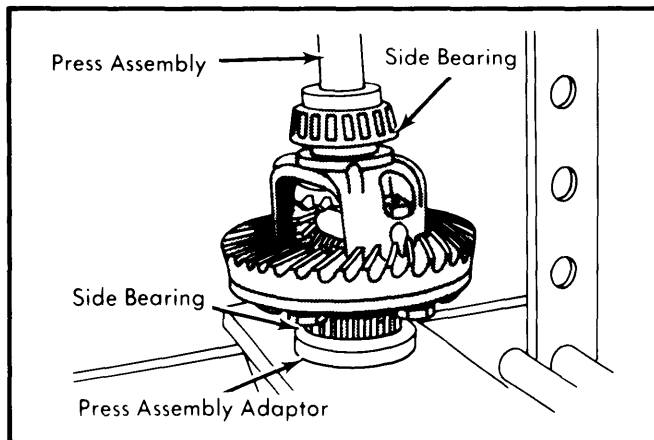

Fig. 6 Installing Side Bearing on Differential Case

2) Install Toyota Master Gauge into differential side bearing bores, then install bearing caps and bolts. Ensure left and right bearing caps are matched with correct bore. Tighten bearing cap bolts to specification. Select a shim that snugly fits between master gauge and base rod head. One shim or none must be used: do not use more. After selecting shim, remove all components of master gauge kit. Press bearing and shim onto drive pinion, if shim has chamfered edge, install that edge toward pinion gear.

Pinion Bearing Preload – 1) Install pinion shaft assembly into carrier. Insert shims (if any) that were removed during disassembly onto pinion shaft. Install NEW bearing spacer, then install front bearing and oil slinger. Press oil seal into carrier .08" (2.0 mm). Install companion flange, washer and NEW nut. Torque pinion flange nut to 80 ft. lbs. (11 mkg).

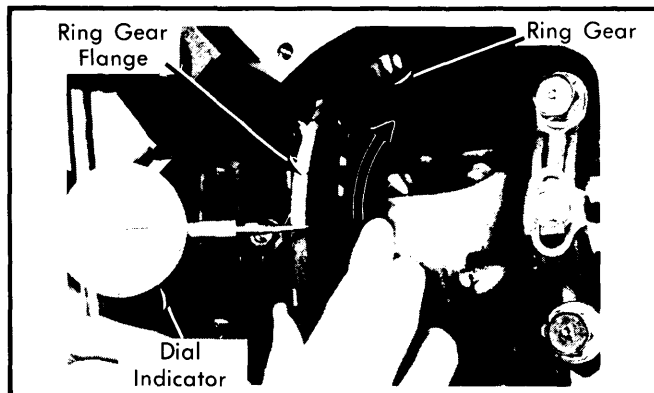

Fig. 7 Measuring Ring Gear Runout

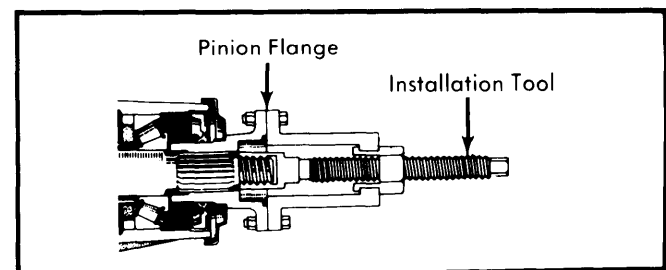

Fig. 9 Installing Pinion Flange

TOYOTA INTEGRAL CARRIER (Cont.)

2) Using an INCH lb. torque wrench, measure pinion bearing preload. If preload is excessive, replace spacer and repeat procedure. If preload is not to specification, tighten nut in small increments and recheck preload each time, until specified preload is reached. If preload is not to specification even after specified torque is reached, loosen nut and repeat procedure.

NOTE — DO NOT exceed 173 ft. lbs. (24 mkg) during preload adjustment.

3) Mount dial indicator to differential carrier and measure companion flange longitudinal and latitudinal deviations. If specifications are exceeded, replace companion flange and recheck.

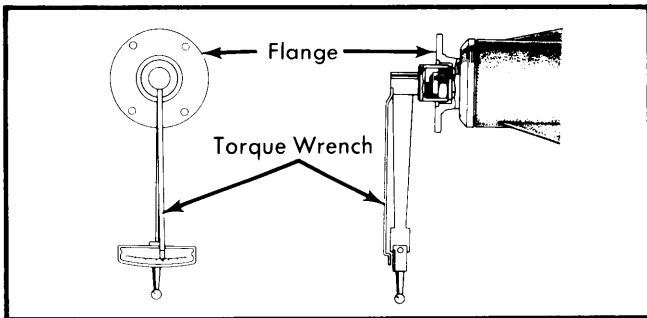

Fig. 10 Measuring Side Bearing Preload

Backlash & Side Bearing Play — 1) Install side bearing adjusting nuts in carrier. Match bearings and bearing cups, then install differential case and bearings into carrier. Install bearing caps and tighten bolts until washers are slightly compressed. Install dial indicator so plunger touches flange side of ring gear. Using bearing adjusting wrench (SST 09524-14011), tighten flange side adjusting nut so ring gear has free play of about .008" (.2 mm).

2) During adjustment procedure, rotate ring gear through several revolutions to seat side bearings. Tighten drive pinion side adjusting nut to the point where free play is eliminated. If tightening nut creates free play, loosen nut. Adjust side bearings for zero preload by tightening drive pinion adjusting nut until it feels hard to turn.

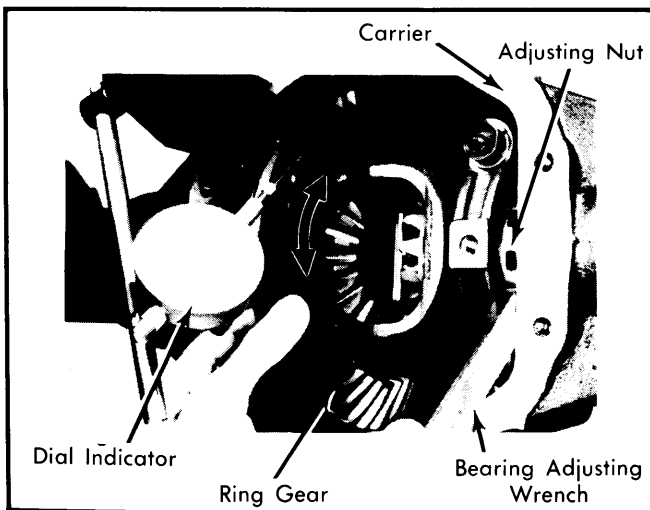

Fig. 11 Measuring Ring Gear Backlash

3) At the point where zero preload is obtained, tighten drive pinion adjusting nut an additional 1-1½ notches to preload side bearings. Mount dial indicator so plunger is perpendicular to ring gear tooth. Measure ring gear backlash. If not within specifications, turn left and right adjusting nuts to shift differential assembly in proper direction. If left side is loosened 1 notch, the right side must be tightened 1 notch to maintain side bearing preload.

4) Tighten side bearing cap bolts. Using an INCH lb. torque wrench, measure total (combined) bearing preload. If preload is not to specifications, repeat adjustment procedures for side bearings and pinion bearings.

Combined (Side & Pinion) Bearing Preload

Application	New INCH lbs. (cmkg)	Used INCH lbs. (cmkg)
All Models	11.3-18.2 (13-21)	6.9-11.3 (8-13)

5) Install bearing adjusting nut locks. Stake drive pinion flange nut. Install inspection cover and tighten bolts. Connect brake line, install lateral control arm and align and install propeller shaft. Install axle shafts, add lubricant to differential carrier and bleed brake system.

TIGHTENING SPECIFICATIONS

Application	Ft. Lbs. (mkg)
Drive Pinion Flange Nut	80-173 (11-24)
Differential Bearing Cap Bolts	51-65 (7-9)
Ring Gear-to-Case Bolts	67-75 (9-10.5)
Axle Shaft Bearing Retainer	44-53 (6-7.4)
Carrier Inspection Cover	15-21 (2-3)
Lateral Control Arm Bolts	
Body-Side Bolt	51-65 (7-9)
Axle-Side Bolt①	26-39 (3.5-5.5)
Adjusting Nut Lock Bolt	8-11 (1-1.6)

① — Corona — 30-55 ft. lbs. (4.1-7.7 mkg).

AXLE SPECIFICATIONS

Application	Specification
Drive Pinion Bearing Preload	
New	8.7-13.9 INCH lbs. (10-16 cmkg)
Used	4.3-6.9 INCH lbs. (5-8 cmkg)
Side-to-Pinion Gear Backlash002-.008" (.05-.20 mm)
Pinion-to-Ring Gear Backlash005-.007" (.13-.18 mm)
Ring Gear Runout003" (.07 mm) Max.
Companion Flange Deviation	
Longitudinal004" (.10 mm) Max.
Latitudinal004" (.10 mm) Max.