

## CHRYSLER CORP. IMPORTS

Arrow  
Arrow Pickup  
Challenger

Colt Wagon  
D50 Pickup  
Sapporo

### DESCRIPTION

Rear axle is of the banjo type, utilizing the removable carrier style differential. Light weight construction joins split tubular housings for each side with center covers welded to axle housing. Final drive is of the hypoid style. Axle shafts are semi-floating type supported with bearings at their respective ends in axle housing. Bearings are fitted to axles with pressure type bearing retainers.

### AXLE RATIO & IDENTIFICATION

Two different differentials are used on passenger vehicles and only one differential is used on pickups. Type "A" differential is used on Arrow with 1600 cc engine (gear ratio 3.909:1 on manual transmission, 3.545:1 on automatic transmission). Type "B" differential is used on Arrow with 2600 cc engine, Challenger, Colt Wagon and Sapporo (gear ratio 3.545:1). Pickups use a modified version of type "B" differential (gear ratio 3.909:1). Side bearing preload is adjusted by shims on type "A" differentials and by side bearing nuts on all other differentials. Pinion bearing preload and pinion depth adjustments are made with shims, while differential side gears are adjusted with spacers on all models.

### REMOVAL & INSTALLATION

#### AXLE SHAFTS & BEARINGS

**Removal (Pickups) – 1** Raise and support rear axle housing so rear wheels clear ground. Remove rear wheel and brake drum. Disconnect hydraulic line from wheel cylinder. Disconnect bearing case from axle housing. Remove back plate, bearing case and axle shaft as an assembly. Use suitable puller set (CT-1003 & C-637) if required, and remove axle shaft.

**2** Remove "O" ring and shims, retain shims for reassembly. Using suitable tool (C-637 with hook), remove and discard inner axle shaft oil seal. Mount back plate, bearing case and axle shaft assembly in a vise. Loosen axle shaft bearing lock washer, then using suitable wrench (MB990785), remove lock nut on rear of back plate. Remove washers and reinstall lock nut on axle shaft approximately 3 turns.

**3** Install suitable puller (MB990787A) to bearing case on rear of back plate. Remove bearing case, then using a hammer and drift, remove bearing outer race. Remove outer bearing oil seal.

**4** Using a dial indicator, inspect axle shaft deflection at points shown in illustration. Replace axle shaft if specifications are exceeded. Inspect wheel hub bolts for tightness and bearing outer retainer for deformation, replace defective parts as necessary.

**Installation – 1** Apply lubricant to outer bearing race and lip of outer oil seal and seat each in bearing case. Slide bearing case and bearing over axle shaft and install inner bearing race and bearing.

**2** Install washer, lock washer and lock nut in that order and tighten lock nut with suitable tool (MB990785). Bend tab on

lock washer into lock nut groove. Install inner oil seal with suitable driver (C-4572).

**NOTE** – If lock washer does not engage lock nut groove, retighten lock nut, without damaging lock washer.

**3** Starting on left side, install .039" (1 mm) shim between axle shaft assembly and axle housing. Tighten all bolts. Insert right axle shaft assembly into axle housing. Using shims of proper size, set clearance between bearing case and axle housing to .002-.008" (.05-.20 mm). Complete installation by reversing removal procedure.

**NOTE** – Clearance must be measured with bearing case seated against axle housing.

Application	Service Limit In. (mm)
Point "A"	
Pickups .....	0-.0024 (0-.06)
All Others .....	0-.0015 (0-.04)
Point "B"	
Pickups .....	0-.039 (0-1)
All Others .....	0-.001 (0-.025)
Point "C" (Passenger Only) .....	0-.039 (0-1)

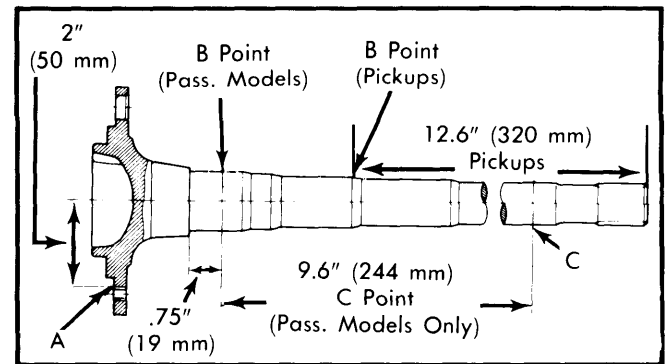


Fig. 1 Measuring Axle Shaft Deflection

**Removal (All Others) – 1** Raise and support rear axle housing so rear wheels clear ground. Remove rear wheel and brake back plate nuts, then disconnect wheel cylinder brake line. Fix suitable puller set (CT-1003 & C-637) to lug studs and work slide hammer until axle shaft is free to be withdrawn. Set brake back plate with parking brake attached out of way. Using suitable tool (C-637 with hook) remove axle shaft oil seal.

**NOTE** – To remove axle shaft on rear disc brake models, disconnect and plug hydraulic line, disconnect parking brake cable at caliper and remove caliper and rotor. Then continue with procedure described for drum brake models.

**2** To remove axle bearing proceed as follows: Grind down bearing retainer at one point until retainer thickness is .04-.06" (1.0-1.5 mm), then chisel ground portion and remove retainer. Using suitable bearing puller or press (CT-1120) remove bearing from axle.

## CHRYSLER CORP. IMPORTS (Cont.)

3) Using a dial indicator, inspect axle shaft deflection at 3 points. See Fig. 7. Replace axle shaft if specifications listed in table are exceeded.

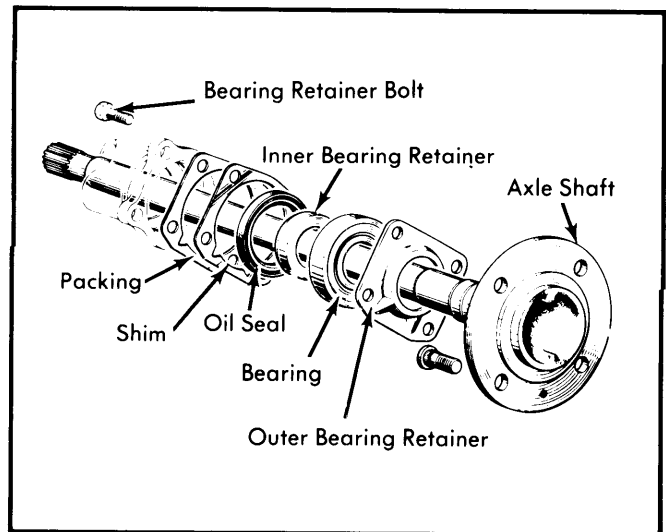
4) Rear axle bearing should be replaced when bearing noise is detected. Inspect wheel hub bolts for tightness and bearing outer retainer for deformation, replace defective parts as necessary.

**Installation** – 1) Fit outer bearing retainer flat side against shaft splined end, then install bearing and inner bearing retainer. Seat bearing retainer with smaller chamfered side directed to the bearing.

**NOTE** – Ensure bearing is completely seated.

2) Lightly coat lips of oil seal with grease and using oil seal installer (DT1007D & C4171), fit axle shaft oil seal in rear axle housing. Using packing and shims in proper sequence, set clearance between bearing and outer bearing retainer to 0.01" (0.25 mm).

3) Carefully insert axle shaft assembly into axle housing using care not to damage seal. Slightly turn axle shaft until splines line up with differential side gears. Align packing oil holes with outer bearing retainer and tighten bearing retainer to axle housing flange. Complete installation by reversing removal procedure. Bleed hydraulic system.

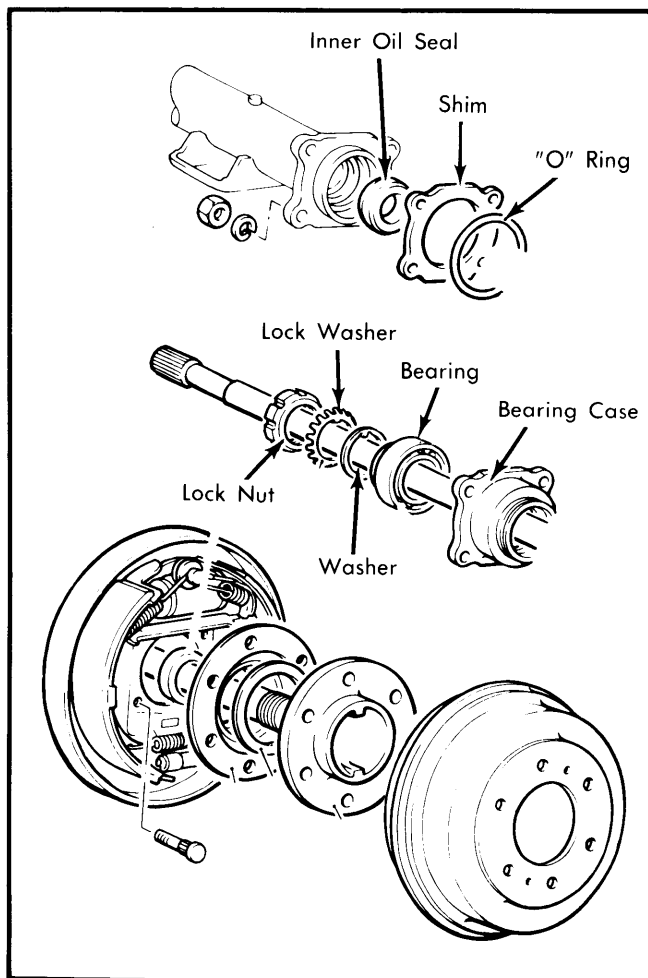


**Fig. 3 Exploded View of Axle Shaft Assembly (Passenger Car Models)**

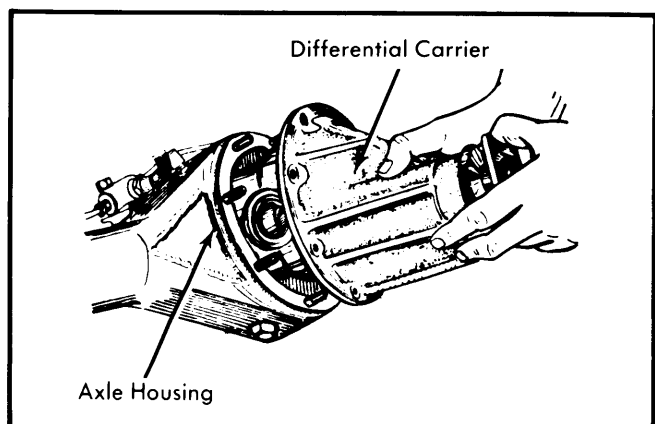
### DIFFERENTIAL CARRIER

**Removal** – Drain oil from rear axle differential housing, then disconnect propeller shaft. Pull out both rear axle shafts approximately 2½". Remove differential gear housing mounting nuts and withdraw the differential gear carrier. It may be necessary to tap outside of housing to break gear carrier loose.

**Installation** – Lightly coat each bearing and gear with oil. Apply sealing compound on packing and axle housing seat, then assemble gear carrier to axle housing with nuts and tighten. Fill differential gear housing with 1.2 quart of suitable multi-purpose gear oil (API GL-5).

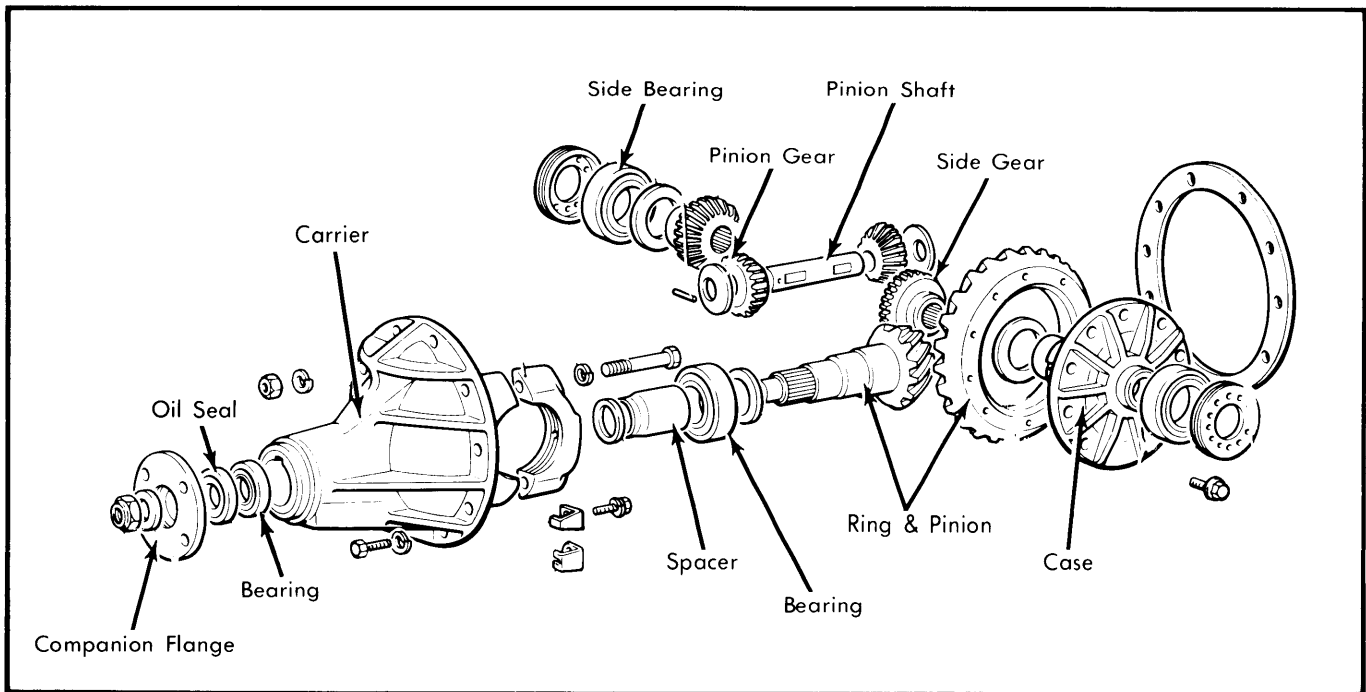


**Fig. 2 Exploded View of Pickup Axle Assembly**



**Fig. 4 Removing Differential Gear Housing**

## CHRYSLER CORP. IMPORTS (Cont.)



**Fig. 5 Exploded View of Chrysler Corp. Import Type "B" Differential Assembly**

### OVERHAUL

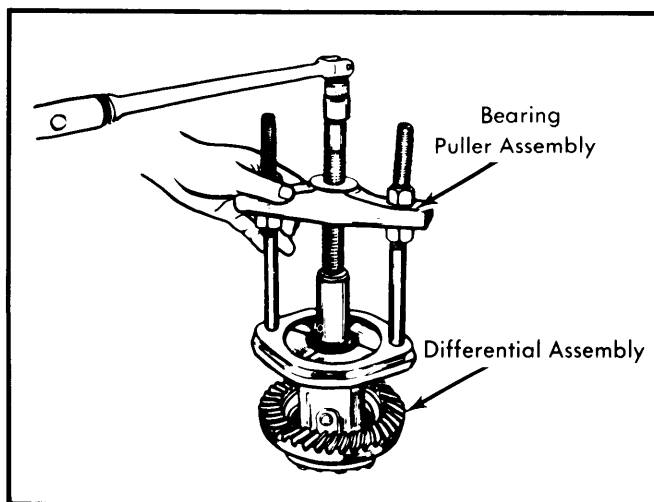
#### DISASSEMBLY

**NOTE** — Remove side bearing lock nuts on Type "B" and pickup differentials with appropriate spanner before beginning disassembly of differential gear assembly.

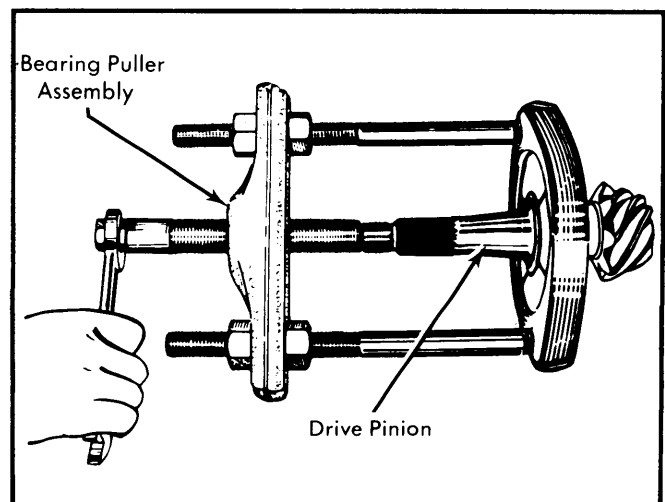
**Differential Gear Assembly** — 1) Remove bearing carrier cap and lever gear case assembly from housing. Using suitable bearing puller tool, pull differential side bearing. Keep right and left bearings and shims in sequence for reassembly.

2) Remove ring gear lock plate tabs and loosen bolts in diagonal sequence, then remove ring gear. Drive out pinion shaft lock pin from ring gear back side using a punch; pull out pinion shaft and pinion. Pinion side gears and spacers are now accessible. Note placement of pinion side gear and spacers and ensure they are reassembled in same position.

**Drive Pinion** — 1) Hold end yoke with suitable tool (C-3281) and remove lock nut, then remove end yoke. Using a wheel puller, force out drive pinion with adjusting shim, rear inner bearing race, spacer and preload adjusting shim.



**Fig. 6 Removing Differential Side Bearings**



**Fig. 7 Removing Rear Drive Pinion Bearing**

## CHRYSLER CORP. IMPORTS (Cont.)

2) With suitable bearing puller, remove rear bearing inner race and at same time, pull off drive pinion adjusting shim. Using suitable drift, remove front drive pinion bearing outer race and oil seal. Repeat same procedure to remove rear bearing outer race.

## INSPECTION

Check differential gears for correct tooth contact and replace gears if wear is excessive. Inspect bearing faces for roughness or score marks and replace bearing assembly, if necessary. Ensure splines of side gears and rear axle shafts fit correctly. Check clearance between pinion gears and pinion shaft, if wear is excessive, replace components.

**NOTE** — To check gear tooth contact using paint impression method, refer to beginning of this section.

## REASSEMBLY &amp; ADJUSTMENT

**Case Assembly** — 1) Install thrust washers (spacers) behind side gears in their original position and assemble pinion and side gears in differential. Insert both pinion gears, with pinion washers attached, so they mesh with side gears. It may be necessary to slightly rotate pinions to achieve desired meshing. Insert drive pinion shaft.

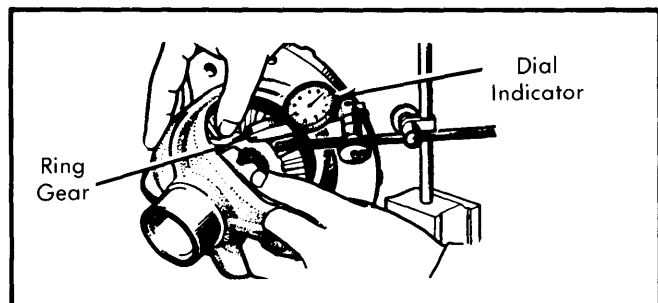


Fig. 8 Checking Differential and Side Gear Backlash

2) Check pinion and side gear backlash as shown in illustration. If backlash is beyond .002-.005" (.05-.127 mm) on pickups or 0-.003" (0-.08 mm) on all other models, adjust by selecting a side gear thrust washer (spacer) of correct size. If backlash is to be adjusted, ensure right and left sides are equally shimmed.

3) Align drive pinion shaft with drive pinion shaft lock pin hole in differential case and drive lock pin into hole from back side of ring gear. Securely stake lock pin in 2 places to prevent movement.

4) Thoroughly clean all dirt from ring gear mounting surface of Type "A" differential case. Install bolts and lock washers. Tighten bolts alternately in a diagonal sequence and bend over lock tabs. Ensure lock washers are in contact with case rib after final torque has been performed.

**NOTE** — On Type "B" and pickup differentials, remove old adhesive and apply Loctite to ring gear mounting bolts. Tighten bolts and do not move vehicle for 1 hour.

**Drive Pinion** — 1) Using a suitable drift and hammer or a press, seat front and rear bearing outer races into gear carrier ensuring that outer races do not cock. Ensure bearing races are completely seated before proceeding. Install shim between drive pinion and rear bearing. Using suitable bearing installer, press bearing onto drive pinion shaft.

2) If drive pinion and bearings are scheduled to be reused, shims should be replaced with new shims of same thickness. In instances where the gear set is to be replaced, install new shims that are the same thickness as the used shims on drive pinion.

**NOTE** — When determining the desired thickness of shim pack, amount of compression (sinkage) of shim pack and wear of the bearing (where old bearing is reused) must be taken into consideration.

**Drive Pinion Depth** — Install drive pinion spacer, front bearing, washer, end yoke and washer in order of removal. Fit pinion shaft retaining nut and slowly tighten nut, continuously checking, until pinion bearing preload is 6-9 INCH lbs. (7-10 cmkg) with oil seal not installed. Place suitable cylinder gauge on inside bearing pedestals of gear carrier housing. Place a block gauge on top end of drive pinion and slip a feeler gauge between the two gauges to obtain the correct pinion height. Select appropriate shim(s) to adjust pinion height to within  $\pm .0012$ " (.03 mm) of measurement taken with block gauge and feeler gauge.

**NOTE** — If pinion depth has to be adjusted by more than .065" (1.65 mm), use two shims. One MUST be .0118" (.30 mm).

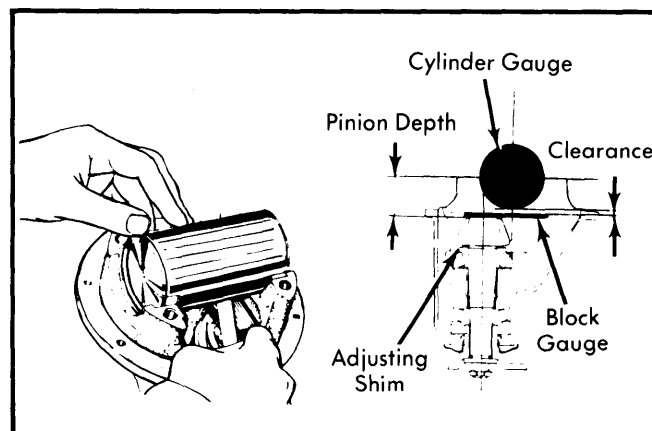


Fig. 9 Measuring Drive Pinion Depth

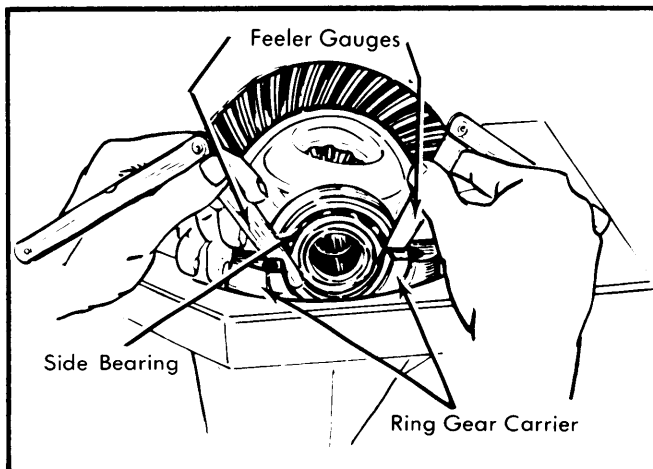
**Pinion Bearing Preload** — This adjustment must be performed after the setting of the drive pinion depth. Remove end yoke and insert the bearing preload adjusting shim between pinion spacer and bearing, then tighten end yoke to 9-11 INCH lbs. (10-13 cmkg) with oil seal installed. In addition to the preload adjusting shims, there are spacers available to provide proper adjustment. After finishing adjustment of drive pinion bearing preload, remove end yoke and apply a thin coat of grease to outer surface of oil seal, then drive seal into position in gear carrier. After greasing oil seal lip, insert end yoke and tighten nut.

## CHRYSLER CORP. IMPORTS (Cont.)

**NOTE** — Side bearing preload on Type "B" and pickup differentials is adjusted by proper tightening of side bearing nut.

**Side Bearing Preload (Type "A")** — Fit each side bearing into differential case, leaving shims out; use suitable tool (CT-1102) for this procedure. Ensure side bearings are completely seated before proceeding. Install differential case assembly on gear carrier, then calculate clearance between side bearing outer race and gear carrier as shown in illustration. After obtaining clearance add .002" (.05 mm) preload figure to each side. Insert shims equally on both sides. Align gear carrier and bearing cap index marks, then tighten cap retaining bolts.

**Side Bearing (Pickup & Type "B")** — After adjusting pinion bearing preload, install side bearing inner races with suitable installer. Install differential carrier in housing and install outer races. Align bearing cap index marks and tighten cap bolts to 7-11 ft. lbs. (1-1.5 mkg). Install bearing nuts. Tighten bearing nuts in clockwise rotation until bearing outer surface is flush with bearing cap outer surface. Back bearing nut out counterclockwise and retighten nut to completely seat bearing. After bearing is completely seated, tighten bearing cap bolts. After tightening bearing caps, turn bearing nuts  $\frac{1}{30}$  turn clockwise ( $\frac{1}{2}$  pitch of 15 bearing nut holes). Check ring gear deflection.



**Fig. 10 Measuring Clearance Between Side Bearing and Gear Carrier (Type "A" Differentials)**

**Ring Gear Deflection (Backside)** — Attach a dial indicator to back side of ring gear and measure deflection. If ring gear has excessive deflection, correct position of the assembly in relation to differential case by shifting position of shims (Type "A") or by tightening/loosening bearing nuts (all others). Recheck measurement. Install lock plate on Type "B" and pickup differentials. Replace ring gear or differential case if runout exceeds .003" (.075 mm) on Type "B" or .002" (.05 mm) on all others.

**Drive Pinion Backlash** — Measure backlash of drive pinion in at least four different spots on ring gear face with drive pinion securely fixed in final position. Set up a dial indicator on ring

gear teeth edges. If measured backlash exceeds .005-.007", correct position of assembly as described for Ring Gear Deflection.

**NOTE** — Check gear tooth contact using paint impression method described at beginning of this section.

**Final Inspection & Assembly** — Lightly coat each gear and bearing before and during reassembly with gear oil. After installing each component, ensure all rotating parts are free to move smoothly. Install differential gear assembly to axle housing after applying sealing agent and tighten gear carrier mounting nuts in diagonal sequence.

### AXLE ASSEMBLY SPECIFICATIONS

Application	Specifications In. (mm)
Bearing-to-Bearing Retainer	
Pickup .....	.002-.008 (.05-.20)
All Others .....	0-.01 (0-.30)
Differential Pinion-to-Pinion Shaft	
Pickup .....	0-.0025 (0-.07)
All Others .....	.001-.003 (.02-.08)
Differential Pinion and Side Gear Backlash	
Pickup .....	.002-.005 (.05-.13)
All Others .....	0-.003 (0-.08)
Drive Pinion and Ring Gear Backlash	.005-.007 (.13-.18)
Ring Gear Runout (Backside)	
Type "B" .....	0-.003 (0-.08)
All Others .....	0-.002 (0-.05)
Drive Pinion Preload	
With Seal .....	9-11 INCH lbs. (10-13 cmkg)
Without Seal .....	6-9 INCH lbs. (7-10 cmkg)

### TIGHTENING SPECIFICATIONS

Application	Ft. Lbs. (mkg)
Outer Bearing Retainer	
Pickup .....	36-43 (5-6)
All Others .....	25-36 (3.5-5)
Ring Gear-to-Differential Case	
Type "A" .....	47-54 (6.5-7.5)
All Others .....	58-65 (8-9)
Final Drive End Yoke (Final Torque)	120-160 (16.5-22)
Differential Carrier Cap	
Pickup .....	40-47 (5.5-6.5)
All Others .....	25-29 (3.5-4)
Differential Gear Carrier	
Assembly-to-Axle Housing .....	18-22 (2.5-3)
Lock Plate (Except Type "A") .....	11-16 (1.5-2)