

HONDA CIVIC

DESCRIPTION

Clutch is single plate dry disc type, using a diaphragm spring to engage pressure plate. Clutch has a mechanical release system consisting of clutch pedal, cable, clutch release lever, and release bearing.

REMOVAL & INSTALLATION

CLUTCH

Removal – 1) Disconnect battery ground at transmission. Release steering lock and put gear shift lever in neutral. Disconnect following engine compartment wiring:

- Positive battery cable at starter.
- Black/White wire from starter solenoid.
- Yellow/Green wire from water temperature sending unit.
- Black/Yellow and yellow wires from ignition timing thermostat.
- Green/Black and yellow wires from back-up light switch.

2) Remove speedometer cable clip and cable but do not disassemble speedometer gear holder. Disconnect clutch cable at release arm and remove transmission side starter mounting bolt. Remove top transmission mounting bolt and forward bolt for rear torque arm bracket.

3) Raise and support vehicle and drain transmission oil. Remove front wheels and stabilizer bar mounting brackets. Disconnect lower support arms at ball joints OR at pivot bolts. Disconnect tie rod end ball joints.

4) Turn right side steering knuckle outward as far as it will go and pry inboard constant velocity (CV) joint out of transmission housing approximately 1/2" to force spring clip out of differential gear splines. Pull axle out the rest of the way and repeat for left side. Disconnect shift lever torque rod from clutch housing. Slide pin retainer back and drive spring pin out with punch, then disconnect shift rod.

5) Place a jack under engine with a wooden block between jack pad and engine, then raise engine enough to take weight off mounts. Remove both front and rear torque rods and rear torque rod brackets. Remove engine damper bracket from transmission and remove rear engine mount with its bracket.

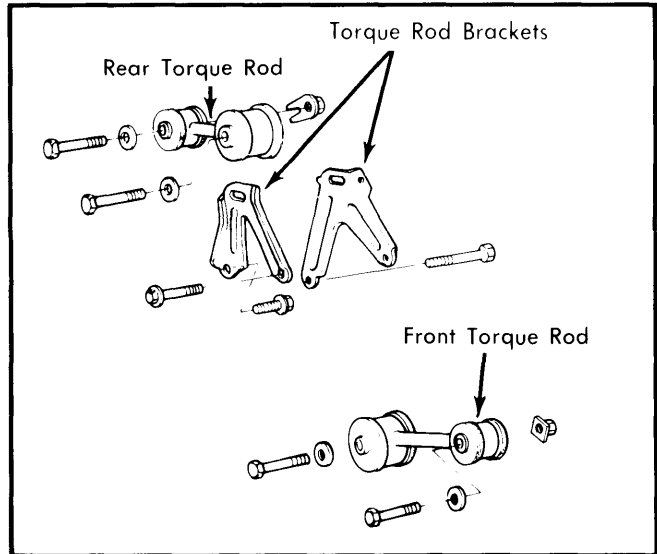

Fig. 2 Torque Rod and Bracket Components

6) Place a 1" x 2" x 4" block of wood between center beam and oil pan, then lower jack so that engine rests on center beam. Remove engine side starter mounting bolt, then remove starter and lower through chassis. Remove 2 remaining transmission mounting bolts. Raise transmission enough with transmission jack to take weight off engine and pull away from engine. Lower transmission clear of engine.

7) Install ring gear holder to keep flywheel from turning. Loosen pressure plate mounting bolts 2-turns at a time in a criss-cross pattern to prevent warping. Remove pressure plate and clutch disc.

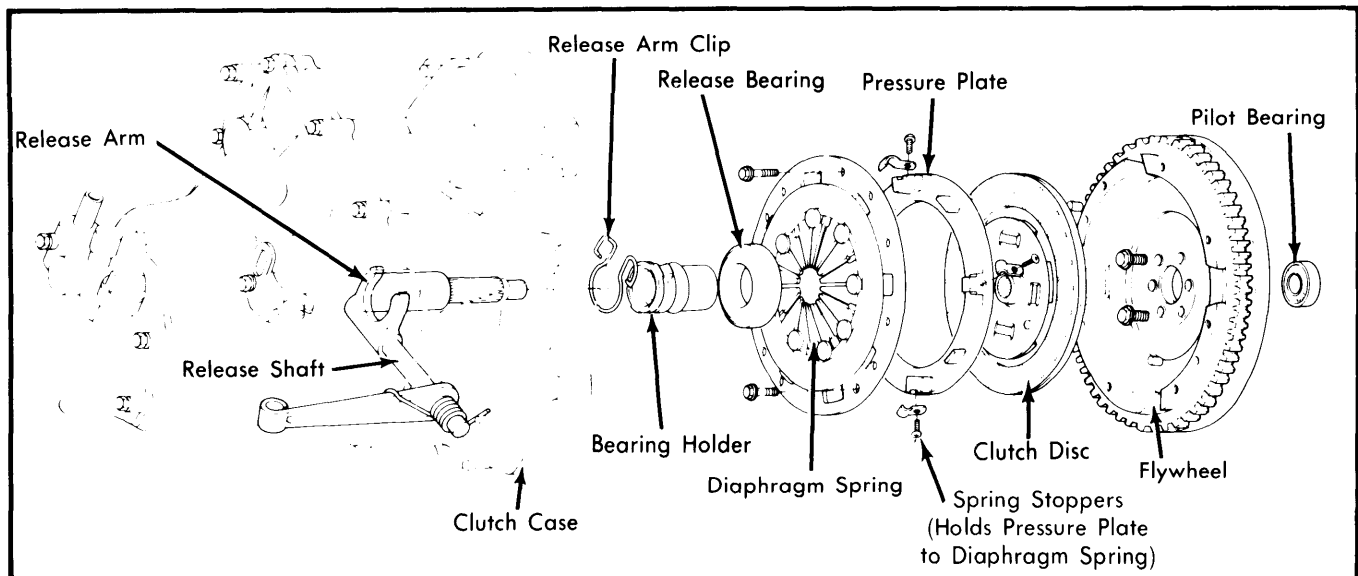

Fig. 1 Exploded View of Clutch Assembly with Bell Housing

Clutches

HONDA CIVIC (Cont.)

Installation — Use a suitable alignment tool and install disc and pressure plate. Tighten bolts 2-turns at a time in a criss-cross pattern. Ensure that the 2 dowel pins are installed in clutch housing and complete installation in reverse order of removal. Ensure that drain plug is tight and refill transmission with SAE 10W-40 oil.

CLUTCH RELEASE BEARING

Removal — Carefully pry ends of release bearing clip out of holes in fork. Slide bearing and holder off shaft sleeve. Bearing and holder may also be removed with release fork by first removing clutch fork shaft.

Installation — Lightly coat all contact surfaces with suitable lubricant and reverse removal procedure. Replace lock plate on shift fork if fork shaft was removed.

NOTE — Do not bend release bearing clips any further than necessary during removal or installation of bearing holder.

ADJUSTMENT

CLUTCH PEDAL

Ensure that pedal return spring holds clutch pedal against stop-pad. Turn adjusting nut in or out to give $\frac{1}{8}$ - $\frac{5}{32}$ " (3-4 mm) free play at release arm. Free play at pedal should be $\frac{3}{8}$ - $1\frac{3}{16}$ " (10-30 mm) and disengagement height should be at least $1\frac{3}{16}$ " (30 mm) from floor. If free play and/or pedal disengagement height exceed these specifications, clutch components may require replacement.

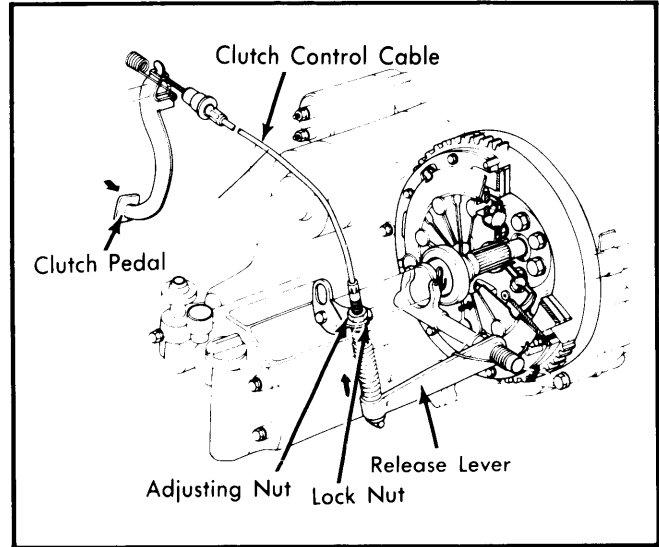

Fig. 3 Clutch Adjustment Point for Civic

TIGHTENING SPECIFICATIONS

Application	Ft. Lbs (mkg)
Clutch-to-Flywheel	9 (1.2)
Flywheel-to-Crankshaft	50 (7.0)
Front and Rear Torque Rod Bolts	54 (7.5)