

FIESTA

Hatchback

DESCRIPTION

The Fiesta clutch consists of a single dry plate clutch disc and a diaphragm spring pressure plate. The disc has 4 torsion springs. The clutch assembly is operated by an automatic self-adjusting device with a release shaft and thrust bearing inside the clutch housing. Fiesta uses two types of gearshift mechanisms, one with a boot on the selector rod, and one with a cranked shifter rod.

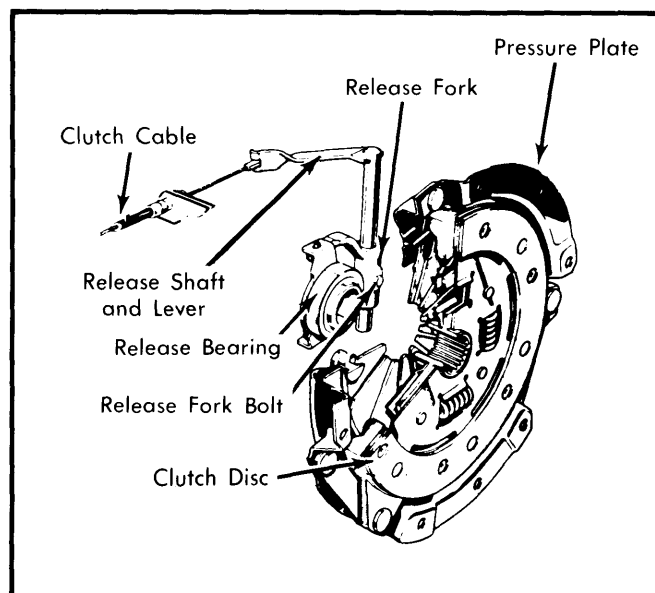

Fig. 1 Clutch Components

REMOVAL & INSTALLATION

CLUTCH ASSEMBLY

Removal – 1) Engage transmission in 4th gear position to ensure correct adjustment after installation. Disconnect battery ground cable. Install suitable engine support bar and clamp. Engine must be supported when transmission is removed.

2) Unscrew speedometer driven gear. Unhook clutch cable from release lever by pulling cable through between lever and support. Remove 4 upper transmission flange bolts. Raise vehicle and drain transmission fluid.

NOTE – Remove plunger retainer and drain fluid out through plunger retainer hole.

3) Remove selector rod spring from selector rod. Loosen selector rod locating bolt. Withdraw selector rod from shift shaft. Remove stabilizer shift assembly from transmission.

4) Unscrew and reposition 2 inner nuts on rubber coupling and engine support. Loosen lock nut on stud and remove stud from transmission housing with Allen wrench.

NOTE – Allow stabilizer and screw to hang on engine support bar.

5) Remove left drive shaft by removing 6 Allen bolts at coupling of inner constant velocity joint and stub shaft. Remove starter and transmission breather tube. Remove 2 lower flange bolts from transmission.

6) Remove 3 bolts from engine mounting. Withdraw transmission to free input shaft from clutch spline. Lower transmission on suitable jack and remove. Remove screws from pressure plate evenly (one turn at a time) and remove clutch assembly from flywheel.

Installation – 1) Apply light coating of grease to splines of drive shaft and differential gear, input shaft splines and thrust bearing carrier bore.

2) Ensure engine adapter plate is properly seated on engine guide bushings. Install transmission. Insert 2 flange bolts and snug. Align engine adapter plate and secure with 2 pins.

3) Mount transmission and clutch adapter plate to engine mounting using 3 new self-locking bolts. Lower engine and tighten bolts. Tighten 2 flange bolts at this time. Install control shaft plunger with spring and retainer.

NOTE – Lightly coat retainer threads with "Omnifit" type lubricant.

4) Install starter and connect cable. Install breather tube so it is suspended freely through hole in side member. Install stabilizer gear to transmission, gently turning Allen screw in as far as stop in transmission housing.

5) Lock screw with nut on rubber coupling of stabilizer. Bring inner nuts on engine mount into contact, and torque outer engine mount nuts.

6) On models with selector rod with boot, place shift shaft and lever in 4th gear position. Pull selector rod down onto shaft and align hole in selector housing with shift lever. Lock in place with a .16" (4 mm) pin.

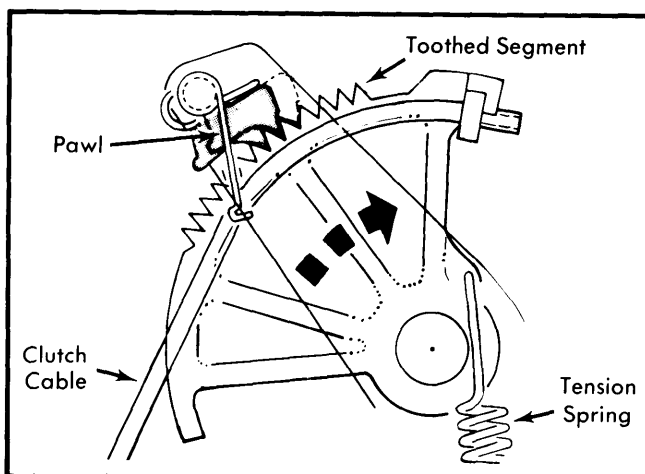

Fig. 2 Automatic Clutch Cable Adjuster

7) Insert suitable spacer between floor pan and selector rod. See Fig. 4 for spacer dimensions. Using a suitable arbor, turn shift shaft clockwise to stop. Tighten selector rod locating bolt.

8) Fit selector rod spring into position on selector rod and frame member. Check operation of shift lever.

FIESTA (Cont.)

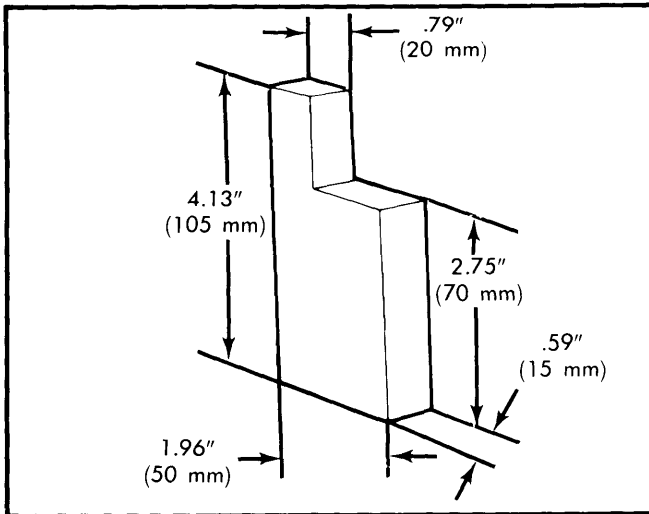

Fig. 3 Selector Rod Spacer Dimensions

9) On models with cranked rod gear shift mechanism place shift shaft and lever in 4th gear position. Loosen selector rod locating bolt and pull shift lever down. Align lever with hole in selector housing and lock with a .16" (4 mm) pin.

10) Using a suitable arbor, rotate shaft clockwise to stop. Tighten selector rod locating bolt. Remove arbor and check shift operation.

NOTE — After installation of the new cranked rod gear shift mechanism, and before any adjustment is made, the retract spring must be installed.

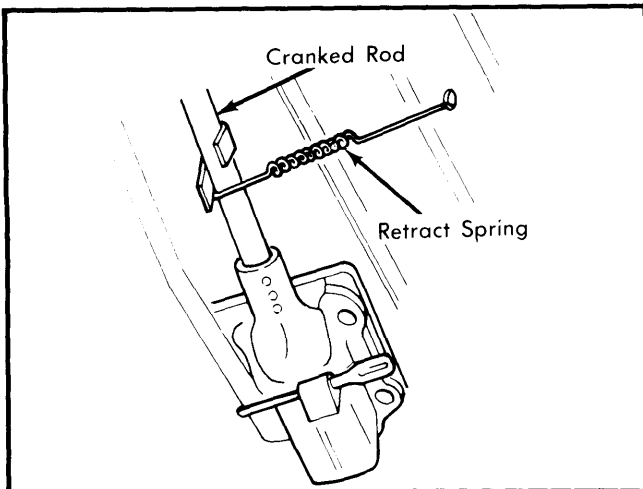

Fig. 4 Cranked Rod Retract Spring Installation

AUTOMATIC CLUTCH CABLE ADJUSTER

Fiesta is equipped with an automatic clutch cable adjuster, and no manual adjustment is required. Automatic adjuster is

located at upper end of clutch pedal. Cable tension is set whenever clutch pedal is depressed as pawl engages with nearest adjusting segment.

CLUTCH CABLE

Removal & Installation — 1) Push cable between lever and support; release and unhook cable from release lever with suitable pliers.

2) Remove lower insulating panel on left side of dash. Bend retaining tabs upward; remove screws and lift off. Pull clutch pedal rearward to release pawl from toothed segment and unhook cable from pedal.

3) Rotate toothed segment forward, unhook cable and allow segment to swivel backward. Pull cable out through recess between pedal and automatic adjuster.

4) To install, reverse removal procedure and note the following: Clutch cable must be routed under pedal stop. After installation, press pedal several times to ensure proper operation of clutch automatic adjuster.

CLUTCH RELEASE FORK & LEVER

Removal — With transmission removed, remove release fork bolt. Separate fork, shaft and lever assembly.

Installation — 1) Prior to installation of shaft and lever assembly, align fork bolt hole in shaft and lever assembly and ensure that the hole is not misaligned with counterbore.

2) Thread fork bolt into position until bolt shank is fully seated in counterbore. If bolt fails to seat in counterbore by hand, replace shaft and lever assembly. Reverse removal procedure and tighten release fork bolt.

TIGHTENING SPECIFICATIONS

Application	Ft. Lbs. (mkg)
Gearbox-to-Engine Flange Bolts	30 (4.1)
Gearbox-to-Engine Brace	
Self-Locking Bolts	65 (9.0)
Small Housing-to-Large Housing	18 (2.5)
Gearshift Lock Cap Nut-to-Housing	22 (3.0)
Gear/Differential Housing	
10.9 Grade Bolt	59 (8.1)
12.9 Grade Bolt	70 (9.6)
Shift Housing-to-Floor Pan	12 (1.7)
Cover-to-Housing	
Sheet Metal Bolt	7.5 (1.0)
Die Cast Bolt	9 (1.2)
Pressure Plate-to-Flywheel	13 (1.8)
Selector Rod Mechanism-to-	
Stabilizer Allen Screw	40 (5.5)