

DATSUN 310

DESCRIPTION

Clutch is a single, dry disc, diaphragm spring type. Main components consist of: clutch cover, pressure plate, and diaphragm spring. Clutch plates are riveted together. A release bearing and fork control clutch engagement and disengagement. Clutch is hydraulic type with a firewall mounted master cylinder and clutch housing mounted slave cylinder.

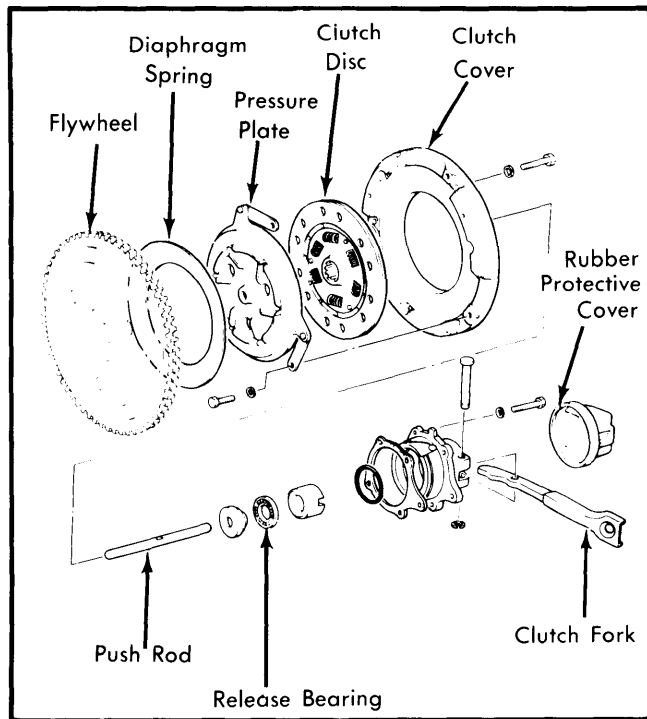

Fig. 1 Exploded View of Clutch Components

REMOVAL & INSTALLATION

CLUTCH ASSEMBLY

NOTE — Clutch assembly can be serviced, removed, or overhauled while transmission and engine remain in vehicle. Also, transmission cannot be removed without removing engine.

Removal — 1) Disconnect battery ground cable, fresh air duct and high tension cable between coil and distributor. Remove fuel filter from bracket. Remove clutch slave cylinder. Remove access hole cover from right wheel well and detach dust cover. Remove clutch release fork retaining clip and pin and remove release fork through access hole.

2) Remove bearing housing attaching bolts and remove primary drive gear assembly through access hole. See Fig. 2. Remove upper clutch housing inspection cover. Rotate ring gear with suitable tool and loosen clutch cover attaching bolts evenly. Lift out clutch cover and disc through inspection cover opening. Remove strap securing pressure plate to clutch cover and remove disc.

NOTE — Keep strap in relative position. It is part of clutch cover dynamic balance.

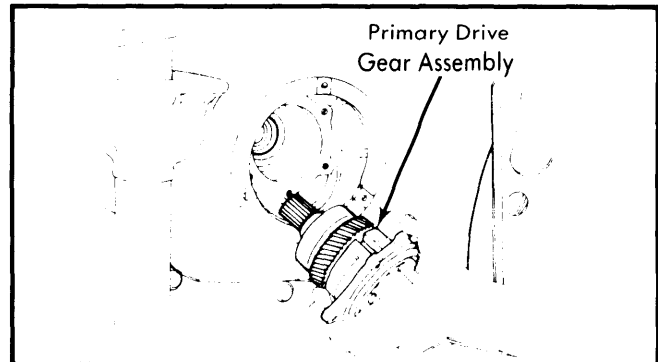

Fig. 2 Removing Primary Drive Gear Assembly

Installation — To install, reverse removal procedure and note the following: Clutch cover and pressure plate must be installed in their original positions to maintain dynamic balance.

RELEASE BEARING

Removal — Separate release lever by removing pivot pin and removing bearing housing. Remove "O" ring and bearing. Hold bearing and rotate outer race, replace if operation is rough or noisy.

Installation — To install, reverse removal procedure and apply multi-purpose grease to sliding parts of release lever.

CLUTCH MASTER CYLINDER

Removal & Installation — Disconnect master cylinder push rod at clevis. Disconnect hydraulic line to slave cylinder. Remove cylinder attaching bolts and remove cylinder. To install, reverse removal procedure and bleed hydraulic system.

SLAVE CYLINDER

Removal & Installation — Disconnect clutch hose from slave cylinder. Remove slave cylinder attaching bolts and remove cylinder. To install, reverse removal procedure and bleed hydraulic system.

OVERHAUL

MASTER CYLINDER

Disassembly — Remove filler cap and drain fluid. Remove dust cover and snap ring. Remove push rod and stopper. Remove supply valve stopper, then take out piston, spring seat and return spring.

Cleaning & Inspection — Clean all parts in clean brake fluid and inspect for wear or damage. If cylinder-to-piston clearance exceeds .006" (.15 mm), replace defective part. Replace piston cup and dust cover during overhaul.

Reassembly — To assemble, coat all parts with brake fluid and reverse disassembly procedure. Bleed system and adjust pedal height.

DATSUN 310 (Cont.)

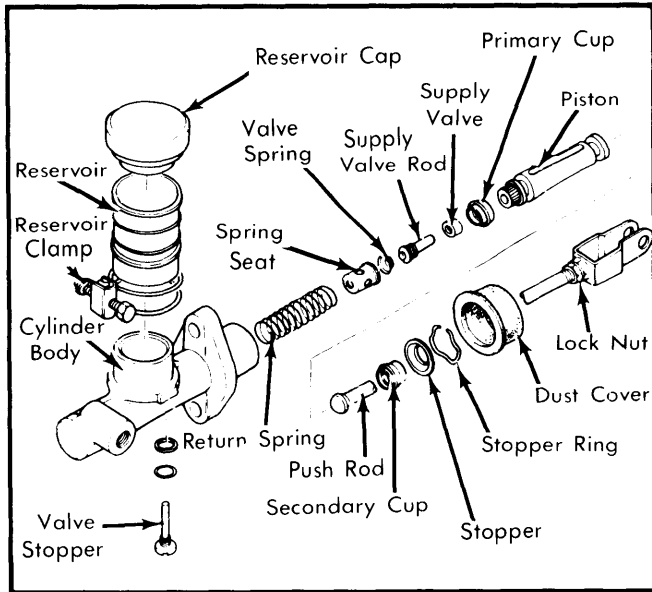

Fig. 3 Exploded View of Master Cylinder

SLAVE CYLINDER

Disassembly — Remove push rod and dust cover. Remove piston and piston cup as an assembly. Remove bleeder screw.

Cleaning & Inspection — Clean all parts in clean brake fluid and inspect for wear or damage. If cylinder-to-piston clearance exceeds .006" (.15 mm), replace defective part. Replace piston cup and dust cover during overhaul.

Reassembly — To assemble, coat all parts with brake fluid and reverse disassembly procedure. Ensure piston cup is properly installed and bleed system.

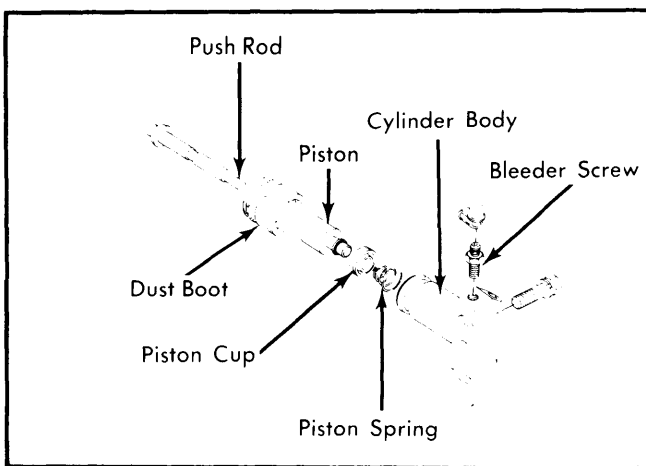

Fig. 4 Exploded View of Clutch Slave Cylinder

NOTE — When pressure plate and clutch disc are replaced, or if any components of release mechanism is replaced, a new push rod may have to be installed.

ADJUSTMENTS

CLUTCH PEDAL HEIGHT & FREE PLAY

Adjust clutch pedal height by turning master cylinder push rod. Correct height is 7.05-7.28" (179-185 mm). Tighten lock nut. Adjust stopper nut so pedal free play is .04-.20" (1-5 mm). Tighten lock nut. See Fig. 5.

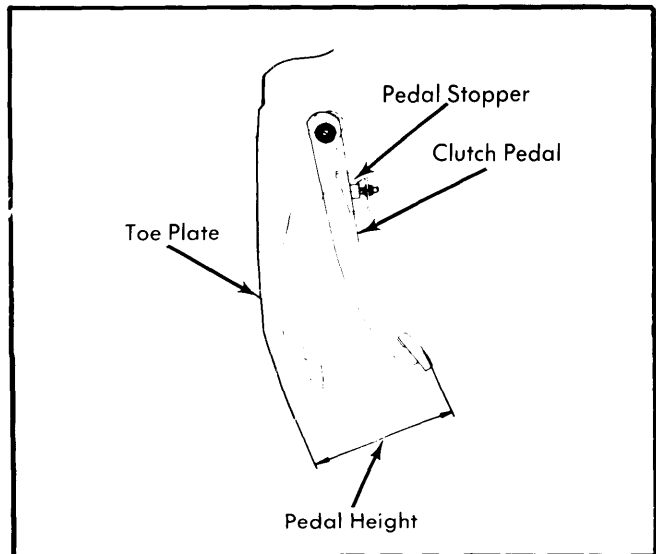

Fig. 5 Pedal Height and Free Play Adjustment

HYDRAULIC SYSTEM BLEEDING

Fit bleeder hose to bleeder valve. Place opposite end into a clear container partially filled with brake fluid. Pump clutch pedal two or three times and hold to floor. Break bleeder valve loose and allow air to vent. Close bleeder screw and allow pedal to return. Repeat procedure until no air bubbles are present in discharged fluid.

TIGHTENING SPECIFICATIONS

Application	Ft. Lbs. (mkg)
Clutch Cover Assy.-to-Flywheel Bolt	5-7 (.7-1.0)
Pressure Plate Strap Bolt	7-9 (1.0-1.3)