

DASHER, JETTA, RABBIT, RABBIT PICKUP, & SCIROCCO

ENGINE CODING

ENGINE IDENTIFICATION

Engine identification number is stamped on left side of engine block near ignition distributor.

Engine Identification	
Application	Code
Dasher	
Man. Trans.	YG
Auto Trans.	YH,YK
Jetta, Rabbit Pickup, & Scirocco	EJ
Rabbit	
Carbureted	FX
Fuel Injected	EJ

ENGINE, CYLINDER HEAD & MANIFOLDS

ENGINE

NOTE — On Jetta, Rabbit, and Scirocco models, engine and transmission must be LOWERED out of vehicle as an assembly.

Removal (Jetta, Rabbit, & Scirocco) — 1) Disconnect battery cables at battery. Loosen fuel filler cap to relieve tank pressure. Drain coolant by removing hose from thermostat flange and disconnect radiator fan motor and thermostitch. Remove radiator with fan and ducts.

2) On air conditioned vehicles, remove air conditioner compressor and tie aside without disconnecting hoses. On all models, disconnect the following electrical connectors: Alternator, thermostitch, oil pressure switch, warm-up regulator, coolant temperature sensor, coil and condenser wires, cold start valve and starter solenoid harness.

3) On carburetor equipped models, remove fuel hose. On fuel injection models, remove injectors. Remove fuel lines for cold start valve and warm-up regulator. On all models disconnect remaining fuel, coolant, emission control and vacuum lines and position out of way. Disconnect and remove accelerator linkage from engine.

NOTE — When disconnecting fuel lines or components, have container available to catch leaking fuel in case system is still under pressure.

4) Disconnect speedometer cable and ground cable from transmission. Detach selector cable and bracket on automatic transmission models. Detach clutch cable and relay shaft lever on manual transmission models. Disconnect starter wires and back up light switch on all models.

5) Remove exhaust flex-pipe nuts or spring clip. Remove starter. Disconnect both drive shafts from drive flanges. Remove horn and place out of way. Remove engine front mount. Remove axle nuts and disconnect lower ball joints from bearing housings, then remove drive shaft while holding strut assembly away from vehicle.

6) Reconnect ball joints so vehicle may be lowered onto wheels. Remove complete rear mount. Remove right front wheel. Attach suitable sling (US 1105) to engine and lift slightly. On manual transmission models, remove relay shaft and gearshift lever rods. On all models, remove bolts holding side mounts to body and lower engine/transmission assembly to dolly. Raise vehicle to clear and remove assembly from beneath car.

Installation — To install, reverse removal procedures using caution to observe all tightening specifications.

NOTE — Mounts must be properly aligned and free of tension before tightening.

Removal (Dasher) — 1) Remove battery and drain crankcase. Remove air cleaner and ducting. Disconnect and plug fuel inlet hose. On manual transmission models, disconnect clutch operating lever, then disengage cable housing from bracket on engine mount.

2) Remove fuse block mounting screws and bend open wiring harness clip. Tie fuel hose, clutch cable and fuse block out of way. Disconnect heater control cable. Remove front engine mount and mount support.

3) Disconnect coil and any electrical components that might interfere with engine removal. If equipped with A/C, remove condensers and compressor and set out of way without disconnecting hoses. Drain coolant then remove radiator and expansion tank.

4) Working under vehicle, remove starter and disconnect exhaust pipe at manifold. On automatic transmission models, remove converter bolts through hole left by starter removal. On all models, remove engine mount nuts and lower engine/transmission bolts.

5) Install support bar under transmission and attach engine hoist. Raise engine until assembly hits steering rack housing and remove upper engine/transmission bolts. Pry engine loose from transmission and remove intermediate plate. Lift and turn engine to left and remove from vehicle. Secure torque converter with strap on automatic transmission models.

Installation — To install, reverse removal procedures, ensuring that aligning dowels between engine/transmission are tight. Torque converter on automatic transmission models must be fully seated with front of pilot approximately 1³/₁₆" (30 mm) below bell housing flange. Check that all mounts are free of strain before tightening.

CYLINDER HEAD & MANIFOLDS

Removal — 1) On cars with carburetors, remove air cleaner and ducting. On fuel injection models, disconnect duct connecting throttle valve housing with mixture control unit. On all models, remove camshaft drive belt and drain engine coolant. If equipped with A.I.R. (California models), disconnect air lines from connections on exhaust manifold.

CAUTION — Never drain coolant while engine is hot. Doing so could cause engine block or cylinder head to warp.

DASHER, JETTA, RABBIT, RABBIT PICKUP, & SCIROCCO (Cont.)

2) Disconnect exhaust pipe. Remove nuts and bolts that hold exhaust manifold and intake manifold (air intake distributor) to head. Remove manifolds. Remove upper alternator bolt and adjusting bracket. Disconnect all coolant hoses and temperature gauge wire. Remove spark plugs.

3) Remove valve cover. Remove head bolts in reverse order of tightening sequence. If head is stuck, insert a block of wood in each outboard exhaust port and pry free.

Installation — To install, reverse removal procedure and note the following: Make sure head gasket is positioned with "OBEN" mark facing up. Tighten head bolts in sequence and steps shown.

Cylinder Head Tightening Steps

Application	Ft. Lbs. (mkg)
Step One	29 (4.0)
Step Two	43 (6.0)
Step Three	54 (7.5) Plus ¼ Turn

NOTE — Polygon (12 point) socket head bolts are set to final torque while cold and do not need to be retorqued when hot. Tighten in sequence to 54 ft. lbs. (7.5 mkg) plus an additional ¼ turn.

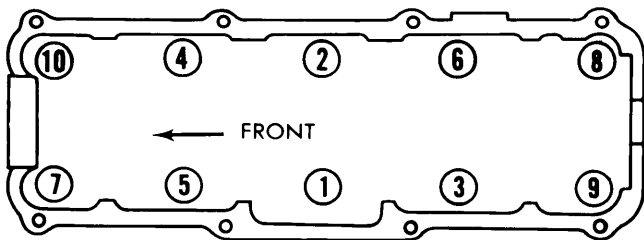

Fig. 1 Cylinder Head Tightening Sequence (Loosen in Reverse Order)

CAMSHAFT

TIMING BELT

NOTE — Sprockets DO NOT have to be removed to replace camshaft drive belt.

Removal — On cars with carburetors, remove air cleaner and related ducting. Remove alternator belt, water pump pulley, and upper and lower drive belt covers. If equipped, remove air conditioning compressor drive belt and air injection pump belt. Loosen belt tensioner, and work belt off sprockets toward front of engine.

Installation — 1) Rotate camshaft sprocket until index punch mark on camshaft sprocket is lined up with top surface of valve cover mounting flange on spark plug side of head. Rotate crankshaft and intermediate shaft until index punch mark on intermediate shaft sprocket aligns with "V" notch on crankshaft pulley.

2) Use care not to move any sprocket. Fit belt on bottom first and then at top so there is no slack between sprockets. Tighten tensioner so belt can just be twisted 90° halfway between camshaft and intermediate sprockets. Tighten adjuster locknut and reverse removal procedure for remaining components.

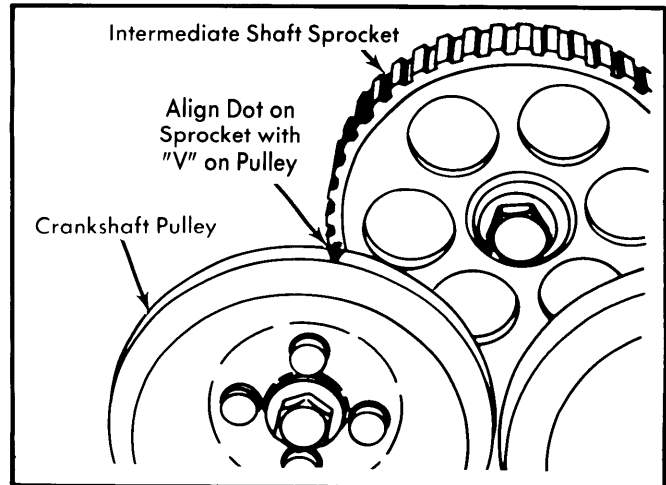

Fig. 2 Crankshaft and Intermediate Shaft Index Marks Aligned with Notch on Crankshaft Pulley

CAMSHAFT

Removal — 1) Remove camshaft cover. Loosen and remove bearing caps in following sequence: 5, 1, and 3, then loosen bearing caps 2 and 4 diagonally. Bearing caps are numbered front to rear.

2) Check camshaft end play. Remove camshaft and lift out cam followers. Install camshaft using only bearing caps 1 and 5. Fit dial indicator so tip of gauge touches front of camshaft. Pry camshaft back and forth. Reading should not exceed .006" (.15 mm). If end play is beyond limits, replace either camshaft or cylinder head.

3) Check camshaft runout. Fit dial indicator so gauge pin is against camshaft center journal. Turn camshaft and record runout range. Runout must not exceed .0004" (.01 mm). Replace camshaft as necessary.

4) Inspect camshaft lobes for wear. Worn lobes usually indicate lack of lubrication. Check engine oiling passages to make sure they are not restricted. Replace worn camshafts and worn discs.

5) Inspect cam followers for signs of seizure or lack of lubrication. If any aluminum particles from head are found on cam followers, replace followers. Cylinder head must be replaced if any follower bores are worn or excessively rough.

Installation — Lightly lube cam follower bores, then fit followers in their original bores. Install adjusting discs. Place camshaft on cylinder head. Loosely attach No. 2 and No. 4 bearing caps. Gradually tighten caps. Fit No. 5 and No. 3 bearing caps. Install new oil seal in front of camshaft. Install No. 1 bearing cap. Make sure all caps are torqued to proper specifications.

VALVE TIMING

With timing belt removed as previously described, rotate crankshaft and intermediate shaft until index mark (punch mark) on intermediate shaft is positioned in "V" notch on

DASHER, JETTA, RABBIT, RABBIT PICKUP, & SCIROCCO (Cont.)

crankshaft pulley. See Fig. 2. This is firing point of No. 1 cylinder. Next, turn camshaft until timing mark on rear of camshaft sprocket is in line with top of cylinder head cover flange. See Fig. 3. Replace timing belt.

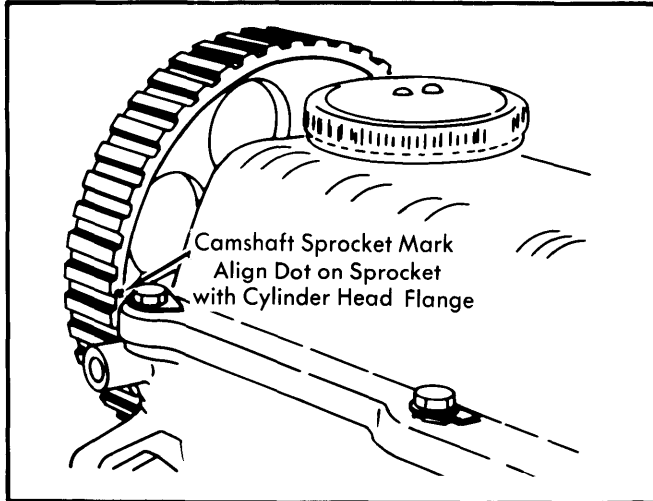

Fig 3 Index Mark on Camshaft Sprocket Aligned with Cylinder Head Flange

VALVES

VALVE ARRANGEMENT

E-I-E-I-E-I-E (front to rear).

VALVE GUIDE SERVICING

1) Clean valve guides before making measurements. To measure guide, attach a suitable mounting device with a dial gauge (VW689/1) to mounting surface of cylinder head. Insert a new valve until end of stem is flush with end of valve guide.

2) Rock valve head against dial indicator and check amount of rock recorded. Maximum allowable rock is .039" (1 mm) for intake valves and .051" (1.3 mm) for exhaust valves. Proper valve guide diameter is .315"-.316" (8.01-8.04 mm).

3) Use a press and suitable adaptor (10-206) to remove and install valve guides. To remove guides, press out from combustion chamber side of head.

4) Coat new valve guides with engine oil. Press new guides into cold head from camshaft side. Make sure shoulder of guide meets firmly with top of cylinder head. Ream guides to uniform inside diameter.

CAUTION — Do not use more than 1 ton pressure once guide shoulder is seated or shoulder may break.

VALVE SPRINGS

NOTE — Although normal maintenance on valve system is performed with head removed, it is possible to replace stem seals, keepers, retainers or broken springs with cylinder head installed.

Removal (Head Installed) — With camshaft and tappets removed, turn crankshaft until piston of cylinder you are working on is at BDC. Apply steady air pressure of at least 85 psi through spark plug hole adapter to keep valves seated. Compress spring with suitable tool (VW 541) and remove valve keepers. Remove and replace damaged or worn parts.

Removal (Head Removed) — With camshaft and tappets removed, use suitable compressor (VW 541) to depress retainer and remove keepers. Take out retainer and springs.

Installation — Check springs on spring tester and inspect for cracks or distortion. Reverse removal procedure and note the following: Lower edge of valve spring retainer should be chamfered to prevent valve stem scoring. If necessary, grind a chamfer using stone or other suitable tool. When installing the springs, make sure closely spaced coils of outer springs are against spring seats.

VALVE STEM OIL SEALS

With tappet, adjuster pad, keepers, springs, and spring seats removed, extract valve stem oil seal. When installing new seal, first position protective plastic sleeve on valve stem, lubricate seal, and use a suitable mandrel (10-204) to push seal onto valve guide.

VALVE CLEARANCE ADJUSTMENT

1) Adjust valves with engine at normal operating temperature. Clearance adjustments are to be checked and made according to firing order. Using a wrench on the crankshaft pulley bolt, turn clockwise to bring No. 1 piston to TDC (cam lobes pointing up). Determine valve clearance by inserting a feeler gauge between cam lobe heel and adjusting disc.

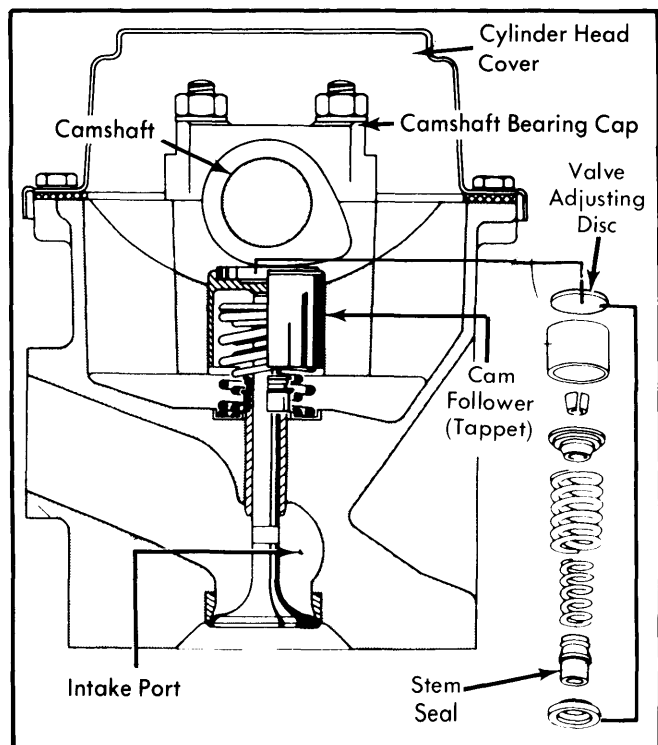

Fig. 4 Assembled View of Valve and Camshaft

DASHER, JETTA, RABBIT, RABBIT PICKUP, & SCIROCCO (Cont.)

2) Rotate crankshaft pulley 180° at a time, and check cylinders No. 3, No. 4 and No. 2, consecutively. If necessary, adjust to specifications by installing thicker or thinner adjusting discs. Discs are available in 26 different thicknesses in increments of .0019" (.05 mm). Disc thickness is stamped on the bottom, and ranges from .1181" (3.0 mm) to .1673" (4.25 mm). To install, press cam follower down with follower depressing tool (VW 546). Remove old disc with special pliers (VW 208), and insert new disc with stamped thickness marking toward cam follower.

Valve Clearance Specifications

Application	In. (mm)
Intake	
Hot008-.012 (.20-.30)
Cold006-.010 (.15-.25)
Exhaust	
Hot016-.020 (.40-.50)
Cold014-.018 (.35-.45)

NOTE — Cold settings are given for reference, as initial settings to be used during cylinder head rework. Final adjustments are made at normal operating temperature, and should be rechecked after approximately 1000 miles of operation.

PISTONS, PINS & RINGS

OIL PAN

Removal — On Rabbit and Scirocco, drain oil, remove bolts and remove oil pan. On Dasher, support engine from above with support bar and threaded rod. Remove nuts holding engine mounts on subframe and bolts holding subframe to body. Pull subframe downward to separate engine mounts and body. Drain oil, remove mounting bolts and remove oil pan.

Installation — To install, reverse removal procedure. Make sure gasket surfaces are clean before installing new gaskets.

PISTON & ROD ASSEMBLY

NOTE — Piston and rod assemblies can be removed with engine in vehicle. Manufacturer recommends engine removal for extensive overhaul work.

Removal — Mark cylinder number on crown of each piston. If necessary, mark arrows pointing toward front of block on piston crowns. Remove rod cap bolts and force piston out top of cylinder. Use wooden hammer handle for this operation. Mark connecting rods and bearing caps for proper reinstallation.

NOTE — If a ridge at top of cylinder prevents piston removal, use a ridge reamer to cut down the ridge. DO NOT force piston out of cylinder.

Installation — Turn crankshaft so No. 1 journal is at BDC. Install piston connecting rod assembly until ring compressor contacts block. Use a wood handle to push piston into cylinder. Install No. 4 Piston and rod assembly. Ensure tabs on bearing halves engage notch in rod and cap. Install and tighten caps on rods 1 and 4. Turn crankshaft 180° and install No. 2 and 3 rod assemblies and rod caps.

PISTON PINS

Removal — Use needle-nosed pliers to remove pin circlips. Press out pin and remove piston from rod. For installation purposes, note direction piston is fitted to rod.

Installation — 1) Check pin fit in each piston. Piston pin must be a thumb-push fit in piston. If correct fit is not obtained, replace both pin and piston.

2) Check pin fit in connecting rod. Wear limit is .0015" (.04 mm). Rebush connecting rod and hone bushing to obtain correct clearance.

FITTING PISTONS

1) Measure cylinder at 3 points: 3/8" (10 mm) from top and bottom, and at center of bore. Take measurements in line with, and at 90° to thrust face. Maximum cylinder taper or out-of-round is .0016" (.04 mm) beyond standard dimensions. If excessive, cylinder reboring and oversize pistons are necessary.

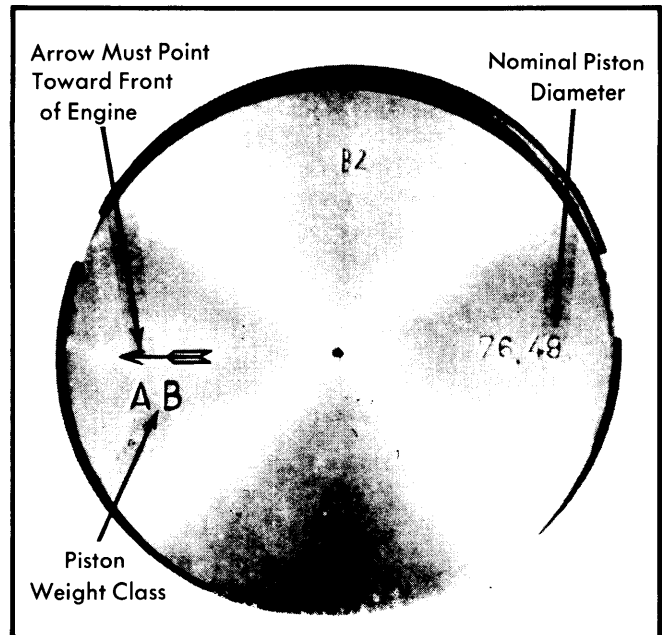

Fig. 5 Codes Stamped on Piston Head

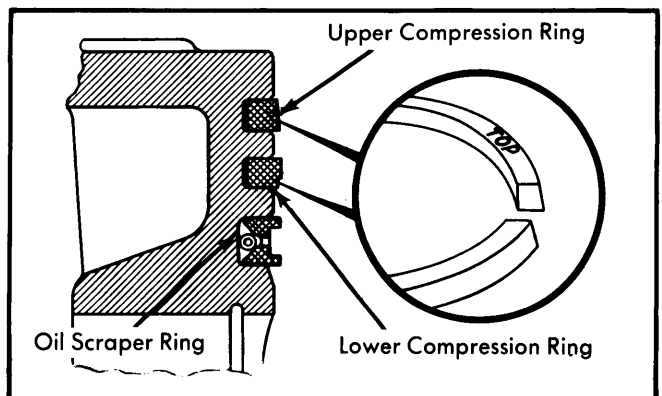

Fig. 6 Piston Ring Installation — Word TOP Must Face Piston Crown

2) Measure pistons at .63" (16 mm) from bottom of piston skirt (measuring 90° to pin bore). Combining this measure-

DASHER, JETTA, RABBIT, RABBIT PICKUP, & SCIROCCO (Cont.)

ment with measurement of corresponding cylinder bore, note piston-to-cylinder clearance. If this exceeds .0028" (.07 mm), oversize pistons must be installed.

3) Place piston rings squarely in top of cylinder bore (above ring ridge) and measure end gap. Measure ring side clearance. Install rings on piston with end gaps 120° offset to each other (start with oil ring gap directly to the rear). Ensure stamp mark "TOP" on rings is facing upward.

CRANKSHAFT MAIN & CONNECTING ROD BEARINGS

MAIN & CONNECTING ROD BEARINGS

1) Push crankshaft toward one end and measure crankshaft end play at No. 3 (thrust) bearing. Main bearing caps are stamped "1" to "5" (front to rear), and must be returned to original positions upon reassembly. Measure end play (side play) of connecting rods. Remove all bearing caps and check bearing clearance using Plastigage method.

2) Measure crankshaft journals with a micrometer to determine journal out-of-round and taper. The maximum allowable wear is .0012" (.03 mm). Install main bearing inserts with oil groove in the engine block, making sure anti-rotation tabs engage in saddle notches. Lubricate new bearings, place crankshaft in block, and install lower main shells and caps in proper order.

Crankshaft Journal Diameters

Size	Main Bearing In. (mm)	Rod Bearing In. (mm)
Standard	2.124 (53.95)	1.809 (45.95)
1st US	2.114 (53.70)	1.799 (45.70)
2nd US	2.104 (53.45)	1.789 (45.45)
3rd US	2.094 (53.20)	1.779 (45.20)

REAR MAIN BEARING OIL SEAL

NOTE — Rear main bearing oil seal may be replaced with engine in vehicle. Transmission and flywheel must be removed.

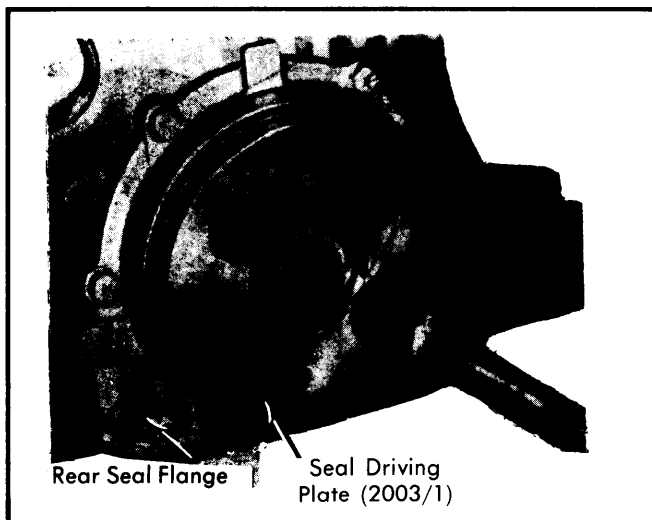

Fig. 7 Using Special Tool to Install Rear Main Oil Seal

Insert a large screwdriver between crankshaft flywheel flange and inside lip of oil seal. Pry out old seal. Install seal guide sleeve (2003/2A or equivalent) over crankshaft flange. Start new seal over guide sleeve, and into recess in seal carrier. Remove guide sleeve and bolt seal driving plate (2003/1 or equivalent) to flywheel mounting flange. Tighten bolts evenly to bring seal flush with carrier.

FRONT MAIN BEARING OIL SEAL AND INTERMEDIATE SHAFT OIL SEAL

Remove camshaft belt. Remove crankshaft sprocket. Pry seal from seal carrier, being careful not to damage carrier. Use removing tool (10-219 or equivalent) to remove seal. See Fig. 8. Using installing tool (10-203 or equivalent), press in new seal until flush with seal carrier. If tool 10-203 was used, remove it and using aluminum part of tool, press seal in until recessed .080" (2.0 mm) in seal carrier.

NOTE — Same procedure applies to intermediate shaft oil seal except: Remove intermediate shaft sprocket. Only press new seal in until flush with seal carrier.

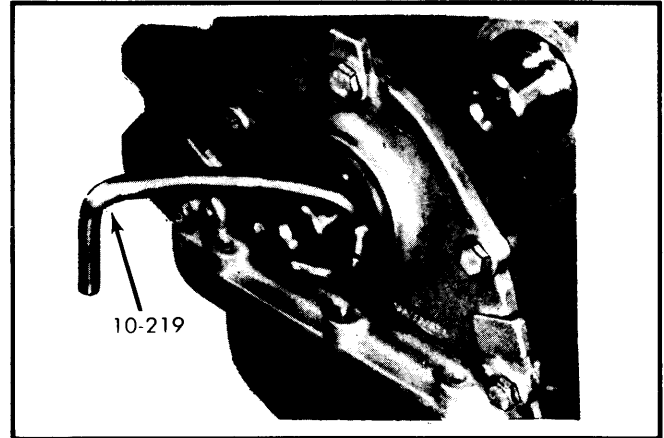

Fig. 8 Using Special Tool to Remove Front Oil Seal

ENGINE OILING

Crankcase Capacity — On Rabbit and Scirocco models, 3.7 quarts with filter change. On Dasher models, 3.2 quarts with filter change.

Oil Filter — Replaceable spin-on type.

Normal Oil Pressure — Minimum of 28 psi (1.97 kg/cm²) with engine at normal operating temperature.

ENGINE OILING SYSTEM

Oiling system is a pressure feed type. A gear oil pump lifts oil from pan and pressure feeds it to crankshaft journals, camshaft bearings, and intermediate shaft. Other parts of system receive oil mist or splash for lubrication.

OIL PUMP

Removal — 1) With oil pan removed (see OIL PAN in this article), remove pump mounting bolts. Remove oil pump, leaving pickup tube attached.

2) Separate pickup tube from pump. Check oil pump gear backlash. Clearance should be between .002-.008" (.05-.20 mm). If specification is exceeded, replace gears or pump.

Volkswagen Engines

DASHER, JETTA, RABBIT, RABBIT PICKUP, & SCIROCCO (Cont.)

3) Measure oil pump gear end play. If end play exceeds .006" (.15 mm), replace pump.

Installation — To install, reverse removal procedure. Make sure all mating surfaces are clean before installing gaskets. Oil pump drive shaft must align with distributor drive gear.

ENGINE COOLING

Cooling System Capacity	
Application	Capacity (Qts.)
Jetta, Rabbit, Rabbit Pickup & Scirocco	4.9
Dasher	
With Expansion Tank	6.9
Without Expansion Tank	6.4

Thermostat — Begins to open at 185°F (85°C), and is fully open at 221°F (105°C).

WATER PUMP

NOTE — The front portion of water pump (shaft, seals, bearing, and housing) can be replaced separately. To do this camshaft drive belt and sprockets must be removed. To avoid removing drive belt, remove water pump as an assembly.

Removal — Drain coolant with engine cool. Remove alternator belt and alternator. Remove air injection pump belt (if equipped). Disconnect hoses from water pump and remove bolt holding camshaft drive belt cover to water pump. Remove water pump bolts and pump assembly.

Installation — To install, reverse removal procedure and make sure to use new "O" ring in recess in pump mounting flange.

NOTE — Do not use sealer between water pump mounting flange and engine block.

ENGINE SPECIFICATIONS

GENERAL SPECIFICATIONS										
Year	Displ.		Carburetor	HP at RPM ^①	Torque (Ft. Lbs. at RPM)	Compr. Ratio	Bore		Stroke	
	cu. ins.	cc					in.	mm	in.	mm
1980 Rabbit w/Carb. w/CIS ^① Scirocco & Dasher	88.9	1457	34 PICT-5 Fuel Inj.	62@5400	76.6@3000	8.0:1	3.13	79.5	2.89	73.4
	97.0	1588		76@5500	82.7@3200					
	97.0	1588	Fuel Inj.	76@5500	82.7@3200	8.2:1	3.13	79.5	3.15	80.0

① — Includes Jetta & Rabbit Pickup.

VALVES							
Engine & Valve	Head Diam. In. (mm)	Face Angle	Seat Angle	Seat Width In. (mm)	Stem Diameter In. (mm)	Stem Clearance In. (mm)	Valve Lift In. (mm)
1457 cc & 1588 cc Intake	1.338 (33.9)	45°	45°	.079 (2.0)	.314 (7.98)	.001-.002 (.03-.05)
	1.220 (31.0)	45°	45°	.095 (2.4)	.313 (7.95)	.002-.003 (.05-.07)

PISTONS, PINS, RINGS						
Engine	PISTONS		PINS		RINGS	
	Clearance In. (mm) ^①	Piston Fit In. (mm)	Rod Fit In. (mm) ^②	Rings	End Gap In. (mm) ^③	Side Clearance In. (mm) ^④
1457 cc & 1588 cc	.0012 (.03)	Push Fit	.0004-.0008 (.01-.02)	Comp.	.012-.018 (.30-.45)	.0008-.002 (.02-.05)
				Oil	.010-.016 (.25-.40)	.0008-.002 (.02-.05)

① — Wear limit .027" (.07 mm). ② — Wear limit .010" (.25 mm). ③ — Wear limit .039" (1 mm).

④ — Wear limit .006" (.15 mm).

Volkswagen Engines

DASHER, JETTA, RABBIT, RABBIT PICKUP, & SCIROCCO (Cont.)

ENGINE SPECIFICATIONS (Cont.)

CRANKSHAFT MAIN & CONNECTING ROD BEARINGS							
Engine	MAIN BEARINGS				CONNECTING ROD BEARINGS		
	Journal Diam. In. (mm)	Clearance In. (mm)①	Thrust Bearing	Crankshaft End Play In. (mm)②	Journal Diam. In. (mm)	Clearance In. (mm)③	Side Play In. (mm)④
1457 cc & 1588 cc	2.124 (53.95)	.001-.003 (.025-.076)	No. 3	.003-.007 (.07-.17)	1.809 (45.95)	.0011-.0033 (.028-.088)	.010 (.25)

① - Wear limit .007" (.17 mm). ② - Wear limit .015" (.37 mm). ③ - Wear limit .0047" (.12 mm).
④ - Wear limit indicated.

CAMSHAFT			
Engine	Journal Diam. In. (mm)	Clearance In. (mm)①	Lobe Lift In. (mm)
1457 cc & 1588 cc0008-.002 (.02-.05)

① - End play .006" (.15 mm)

VALVE SPRINGS			
Engine	Free Length In. (mm)	PRESSURE Lbs. @ In. (kg @ mm)	
		Valve Closed	Valve Open
1457 cc & 1588 cc Inner	46-51@.719 (21-23@18.3)
Outer	96-106@.916 (43.5-48@22.3)

TIGHTENING SPECIFICATIONS	
Application	Ft. Lbs. (mkg)
Timing Belt Tensioner Lock Nut	33 (4.5)
Intermediate Sprocket Bolt	58 (8.0)
Crankshaft Sprocket Bolt	58 (8.0)
Water Pump Pulley Bolts	14 (2.0)
Crankshaft Pulley Bolts	14 (2.0)
Main Bearing Cap Bolts	47 (6.5)
Drive Plate-to-Crankshaft Bolts	54 (7.5)
Connecting Rod Cap Bolts	33 (4.5)
Camshaft Sprocket Bolt	58 (8.0)
Camshaft Bearing Cap Bolts	14 (2.0)
Cylinder Head Bolts	54 (7.5) plus 1/4 turn
Ball Joints	36 (5.0)
Axle Nuts	174 (24.0)
Manifolds-to-Cylinder Head Bolts	18 (2.5)
Water Pump Bolts	14 (2.0)
Oil Pan Bolts	14 (2.0)